

Screwdriver Sets

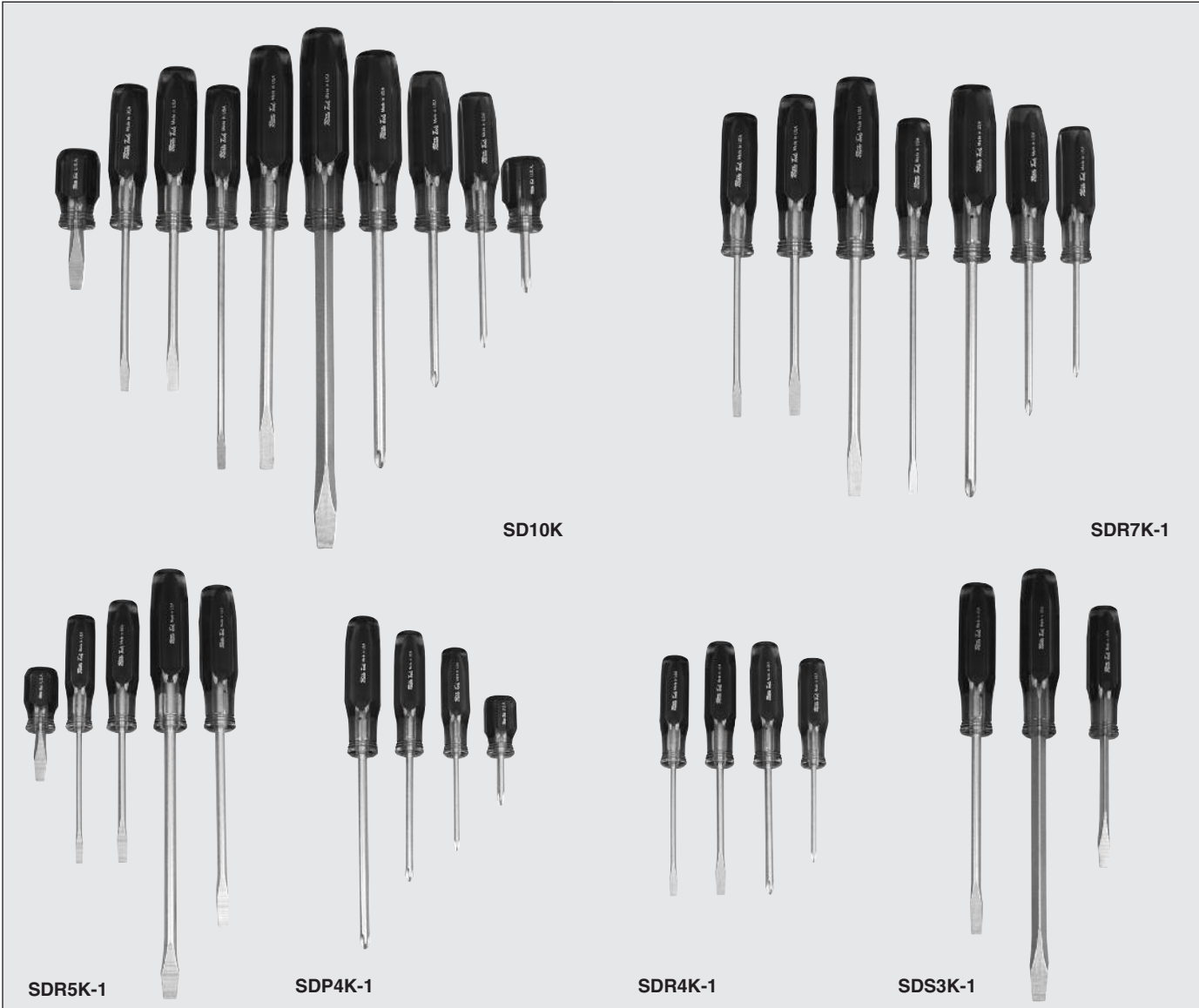

SDR4K-1 4pc Screwdriver Combo Set

SDR4-1	Mechanics, 4"	1/4 Rd-C x 4"
SDE4-1	Electrical, 4"	3/16 Rd-C x 4"
SDP3-1	#1 Phillips, 3"	P1 x 3"
SDP4-1	#2 Phillips, 4"	P2 x 4"
P696	Pouch	

SDR5K-1 5pc Screwdriver Combo Set

SDR4-1	Mechanics, 4"	1/4 Rd-C x 4"
SDE4-1	Electrical, 4"	3/16 Rd-C x 4"
SDR6-1	Mechanics, 6"	5/16 Rd-C x 6"
SDR8-1	Mechanics, 8"	3/8 Rd-K x 8"
SDS1-1	Mechanics, 1-1/2"	1/4 Sq-K x 1.5"
P696	Pouch	

SDR7K-1 7pc Screwdriver Combo Set

SDE4-1	Electrical, 4"	3/16 Rd-C x 4"
SDE6-1	Electrical, 6"	3/16 Rd-C x 6"
SDP3-1	#1 Phillips, 3"	P1 x 3"
SDP4-1	#2 Phillips, 4"	P2 x 4"
SDP6-1	#3 Phillips, 6"	P3 x 6"
SDR4-1	Mechanics, 4"	1/4 Rd-C x 4"
SDR6-1	Mechanics, 6"	5/16 Rd-C x 6"
P496	Pouch	

SDS3K-1 HD Screwdriver Set

SDS4-1	SQ-Blade, 4"	1/4 Sq x 4"
SDS6-1	SQ-Blade, 6"	5/16 Sq x 6"
SDS8-1	SQ-Blade, 8"	3/8 Sq x 8"
P696	Pouch	

SD10K 10pc Screwdriver Combo Set

SDE4-1	Electrical, 4"	3/16 Rd-C x 4"
SDE6-1	Electrical, 6"	3/16 Rd-C x 6"
SDR4-1	Mechanics, 4"	1/4 Rd-C x 4"
SDR6-1	Mechanics, 6"	5/16 Rd-C x 6"
SDS1-1	Mechanics, 1-1/2"	1/4 Sq-K x 1.5"
SDS8-1	SQ-Blade, 8"	3/8 Sq-K x 8"
SDP1-1	#2 Phillips, 1-1/2"	P2 x 1.5"
SDP3-1	#1 Phillips, 3"	P1 x 3"
SDP4-1	#2 Phillips, 4"	P2 x 4"
SDP6-1	#3 Phillips, 6"	P3 x 6"

SDP4K-1 4pc Phillips Set

SDP1-1	#2 Phillips, 1-1/2"	P2 x 1.5"
SDP3-1	#1 Phillips, 3"	P1 x 3"
SDP4-1	#2 Phillips, 4"	P2 x 4"
SDP6-1	#3 Phillips, 6"	P3 x 6"
P696	Pouch	

TOOLS



Heavy-Duty Gasket Scrapers Chisel and Punch Sets



Martin's patented two composite ergonomically designed handle provides maximum comfort and secure grip. Capped end in direct contact with the shaft allows the user to strike the tool without handle damage. Blade extends throughout the handle. Hardened and tempered the entire length for maximum durability

Set contains 1/2" x 10"; 3/4" x 10"; 1" x 10"; 1-1/2" x 10".

- Cleaning gasket material, adhesives and all general scraping in automotive and engineering applications.
- Used for scraping carbon from cylinder heads, pistons and other metal surfaces.

GS4K	Gasket Scraper Set 4 Pc. Heavy Duty Gasket Scraper Set		Wt. 2.5 lb.
GS50	1/2" x 10" Long Gasket Scraper	<ul style="list-style-type: none"> • USA Alloy Steel • Heavy Duty 3/88 Shank 	
GS75	3/4" x 10" Long Gasket Scraper		
GS100	1" x 10" Long Gasket Scraper		
GS150	1-1/2" x 10" Long Gasket Scraper		

Part No.		Size	Weight	Std. Pkg. Qty.
GS50		1/2" x 10"	.57	6
GS75		3/4" x 10"	.57	6
GS100		1" x 10"	.58	6
GS150		1-1/2" x 10"	.59	6

Chisel Sets



CC6K		6 PIECES
C8	1/4" Cold Chisel	
C10	5/16" Cold Chisel	
C12	3/8" Cold Chisel	
C16	1/2" Cold Chisel	
C20	5/8" Cold Chisel	
C24	3/4" Cold Chisel	
C66	KIT BAG	

**WARNING: Never use hammers with "mush-roomed" heads. They may chip and cause injury.
"ALWAYS WEAR SAFETY GOGGLES"**

Punch Sets



PP7K		7 PIECES
P2	1/16" Pin Punch	
P3	3/32" Pin Punch	
P4	1/8" Pin Punch	
P5	5/32" Pin Punch	
P6	3/16" Pin Punch	
P8	1/4" Pin Punch	
P10	5/16" Pin Punch	
C70	KIT BAG	



LP7K		7 PIECES
P23	3/32" Lg. Taper	
P24	1/8" Lg. Taper	
P25	5/32" Lg. Taper	
P26	3/16" Lg. Taper	
P26A	7/32" Lg. Taper	
P27	1/4" Lg. Taper	
P28	5/16" Lg. Taper	
C187	KIT BAG	

Combination Chisel & Punch Sets



PC6K		6 PIECES
C16	1/2" Cold Chisel	
C24	3/4" Cold Chisel	
P42	1/2" Center Punch	
P4	1/8" Pin Punch	
P6	3/16" Pin Punch	
P16	5/16" Solid Punch	
C66	KIT BAG	



PC14K		14 PIECES
C42	1/4" Cape Chisel	
C16	1/2" Cold Chisel	
C20	5/8" Cold Chisel	
C24	3/4" Cold Chisel	
C28	7/8" Cold Chisel	
C60	1/4" Diamond Pt. Chisel	
C72	1/4" Hlf. Rd. Nose Chisel	
P40	3/8" Center Punch	
P24	1/8" Drift Punch	
P25	5/32" Lg. Taper Punch	
P6	3/16" Pin Punch	
P8	1/4" Pin Punch	
P14	5/8" Solid Punch	
P18	1/4" Solid Punch	
C14	KIT BAG	

Punches



WARNING: "ALWAYS WEAR SAFETY GOGGLES"

Prick Punch						Center Punch					
Stock Size	Length	Wt. Ea. Lbs.	Industrial Black	Std. Pkg. Qty.		Point Size	Stock Size	Length	Wt. Ea. Lbs.	Industrial Black	Std. Pkg. Qty.
A	B		Part No.			A	B	C		Part No.	
3/8	5	.14	P32	12		3/32	1/4	3 1/2	.06	P38	12
1/2	6	.27	P33	12		5/32	5/16	4 1/4	.08	P39	12
						3/16	3/8	5	.15	P40	12
						1/4	1/2	6	.30	P42	12
						5/8	5/8	6 1/4	.25	P43	6

Pin Punch							Solid Punch						
Point Size	Stock Size	Length	Pin Length	Wt. Ea. Lbs.	Industrial Black	Std. Pkg. Qty.	Point Size	Stock Size	Length	Taper Length	Wt. Ea. Lbs.	Industrial Black	Std. Pkg. Qty.
A	B	C	D		Part No.		A	B	C	D		Part No.	
1/16	1/4	4	3/4	.05	P2	12	3/32	5/16	5	1 1/4	.02	P13	12
3/32	5/16	4 1/2	7/8	.12	P3	12	1/8	3/8	5	1 3/4	.16	P14	12
1/8	5/16	4 3/4	1	.12	P4	12	3/16	3/8	5	1 1/2	.16	P16	12
5/32	5/16	5	1	.12	P5	12	1/4	3/8	6	1 1/2	.16	P18	12
3/16	3/8	5 1/4	1 1/4	.17	P6	12	5/16	1/2	6	2	.31	P19	12
7/32	3/8	5 1/2	1 1/4	.18	P7	12							
1/4	3/8	5 3/4	1 1/4	.29	P8	12							
5/16	1/2	6	1 1/4	.33	P10	12							

Long Taper Punch						
Point Size	Stock Size	Length	Taper Length	Wt. Ea. Lbs.	Industrial Black	Std. Pkg. Qty.
A	B	C	D		Part No.	
3/32	5/16	8	3 1/2	.12	P23	12
1/8	5/16	8	3 1/2	.16	P24	12
5/32	3/8	9	4 1/4	.25	P25	12
3/16	1/2	10	6 1/2	.45	P26	12
7/32	1/2	10	6 1/2	.45	P26A	12
1/4	5/8	12	7 1/4	.88	P27	6
5/16	5/8	12	7 1/4	.94	P28	6
1/4	3/4	15	7 1/4	1.66	P28A	6
5/16	5/8	16	9 1/2	1.33	P29	6
3/8	3/4	15	8	1.66	P34	6

TOOLS

WARNING: "ALWAYS WEAR SAFETY GOGGLES"

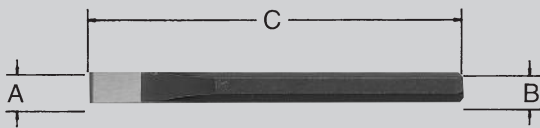
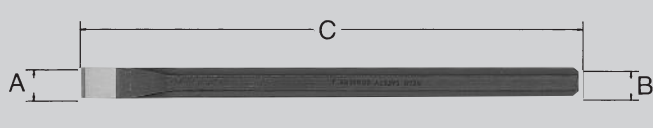
Cold Chisel						Long Cold Chisel					
											
Cut Width	Stock Size	Length	Wt. Ea. Lbs.	Industrial Black	Std. Pkg. Qty.	Cut Width	Stock Size	Length	Wt. Ea. Lbs.	Industrial Black	Std. Pkg. Qty.
A	B	C		Part No.		A	B	C		Part No.	
1/4	1/4	5	.07	C8	12	3/4	5/8	12	1.13	C120	6
5/16	1/4	5	.08	C10	12	5/8	1/2	12	.70	C124	12
3/8	5/16	5 1/2	.13	C12	12	3/4	5/8	18	1.67	C126	3
1/2	7/16	6	.26	C16	12	7/8	3/4	12	1.50	C129	6
5/8	1/2	6 1/2	.37	C20	12	1	3/4	12	1.50	C132	6
3/4	5/8	7	.62	C24	12	1	3/4	18	2.33	C133	3
7/8	3/4	7 1/2	.93	C28	6						
1	3/4	8	1.34	C32	6						

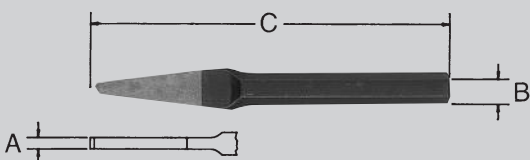
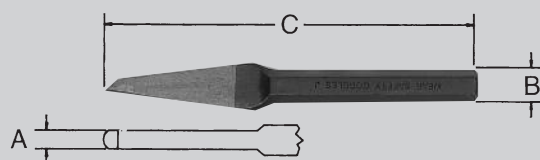
Cape Chisel						Half Round Chisel					
											
Point Size	Stock Size	Length	Wt. Ea. Lbs.	Industrial Black	Std. Pkg. Qty.	Point Size	Stock Size	Length	Wt. Ea. Lbs.	Industrial Black	Std. Pkg. Qty.
A	B	C		Part No.		A	B	C		Part No.	
1/8	5/16	5 1/2	.10	C39	12	3/16	5/8	5 1/2	.16	C71	12
3/16	3/8	5 1/2	.16	C40	12	1/4	3/8	5 1/2	.29	C72	12
1/4	3/8	5 1/2	.29	C42	12						

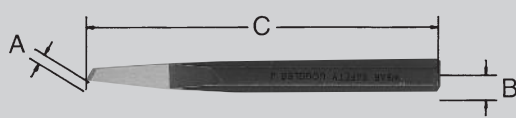
Diamond Point Chisel					
					
Point Size	Stock Size	Length	Wt. Ea. Lbs.	Industrial Black	Std. Pkg. Qty.
A	B	C		Part No.	
1/8	5/16	5	.10	C58	12
3/16	3/8	5 1/2	.18	C59	12
1/4	3/8	5 3/4	.18	C60	12
3/8	5/8	7	.58	C62	6

TOOLS

Pliers – Plastic Grip



Lineman's Plier

Overall Length	Jaw Length	Jaw Width	Jaw Thickness	Wt. Ea. Lbs.	Part No.	Std. Pkg. Qty.
A	B	C	D			
7-1/4	1-1/4	15/16	9/16	0.68	P307	6
8-1/2	1-1/2	1-1/4	9/16	1.00	P308	6

High leverage electrician's general use pliers feature beveled nose, serrated crush area and comfort grip handles.

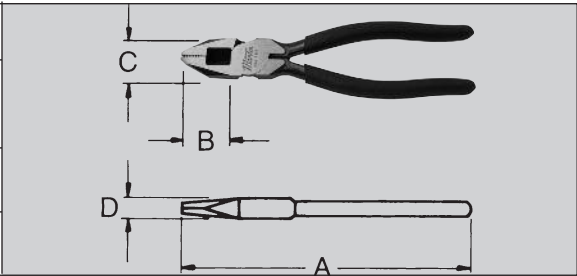

New England Pattern Lineman's Plier

Overall Length	Jaw Length	Jaw Width	Jaw Thickness	Wt. Ea. Lbs.	Part No.	Std. Pkg. Qty.
A	B	C	D			
9-1/2	1-1/2	1-5/16	5/8	1.04	P309	6

Heavy duty, high leverage design features built in connector crimper, fishtape puller, serrated crush area and comfort grips.

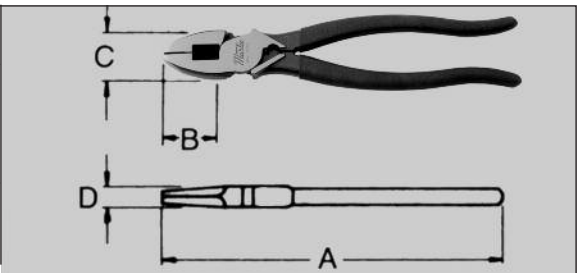

Diagonal Cutting Plier

Overall Length	Jaw Length	Jaw Width	Jaw Thickness	Wt. Ea. Lbs.	Part No.	Std. Pkg. Qty.
A	B	C	D			
6-1/4	7/8	25/32	7/16	0.38	P206	6
7-3/8	1	7/8	7/16	0.52	P2075	6

High leverage comfort grip handles decrease fatigue for easy cutting.

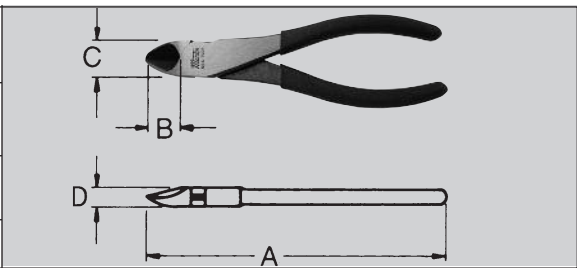

Long Chain Nose Side Cutting Pliers

Overall Length	Jaw Length	Jaw Width	Jaw Thickness	Wt. Ea. Lbs.	Part No.	Std. Pkg. Qty.
A	B	C	D			
6-1/4	2	7/8	13/32	0.32	P506	6
7-7/8	2-5/8	1	7/16	0.49	P507	6

High leverage comfort grip handles for powerful gripping and cutting.

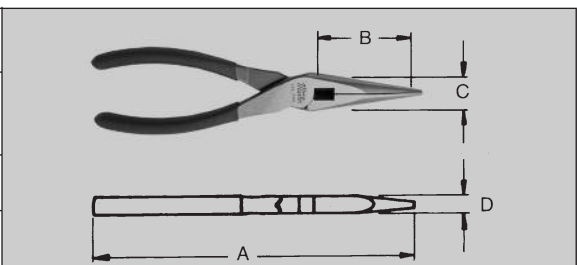

Tongue and Groove Pliers

Overall Length	Jaw Length	Jaw Opening	Jaw Thickness	Wt. Ea. Lbs.	Part No.	Std. Pkg. Qty.
A	B	C	D			
7	13/16	13/16	3/8	0.42	P407	6
9-3/4	1-1/4	1-1/2	7/16	0.92	P510	6
12-7/8	1-11/16	2-3/4	1/2	1.76	P71275	6

Flush Rivet design allows close access to work surfaces and tight areas, undercut adjustment grooves for non-slip grip and comfort grip handles

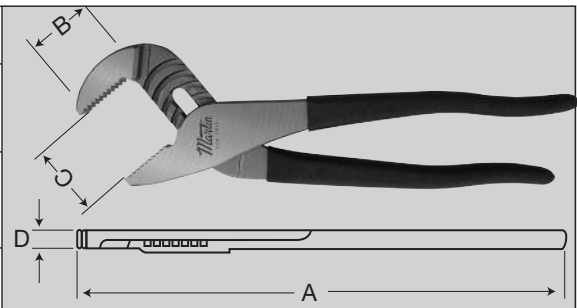

Combination Slip Joint Pliers

Overall Length	Jaw Length	Jaw Width	Jaw Thickness	Wt. Ea. Lbs.	Part No.	Std. Pkg. Qty.
A	B	C	D			
6-3/4	1-13/16	1-1/4	13/32	0.48	P2065	6
8-1/8	2	1-11/32	7/16	0.60	P208	6
10	2-3/8	1-1/2	15/32	0.98	P210	6

Flush rivet design offers three working surfaces, two jaw openings, wire cutter and comfort grips.

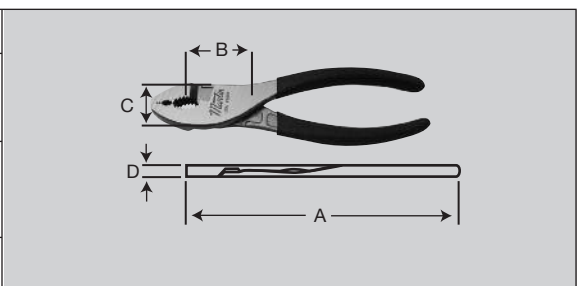



PL3K
3 Pc. General Purpose Pliers Set

P506	6½" Long Chain Nose Side Cutting
P2065	6¾" Combination Slip Joint
P510	9½" Tongue and Groove
P1796	Pouch



PL4K
4 Pc. General Purpose Pliers Set

P507	8" Long Chain Nose Side Cutting
P510	9½" Tongue and Groove
P208	8" Combination Slip Joint
P2075	7" Diagonal Cutting
P1996	Pouch



PL3KSJ
3 Pc. Combination Slip-Joint Pliers Set

P2065	6¾" Combination Slip Joint
P208	8" Combination Slip Joint
P210	10" Combination Slip Joint
P1896	Pouch



PL3KTG
3 Pc. Tongue and Groove Pliers Set

P407	7" Tongue and Groove
P510	9½" Tongue and Groove
P71275	13" Tongue and Groove
P2096	Pouch

Retaining Ring Pliers



One Tool Does it All!

Martin's patented retaining ring pliers are capable of servicing both and external retaining rings. *Martin's* pliers offer superior performance with unique features:

- Reverse on the fly — Switch from Internal to External with one hand.
- Patented Jaws provide positive tip retention and alignment.
- P1421 features an adjustable stop for small rings.
- P75 features an automatic ratchet lock that keeps rings locked open or closed. Ideal for large rings up to 4".

Snap Ring Pliers

Part Number	Description	Internal	External	Weight Ea. Lbs.	Std. Pkg. Qty.
P1421	Quick Switch Retaining Ring Pliers with adjustable stop - Includes 5 pairs of color-coded interchangeable tips and Allen wrench in handy pouch. Tip sizes: Straight- .023", .036", .047" (0.6mm, 0.9mm, 1.2mm) Bent 90° - .036", .047" (0.9mm, 1.2mm)	1/4" - 1" mm - 26mm	1/8" - 1" 3mm - 26mm	0.3	6
P1434	Quick Switch Retaining Ring Pliers - Includes 5 pairs of color-coded interchangeable tips and Allen wrench in handy pouch. Tip sizes: Straight- .036", .047", .070" (0.9mm, 1.2mm, 1.8mm) Bent 90° - .036", .047" (0.9mm, 1.2mm)	3/8" - 2" 10mm - 51mm	1/4" - 2" 7mm - 51mm	0.6	6
P75	Quick Switch Ratcheting Plier - Includes 6 pairs of color-coded interchangeable tips and Allen wrench in handy pouch. Tip sizes: Bent 15° - .090", .108", .120" (2.3mm, 2.7mm, 3.0mm) Bent 90° - .090", .108", .120" (2.3mm, 2.7mm, 3.0mm).	1 1/16" - 4" 46mm - 102mm	1 1/2" - 4" 32mm - 102mm	1.18	6
P87	Retaining Ring Tool - Includes 6 pairs of color-coded interchangeable tips and Allen wrench in handy pouch. Tip sizes: Bent 20° - .120", .150", .180" (3.0mm, 3.8mm, 4.6mm) Bent 90° - .120", .150", .180" (3.0mm, 2.8mm, 4.6mm).	3/8" - 7" 90mm - 175mm	3/8" - 7" 90mm - 175mm	3.05	6



Snap Ring Plier Sets

PL1450K	2 Piece Snap Ring Plier Set w/ Molded Foam Tray Includes P1421 & P1434	0.0	1
PL1465K	3 Piece Snap Ring Plier Set w/ Plastic Box Includes P1421, P1434 & P75	0.0	1

Tip Kits

Part No.	Description	Wt. Ea. Lbs.	Std. Pkg. Qty.
P12K	Tip Kit for P1221 & P1421		
P14K	Tip Kit for P1234 & PP1434		
P651590K	Tip Kit for P65 & P75		
P8720K	Tip Kit 20° for P87		
P8790K	Tip Kit 90° for P87		

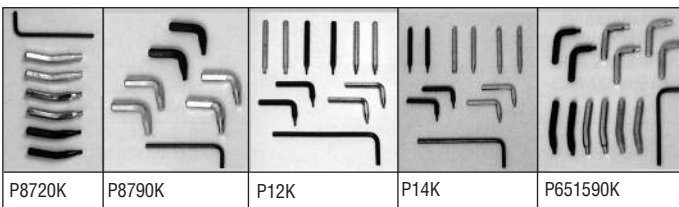

TOOLS

Broached Crank Handles

Square Broached Openings, with Counterbore in Free End of Hub. Special Bends, Offsets, and Broached Openings Also Available.

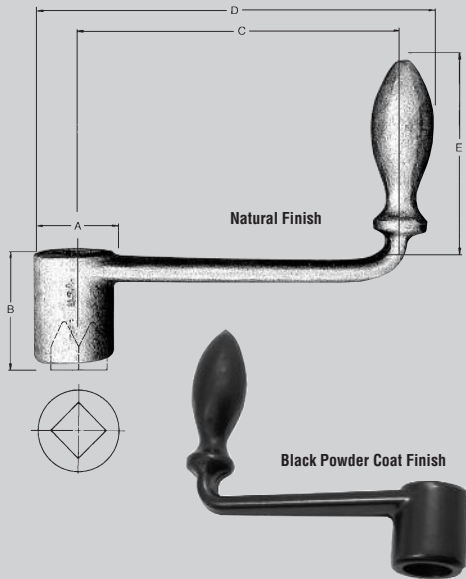

Stock Square Bore	Hub		Length		Height Handle Above Arm	Wt. Ea. Lbs.	Black Powder Coat Finish	Natural Finish	Std. Pkg. Qty.
	Dia.	Length	Center Hub to Center Handle	Overall			Part No.	Part No.	
	A	B	C	D	E				
1/2	1	1 1/2	1 3/4	2 5/8	2 3/4	.46	CH00BC	CH00B	1
1/2	1	1 1/4	2 1/2	3 3/8	2 1/2	.53	CH0BC	CH0B	1
9/16	1 1/4	1 1/2	3	4	2 3/4	.83	CH1BC	CH1B	1
1/2	1 1/8	1 5/16	3 1/2	4 1/2	2 7/8	.74	CH2BC	CH2B	1
9/16	1 1/4	1 3/8	4	5 1/2	3 1/8	1.0	CH4BC	CH4B	1
5/8	1 1/4	1 9/16	5	6 1/8	3 3/8	1.3	CH6BC	CH6B	1
1 1/16	1 1/4	1 15/16	6	7 1/8	3 3/8	1.4	CH8BC	CH8B	1
3/4	1 3/8	2 1/16	7	8 1/4	3 3/8	1.6	CH10BC	CH10B	1
7/8	1 1/2	2 1/8	8	9 3/8	3 3/8	2.3	CH12BC	CH12B	1
7/8	1 1/2	2 1/2	9 1/8	10 1/2	3 3/4	2.7	CH14BC	CH14B	1
1	1 3/4	3	10	11 1/2	4	3.6	CH16BC	CH16B	1

Unfinished Crank Handles

Unfinished Cranks are Plain Forgings Without a Hole in the Hub.

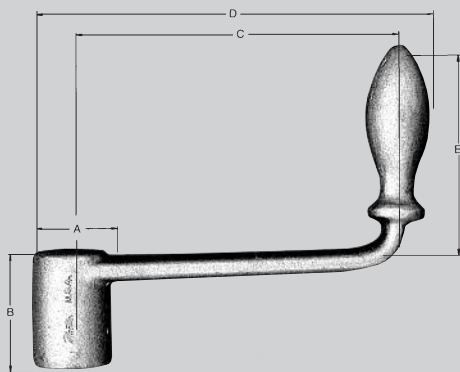

Max Square Bore	Hub		Length		Height Handle Above Arm	Wt. Ea. Lbs.	Natural Finish	Std. Pkg. Qty.
	Dia.	Length	Center Hub to Center Handle	Overall			Part No.	
	A	B	C	D	E			
5/8	1	1 1/2	1 3/4	2 5/8	2 3/4	.46	CH00U	1
5/8	1	1 1/4	2 1/2	3 3/8	2 1/2	.53	CH0U	1
13/16	1 1/4	1 1/2	3	4	2 3/4	.83	CH1U	1
5/8	1 1/8	1 5/16	3 1/2	4 1/2	2 7/8	.74	CH2U	1
13/16	1 1/4	1 3/8	4	5 1/2	3 1/8	1.0	CH4U	1
13/16	1 1/4	1 9/16	5	6 1/8	3 3/8	1.3	CH6U	1
13/16	1 1/4	1 15/16	6	7 1/8	3 3/8	1.4	CH8U	1
7/8	1 3/8	2 1/16	7	8 1/4	3 3/8	1.6	CH10U	1
1	1 1/2	2 1/8	8	9 3/8	3 3/8	2.3	CH12U	1
1	1 1/2	2 1/2	9 1/8	10 1/2	3 3/4	2.7	CH14U	1
1 1/8	1 3/4	3	10	11 1/2	4	3.6	CH16U	1

C-Clamps Eye Bolts Pry Bars



Extra Deep Throat, Copper Plated Fatigue Proof Spindles, Permanent Type Pads.

Inch Capacity	Throat Depth	Spindle Diameter	Minimum Proof Test	Weight Each-Lbs.	Part Number	Std. Pkg. Qty.
0-2	2	1/2	3500 lbs.	1.4	CC402	1
0-3	2 3/8	1/2	3500 lbs.	2.2	CC403	1
0-4	2 3/4	3/4	6500 lbs.	3.4	CC404	1
0-6	3 3/8	3/4	6900 lbs.	5.0	CC406	1
0-8	4 1/2	3/4	6900 lbs.	7.8	CC408	1
0-10	5 3/8	3/4	8000 lbs.	11.0	CC410	1
0-12	5 3/4	7/8	9500 lbs.	15.8	CC412	1



EXTRA DEEP THROAT CLAMP

Shot Blasted Finish Meets ANSI B18.15-1985

A	Threads/Inch	B	Eye		*Rated Capacity	Weight Each-Lbs.	Part Number	Std. Pkg. Qty.
			C	D				
1/4	20	1	3/4	1 1/8	500	.06	EB1	1
5/16	18	1 1/8	7/8	1 1/8	900	.10	EB2	1
3/8	16	1 1/4	1	1 11/16	1300	.15	EB3	1
7/16	14	1 3/8	1 1/16	1 3/8	1800	.21	EB4	1
1/2	13	1 1/2	1 1/8	2 1/8	2400	.30	EB5	1
5/16	12	1 3/4	1 1/4	2 1/4	3000	.55	EB6	1
3/8	11	1 3/4	1 3/8	2 3/8	4000	.61	EB7	1
7/16	10	2	1 1/2	2 3/16	5000	.98	EB8	1
1	8	2 1/2	1 3/4	3 3/8	9000	2.06	EB10	1
1 1/8	7	2 3/4	2	4	12000	2.90	EB11	1
1 1/4	7	3	2 3/16	4 3/8	15000	4.11	EB12	1
1 1/2	6	3 1/2	2 1/2	5 3/8	21000	6.73	EB14	1

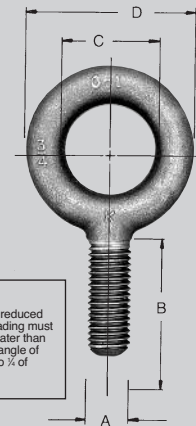

WARNING
Rated capacity is substantially reduced when loading at any angle. Loading must never be made at an angle greater than 45° from bolt centerline. At an angle of 45° rated capacity is reduced to 1/2 of shown rating.

EYEBOLTS PLAIN PATTERN

Shot Blasted Finish Meets ANSI B18.15-1985

A	Threads/Inch	B	Eye		E	*Rated Cpty.-Lbs.	Weight Each-Lbs.	Part Number	Std. Pkg. Qty.
			C	D					
1/4	20	1	3/4	1 1/8	1 1/16	500	.06	EB21	1
5/16	18	1 1/8	7/8	1 1/8	7/8	900	.11	EB22	1
3/8	16	1 1/4	1	1 11/16	1 1/8	1300	.18	EB23	1
7/16	14	1 3/8	1 1/16	1 3/8	1 3/8	1800	.23	EB24	1
1/2	13	1 1/2	1 1/8	2 1/8	1 1/8	2400	.35	EB25	1
5/16	12	1 3/4	1 1/4	2 1/4	1 1/2	3000	.47	EB26	1
3/8	11	1 3/4	1 3/8	2 3/8	1 13/32	4000	.70	EB27	1
7/16	10	2	1 1/2	2 3/16	1 29/32	5000	1.10	EB28	1
1	8	2 1/2	1 3/16	3 3/8	2 1/2	9000	1.70	EB29	1
1 1/8	7	2 3/4	2	4 1/8	2 19/32	12000	2.36	EB30	1
1 1/4	7	3	2 3/16	4 3/8	2 27/32	15000	3.41	EB31	1
1 1/2	6	3 1/2	2 1/2	5 3/8	3 3/8	21000	4.68	EB32	1
							7.77	EB34	1

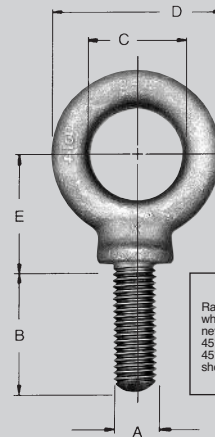

WARNING
Rated capacity is substantially reduced when loading at any angle. Loading must never be made at an angle greater than 45° from bolt centerline. At an angle of 45° rated capacity is reduced to 1/2 of shown rating.

EYEBOLTS SHOULDER PATTERN

Pinch or Pry Bar



Die Bar — Pry Bar



Size	Length	Wt. Ea. Lbs.	Bright Zinc	Industrial Black	Std. Pkg. Qty.	Size	Length	Wt. Ea. Lbs.	Chrome	Industrial Black	Std. Pkg. Qty.
			Part No.	Part No.					Part No.	Part No.	
5/8	16	1.3	196C	196	1	1/2	12	.70	192C	192	1
3/4	24	3.0	197C	197	1	1/2	15	.87	193C	193	1
7/8	30	5.25	198C	198	1	5/8	18	1.6	194C	194	1

J-96 **WARNING: Never substitute a pry bar with a screwdriver. "ALWAYS WEAR SAFETY GOGGLES"**

Only *Martin* Provides This Added Warranty —
If a Hammer Head Should Loosen at Any Time, Return
It for Handle Replacement or a New Hammer.

Type	Image	Description	Body Hammers Part No.		Std. Pkg. Qty.
			Wood Handles	Fiberglass Handles	
DINGING HAMMER		For fender and high-crowned panel dinging or bumping. Both high and low-crown faces for "on or off dolly" work. Faces, 1¼" and 1½". Round heads, 6" overall. Weight 1.04 lbs.	150G	150FG	6
DINGING HAMMER		For light dinging and long reach. Square face permits dinging close to moulding or beading. Faces, 1¼" round, 1½" square head 6" overall. Weight .85 lbs.	151G	—	6
HIGH CROWN CROSS PEEN HAMMER		Two high-crowned faces for concave surfaces on doors, rear quarter panels, fenders and hoods. Faces 1½", 6" overall. Weight 1.02 lbs.	152G	—	6
CROSS CHISEL HAMMER		Excellent for finishing. Cross peen used for working in sharp corners around mouldings and for caulking. Round face — 1⅞" diameter. Chisel — 3" long. Weight .87 lbs.	153G	153FG	6
CURVED CROSS CHISEL HAMMER		Excellent for finishing. Cross peen used for working in sharp corners around mouldings and for caulking. Well balanced curved chisel for work in close places. Round face — 1⅞" diameter. Chisel — 3" long. Weight .85 lbs.	153GB	153FGB	6
CROSS CHISEL SHRINKING HAMMER		Cross grooved. Extra wide faces are cross grooved and used for shrinkage on large surfaces — chisel end used on sharp corners. Flat round face — 1⅞" diameter. Chisel — 3" long. Weight .87 lbs.	153S	—	6
VERTICAL CHISEL HAMMER		Excellent for finishing. Cross peen used for working in sharp corners around mouldings and for caulking. Vertical chisel end used on sharp corners. Round face — 1½" diameter. ⅝" Chisel — 5½" long. Weight .85 lbs.	154G	154FG	6
VERTICAL CHISEL SHRINKING HAMMER		Cross grooved. Extra wide faces are cross grooved and used for shrinkage on large surfaces — vertical chisel end used on sharp corners. Round face — 1½" diameter. Chisel — 5½" long. Weight .87 lbs.	154S	154SFG	6
FENDER BUMPER		For bumping where hand and dolly cannot reach. Ample clearance for obstructions. Also used as a caulking iron. Length of head, 8¾". Weight 2.8 lbs.	155G	155FG	4
PICK HAMMER		Long-reach, thin point for low spot on low-crown panels. Reaches over inner obstructions. One high-crown face. Face, 1¼" round point, ½" radius. Length of pointed end, 5½". Weight .91 lbs.	156G	156FG	6
CURVED PICK HAMMER		Like 156G except pick end is bent in arc of normal blow. Reaches behind reinforcements to difficult spots. Face, 1¼" round point, ½" radius. Length of pointed end, 5½". Weight .86 lbs.	156GB	—	6

Body Hammers









Only *Martin* Provides This Added Warranty —
If a Hammer Head Should Loosen at Any Time, Return
It for Handle Replacement or a New Hammer.

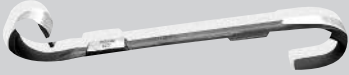

Type		Description	Body Hammers Part No.		Std. Pkg. Qty.
			Wood Handles	Fiberglass Handles	
GENERAL PURPOSE PICK HAMMER		Medium size point and reach for general work. Low crown strawberry point for perfect balance. Face, 1¹/₁₆" round point, 3¹/₃₂" radius. Length of pick end, 3³/₄". Weight .91 lbs.	158G	158FG	6
ROUND POINT FINISHING HAMMER		Blunt point — long reach. For low spots on high crown panels and other work with long reach. Will not pick holes in the metal. Round face — 1¹/₁₆" diameter. Blunt point 3" long. Weight .81 lbs.	158GM	158FGM	6
SHARP POINT FINISHING HAMMER		Sharp point — long reach. For low spots on high crown panels and other work with long reach. Round face — 1¹/₁₆" diameter. Sharp point 3" long. Weight .79 lbs.	158GMS	—	6
HEAVY DUTY BUMPING HAMMER		For heavy gauge truck fenders and panels. Also used in straightening reinforcements, braces, etc. Faces, 1¹/₄" round and 1¹/₁₆" square head, 4" overall. Weight 1.1 lbs.	160G	160FG	6
DINGING HAMMER		Short-reach, lightweight. One low-crown, square face. Lightest dinging hammer in line. Faces, 1¹/₄" round and 1¹/₁₆" square. Head, 4" overall. Weight .83 lbs.	161G	161FG	6
SHRINKING HAMMER		For work in close quarters. Expertly machined serrations on the round face. Plain square face, 1¹/₄" round serrated face, 1¹/₄" diameter. 4" overall. Weight .78 lbs.	162G	162FG	6
UTILITY PICK HAMMER		Blunt point, short reach. For low spots in high-crown panels and other work with small clearance. Face, 1¹/₁₆" round point, 3¹/₃₂" radius. Length of pointed end, 2" head, 4" overall. Weight .75 lbs.	164G	164FG	6
PICK HAMMER		Lightweight. Provides stubby pick point and high-crown peen-type faces. Will ding out small dents in high fins. No need to remove panels. Long reach, 18" handle. Weight 5 oz.	165G	—	6
PICK HAMMER		Lightweight. Provides stubby pick point and high-crown peen-type faces. Will ding out small dents in high fins. No need to remove panels. 12" handle. Weight 4 oz.	166G	—	6
CROSS PEEN FINISHING HAMMER		Used to bump odd fender or bumper contours. Round face — 1¹/₁₆" diameter peen end 3¹/₁₆ x 7¹/₈". 5" overall head length. 12" handle. Weight .91 lbs.	168G	168FG	6
HIGH CROWN CROSS PEEN FINISHING HAMMER		Ideal for forming radiuses, contours and curves-restoration, bike tanks. High Crown face — 1¹/₁₆" diameter. 2¹/₄" radius. Peen end 3¹/₁₆" x 1". 5" overall head length. 12" handle. Weight 1.0 lbs.	168HC	168HCFG	6
LARGE FACE PICK FINISHING HAMMER		For finishing and caulking. Round face — 1¹/₁₆" diameter. 4¹/₂" overall head length. 13" handle. Weight 1.0 lbs.	169G	169FG	6
DOOR SKIN HAMMER		Rectangular heads fit in door flanges. Bent Head - medium crown - starts door skin fold. Straight head - high crown - for finishing. 7" overall length. Weight .94 lbs.	170G	170FG	6

Type		Description	Part No.	Std. Pkg. Qty.
LIGHT WEIGHT TOE DOLLY		Designed for flat surfaces. All the features of a toe dolly. Sizes 4$\frac{3}{4}$" x 2$\frac{1}{4}$" x $\frac{1}{16}$". Weight 1.8 lbs.	1057	1
TOE DOLLY		Thinness and length provide easy accessibility to narrow pockets. Large, flat face is frequently used in shrinking and dinging flat panels. The flat sides furnish a convenient anvil for repairing flanges. Sizes 4$\frac{3}{4}$" x 2$\frac{3}{8}$" x 1$\frac{1}{8}$". Weight 3.0 lbs.	1058	1
SHRINKING DOLLY (SERRATED)		Shaped like a toe dolly but has one face covered with raised serrations for shrinking metal stretched by dents. Weight 3.4 lbs.	1058S	1
HEEL DOLLY		Design makes it possible to reach easily into sharp corners and wide radii. These features are exclusive to the Heel Dolly and continue its high demand. Sizes 3$\frac{1}{4}$" x 2$\frac{1}{2}$" x 1$\frac{1}{8}$". Weight 2.7 lbs.	1059	1
GENERAL PURPOSE DOLLY		Provides convenient and comfortable hand hold during heaviest blows. Weight, balance and several differently crowned working faces, together with two beading and flange lips, give this dolly broad general use. Sizes 2$\frac{7}{8}$" x 2$\frac{3}{8}$" x 2$\frac{1}{4}$". Weight 3 lbs.	1060	1
UTILITY DOLLY		High-crown dolly with one narrow beading edge. Thick rounded sides are useful in short radii curves. Wide application of uses in high-crown portions of hoods, fenders and body panels. Sizes 3$\frac{3}{8}$" x 3" x 1$\frac{1}{8}$". Weight 2.9 lbs.	1061	1
EGG SHAPED DOLLY		This unique shape with high crown design is a very popular shape, with many different curves and angles. Sizes 1$\frac{5}{8}$" x 2$\frac{1}{2}$" x 3$\frac{3}{4}$". Weight 3.1 lbs.	1064	1
WEDGE DOLLY		Long, slender general purpose dolly. Widely favored by many body repair men for all-around use. The long, thin lip is very useful in working behind reinforcements. Sizes 5$\frac{3}{4}$" x 2$\frac{3}{8}$" x 2$\frac{1}{16}$". Weight 4 lbs.	1067	1
LIGHT WEIGHT WEDGE DOLLY		Short, slender general purpose Dolly. Good hand grip. Also used for beads or flanges on fenders. Thin edge is useful for corners and beading. Flat side works under long curve of fender Size 2$\frac{3}{4}$" x 2$\frac{1}{2}$" x 4$\frac{7}{16}$". Weight 2.7 lbs.	1065	1
"CHAMPION" HEAVYWEIGHT DOLLY		Heavy duty, general purpose fender dolly. A necessity on heavy gauge fenders which resist the blows of lighter dollies. Brings out the toughest damage. Seats comfortably in the hand and protects fingers from a swinging blow. Sizes 3$\frac{3}{8}$" x 3$\frac{3}{8}$" x 2$\frac{1}{16}$". Weight 4.6 lbs.	1070	1
LOW CROWN DOLLY		Specially designed for use on low-crown panels where medium and high-crown dollies would stretch the metal. Angle between the sides and large face is less than 90°, which permits this dolly to reach into the corner of a flanged edge. Size 3$\frac{3}{8}$" x 2$\frac{3}{4}$" x 1$\frac{1}{8}$". Weight 3.3 lbs.	1068	1

Body and Fender Repair Tools

Body Spoons

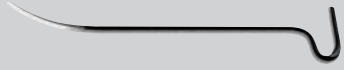
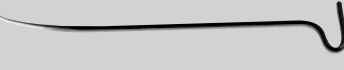
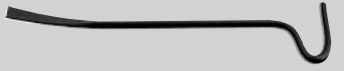

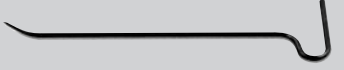
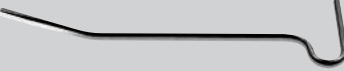
Type		Description	Part No.	Std.
LIGHT DINGING SPOON		To ding ridges smooth and level. When held against ridge and struck with hammer, spreads blow over large area making smooth job and preventing damage to metal or finish. Not made for prying. Length 10" overall. Face 2" x 4⁵/₁₆". Weight .50 lbs.	1036	6
COMBINATION SPOON		General purpose fender spoon. Used as dolly behind brackets, inner panels and similar places. Handle offset to give balance when dinging and for long reach. Has high-crown working surface. Face 1¹/₄" x 5¹/₂". Handle 1" octagon 4³/₄" long. Weight 3.0 lbs.	1050	4
SPOON DOLLY		Long handle permits many uses in places otherwise inaccessible. Can be driven between reinforcements and outer panel, then used to pry outward as the metal is dinged. Excellent forming and caulking tool for the deep pockets of doors, quarter-panels, rear fenders and lower trunk panels. Size 2¹/₂" x 1" x 3". Weight 4.2 lbs.	1052	1
LONG CURVED SPOON		Long, thin, curved blade is handy for prying up dents behind curved reinforcements in header panels, hinge anchors in doors, body pillars and reinforcements in hoods and radiator shells. Length 10¹/₂" overall. Face 2" x 7". Weight 1.5 lbs.	1054	6
WING-DING SPOON DOLLY		The answer to repair problems on high fins. A dolly, a spoon, a pry. Long handle and special contours for working up inside cramped fins. Wide spoon transmits hammer blows over wide area without damaging finish. 1" handle diameter, 19" overall length. Weight 4.5 lbs.	1056	1
HEAVY DUTY DRIVING AND FENDER BENDING TOOL		Useful for restoration of turned under, non-wired flanged edges. Also handy for alignment of inner construction and flanges on alligator hoods. Heavy formed striking pads. Length 14¹/₂". Weight 3.2 lbs.	1091	1
CAULKING IRON		Excellent precision made wire caulking iron. Polished working surfaces are rounded for use on inside moldings. Face 1¹/₄" x 1". Overall length 11". Weight 1.4 lbs.	1096C	6
SURFACING SPOON		Excellent spoon for fender spring hammering, finishing and shaping. Curve gets behind inner construction between panels that are close for removal of dents. Molds panels. Blade fully polished. 9" Blade Length. 2¹/₄" Width. Overall Length 15¹/₈". Weight 2.5 lbs.	1024	1
MEDIUM CROWN SPOON		Long slender shape just like the 1024 surfacing spoon. Inside with medium crown, for high ridges or prying. For slapping and surface finishing on fenders, panels and trunk lids. Blade fully polished. 9" Blade Length. 2¹/₄" Width. Overall Length 14¹/₈". Weight 1.5 lbs.	1026	1
HEAVY DUTY DOUBLE END S-SPOON		General purpose fender and frame spoon. Designed to provide further reach on panels and behind reinforcements. Prying, heavy duty design for use on SUV frames. 12³/₁₆" Length. 1¹/₂" x 5¹/₄" Face. Weight 3.0 lbs.	1044	1

		Description		
MEDIUM CURVED PICK		Medium length. Curved and pointed. Use twisting or prying action. Length 26½" . Weight 2.2 lbs.	1106	1
LONG CURVED PICK		Long length. Curved and pointed. Use twisting or prying action. Length 31" . Weight 2.5 lbs.	1107	1
LONG CHISEL BIT PICK		Heavy duty. Employ twisting action. Chisel bit 1" . Length 20" . Weight 1.9 lbs.	1109	1
SHORT CURVED PICK		Extremely short length. Curved and pointed. Use twisting or prying action. Length 12" . Weight .5 lbs.	1110	1
MEDIUM SHORT CURVED PICK		Short length. Curved and pointed. Use twisting or prying action. Length 18" . Weight .7 lbs.	1111	1
LIGHT CHISEL BIT PICK		Light duty. Employ twisting action. Chisel bit 1¼" . Length 16" . Weight .7 lbs.	1112	1

Body and Fender Repair Tools

Miscellaneous Tools

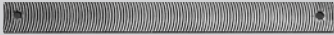

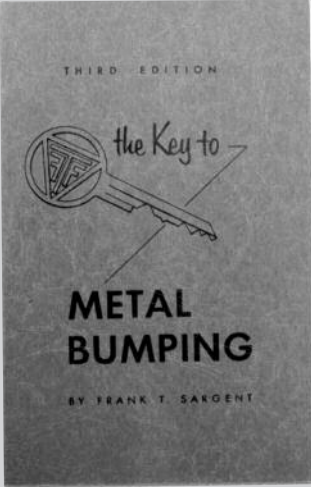
		Description		
ADJUSTABLE AND FLEXIBLE FILE HOLDERS		Permits use of files to 14". Handle adjustable for both right and left hand use for working close to offset or panels. Permit flexing either way to maximum point of safety against breakage. Weight 1.7 lbs.	1150	1
STANDARD 14" BODY FILE		Vixen milled, curved tooth. Plain blade. Flexible, standard cut, 8 tooth. 14" long. Weight .66 lbs.	1158F	5
STRAIGHT SHELL BODY FILE		Vixen milled, curved tooth. Plain blade. Half round shell, 8 tooth. Concave for shallow concave work. 14" long. Weight .66 lbs.	1163F	5
BODY DENT PULLER TOOL		Slide hammer activated. This tool provides a remarkably simple and easy method of removing a dent in a door or panel. Merely punch or drill a hole in the deepest part of the damage and insert a self-threading screw or hook. A few light impacts with the slide hammer will return the metal to original position. Shaft is 1/2" x 13" with locking device to keep screw from turning. Cadmium and black oxide rust-proof finish. Weight 3.9 lbs.	DP38	1
THE KEY TO METAL BUMPING		This book, entitled "The Key to Metal Bumping," is an excellent instruction manual and guide for every body man or student. It provides authoritative reference for techniques and methods for all phases of body and fender work. Its 126 pages cover most approaches to body repair problems. Visual assistance is rendered by more than 100 illustrations. It includes explanations of many time-saving short-cut methods to make the job easier and better. Among other features is a glossary of terms used in the trade. This is the third edition. The first was published in the late thirties and over the years has enjoyed widespread acceptance and usage as a guide and test by many public, private and trade schools. It is a perfect "tool of the trade" for the student and journeyman alike.	BFB	1

TOOLS

Body and Fender Repair Tool Sets

PART NO.	659 K
153G.....	Cross Chisel Straight Hammer
158G.....	General Purpose Pick Hammer
160G.....	Heavy Duty Bumping Hammer
164G.....	Utility Pick Hammer
1058.....	Toe Dolly Block
1059.....	Heel Dolly Block
1060.....	General Purpose Dolly Block
1036.....	Light Dinging Spoon
1150.....	Adjustable File Holder
1158F.....	Body File Standard 14"
BFB.....	Instruction Manual
BX18.....	Tool Box



PART NO.	691 K
153G.....	Cross Chisel Straight Hammer
156G.....	Pick Hammer
158G.....	General Purpose Pick Hammer
160G.....	Heavy Duty Bumping Hammer
161G.....	Dinging Hammer
164G.....	Utility Pick Hammer
1058.....	Toe Dolly Block
1059.....	Heel Dolly Block
1060.....	General Purpose Dolly Block
1036.....	Light Dinging Spoon
1052.....	Spoon Dolly
1050.....	Combination Spoon
1150.....	Adjustable File Holder
1158F.....	Body File Standard 14"
162G.....	Shrinking Hammer
BFB.....	Instruction Manual
BX18.....	Tool Box



PART NO.	692 K
150G.....	Dinging Hammer
153G.....	Cross Chisel Straight Hammer
153GB.....	Cross Chisel Curved Hammer
155G.....	Fender Bumper
156G.....	Pick Hammer
156GB.....	Curved Pick Hammer
158G.....	General Purpose Pick Hammer
160G.....	Heavy Duty Bumping Hammer
161G.....	Dinging Hammer
162G.....	Shrinking Hammer
164G.....	Utility Pick Hammer
168G.....	Cross Peen Finishing Hammer
169G.....	Large Face Pick Finishing Hammer
1036.....	Light Dinging Spoon
1050.....	Combination Spoon
1052.....	Spoon Dolly
1054.....	Long Curved Spoon
1058.....	Toe Dolly Block
1059.....	Heel Dolly Block
1060.....	General Purpose Dolly Block
1061.....	Utility Dolly Block
1068.....	Low Crown Dolly Block
1091.....	Heavy Duty Driving Spoon
1150.....	Adjustable File Holder
1158F.....	Body File Standard 14"
BFB.....	Instruction Manual
BX17.....	Tool Box



Body and Fender Repair Tools Tool Sets



<table border="1"> <thead> <tr> <th>Part No.</th> <th>644K</th> <th>WOOD HANDLES</th> </tr> </thead> <tbody> <tr> <td>158G</td> <td>General Purpose Pick Hammer</td> <td></td> </tr> <tr> <td>153GB</td> <td>Cross Chisel Curved Hammer</td> <td></td> </tr> <tr> <td>1036</td> <td>Light Dinging Spoon</td> <td></td> </tr> <tr> <td>1058</td> <td>Toe Dolly Block</td> <td></td> </tr> </tbody> </table>	Part No.	644K	WOOD HANDLES	158G	General Purpose Pick Hammer		153GB	Cross Chisel Curved Hammer		1036	Light Dinging Spoon		1058	Toe Dolly Block		<p style="text-align: center;">4 TOOLS</p>
Part No.	644K	WOOD HANDLES														
158G	General Purpose Pick Hammer															
153GB	Cross Chisel Curved Hammer															
1036	Light Dinging Spoon															
1058	Toe Dolly Block															
<table border="1"> <thead> <tr> <th>Part No.</th> <th>644KFG</th> <th>FIBERGLASS HANDLES</th> </tr> </thead> <tbody> <tr> <td>158FG</td> <td>General Purpose Pick Hammer</td> <td></td> </tr> <tr> <td>153FGB</td> <td>Cross Chisel Curved Hammer</td> <td></td> </tr> <tr> <td>1036</td> <td>Light Dinging Spoon</td> <td></td> </tr> <tr> <td>1058</td> <td>Toe Dolly Block</td> <td></td> </tr> </tbody> </table>	Part No.	644KFG	FIBERGLASS HANDLES	158FG	General Purpose Pick Hammer		153FGB	Cross Chisel Curved Hammer		1036	Light Dinging Spoon		1058	Toe Dolly Block		
Part No.	644KFG	FIBERGLASS HANDLES														
158FG	General Purpose Pick Hammer															
153FGB	Cross Chisel Curved Hammer															
1036	Light Dinging Spoon															
1058	Toe Dolly Block															
<table border="1"> <thead> <tr> <th>Part No.</th> <th>647K</th> <th>WOOD HANDLES</th> </tr> </thead> <tbody> <tr> <td>153GB</td> <td>Cross Chisel Curved Hammer</td> <td>1058 Toe Dolly Block</td> </tr> <tr> <td>162G</td> <td>Shrinking Hammer</td> <td>1059 Heel Dolly Block</td> </tr> <tr> <td>164G</td> <td>Utility Pick Hammer</td> <td>1060 General Purpose Dolly Block</td> </tr> <tr> <td>1036</td> <td>Light Dinging Spoon</td> <td></td> </tr> </tbody> </table>	Part No.	647K	WOOD HANDLES	153GB	Cross Chisel Curved Hammer	1058 Toe Dolly Block	162G	Shrinking Hammer	1059 Heel Dolly Block	164G	Utility Pick Hammer	1060 General Purpose Dolly Block	1036	Light Dinging Spoon		<p style="text-align: center;">7 TOOLS</p>
Part No.	647K	WOOD HANDLES														
153GB	Cross Chisel Curved Hammer	1058 Toe Dolly Block														
162G	Shrinking Hammer	1059 Heel Dolly Block														
164G	Utility Pick Hammer	1060 General Purpose Dolly Block														
1036	Light Dinging Spoon															
<table border="1"> <thead> <tr> <th>Part No.</th> <th>647KFG</th> <th>FIBERGLASS HANDLES</th> </tr> </thead> <tbody> <tr> <td>153FGB ...</td> <td>Cross Chisel Curved Hammer</td> <td>1058.. Toe Dolly Block</td> </tr> <tr> <td>162FG</td> <td>Shrinking Hammer</td> <td>1059.. Heel Dolly Block</td> </tr> <tr> <td>164FG</td> <td>Utility Pick Hammer</td> <td>1060.. General Purpose Dolly Block</td> </tr> <tr> <td>1036</td> <td>Light Dinging Spoon</td> <td></td> </tr> </tbody> </table>	Part No.	647KFG	FIBERGLASS HANDLES	153FGB ...	Cross Chisel Curved Hammer	1058.. Toe Dolly Block	162FG	Shrinking Hammer	1059.. Heel Dolly Block	164FG	Utility Pick Hammer	1060.. General Purpose Dolly Block	1036	Light Dinging Spoon		
Part No.	647KFG	FIBERGLASS HANDLES														
153FGB ...	Cross Chisel Curved Hammer	1058.. Toe Dolly Block														
162FG	Shrinking Hammer	1059.. Heel Dolly Block														
164FG	Utility Pick Hammer	1060.. General Purpose Dolly Block														
1036	Light Dinging Spoon															
<table border="1"> <thead> <tr> <th>Part No.</th> <th>694K</th> <th>WOOD HANDLES</th> </tr> </thead> <tbody> <tr> <td>158G</td> <td>General Purpose Pick Hammer</td> <td></td> </tr> <tr> <td>153GB</td> <td>Cross Chisel Curved Hammer</td> <td></td> </tr> <tr> <td>164G</td> <td>Utility Pick Hammer</td> <td></td> </tr> <tr> <td>170G</td> <td>Door Skin Hammer</td> <td></td> </tr> </tbody> </table>	Part No.	694K	WOOD HANDLES	158G	General Purpose Pick Hammer		153GB	Cross Chisel Curved Hammer		164G	Utility Pick Hammer		170G	Door Skin Hammer		<p style="text-align: center;">4 TOOLS</p>
Part No.	694K	WOOD HANDLES														
158G	General Purpose Pick Hammer															
153GB	Cross Chisel Curved Hammer															
164G	Utility Pick Hammer															
170G	Door Skin Hammer															
<table border="1"> <thead> <tr> <th>Part No.</th> <th>694KFG</th> <th>FIBERGLASS HANDLES</th> </tr> </thead> <tbody> <tr> <td>158FG</td> <td>General Purpose Pick Hammer</td> <td></td> </tr> <tr> <td>153FGB ...</td> <td>Cross Chisel Curved Hammer</td> <td></td> </tr> <tr> <td>164FG</td> <td>Utility Pick Hammer</td> <td></td> </tr> <tr> <td>170FG</td> <td>Door Skin Hammer</td> <td></td> </tr> </tbody> </table>	Part No.	694KFG	FIBERGLASS HANDLES	158FG	General Purpose Pick Hammer		153FGB ...	Cross Chisel Curved Hammer		164FG	Utility Pick Hammer		170FG	Door Skin Hammer		
Part No.	694KFG	FIBERGLASS HANDLES														
158FG	General Purpose Pick Hammer															
153FGB ...	Cross Chisel Curved Hammer															
164FG	Utility Pick Hammer															
170FG	Door Skin Hammer															