

Martin SPROCKET & GEAR, INC.



Quadra-flex[®] FLEXIBLE COUPLINGS



**STOCKED NATIONWIDE
IN SIZES 3 THROUGH 16**

**STYLES J, S, B, AND
SC SPACERS**



Couplings

Whatever Your Need For Couplings — Martin Has Them

Martin Offers Two Complete Lines of Jaw Couplings — One for Greater Horsepower and One for Interchangeability.



ML — Type



MS — Type

Martin QD Flex® — Today's Most Advanced Coupling. For High Strength, Better Balance, Easy Installation, and the Strong Shaft Fit of the QD Bushing.



For the Most Complete Line of Chain Couplings Available.



S/B



BS



TB



QD



Aluminum



Plastic

Martin QUADRA-FLEX® • A Proven Design Which Offers Long Life, Torsional Flexibility, Ease of Installation, and Withstands Misalignment, Shock, and Vibration.





Martin QUADRA-FLEX® Couplings, Non Lubricated,
Maintenance Free, Easy and Quick Installation

Handles All Combinations of Shock, Vibration, and Misalignment

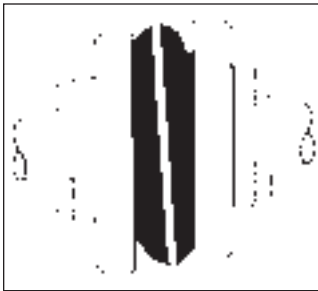

Parallel

QUADRA-FLEX® couplings absorb parallel misalignment without wear and with minimal loss of energy. The amount of parallel offset handled varies by size from .015" on the size 5 up to .062" on the size 16. This minimizes the radial loads on bearings when parallel misalignment occurs.

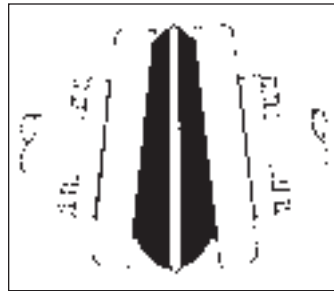

Angular

Due to the flexing characteristics of the sleeve and the locking action of the teeth, QUADRA-FLEX® couplings easily handle angular misalignment up to 1 degree without any appreciable wear.

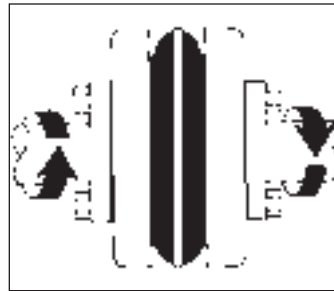

Torsional

QUADRA-FLEX® sleeves are torsionally resilient and are well suited to absorbing shocks and dampening vibrations that would otherwise be transmitted between the equipment.

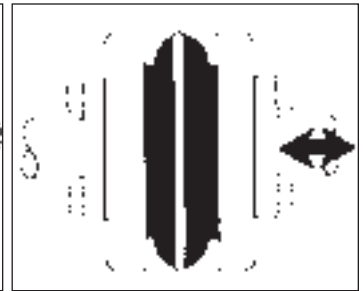

Axial

The axial flexibility of the sleeve allows the QUADRA-FLEX® coupling to accept a limited amount of end float. This serves to reduce thrust loads transferred to bearings. QUADRA-FLEX® units will accept axial movement of approximately 1/8".

Available in Three Styles

Type J and S Flanges

Bored-to-size flanges are manufactured for a slip fit on standard shafting. Available from stock in a wide range of shaft sizes.



Type B Flanges

Manufactured from high strength cast iron to fit standard QD bushings in sizes 6 thru 16.



Fast Coupling Disassembly

Martin offers the first true drop-out spacer assembly for the 4JSC spacer coupling. The center portion of the spacer can be taken out, just as in the 5SC thru 14SC, by simply removing four cap screws in each hub. The couplings center section can then be lifted out and the pump gaskets exposed. Flats on the spacer hubs facilitate turning shafts with a wrench.



Type SC Spacer Flange

QUADRA-FLEX® SC Spacer Couplings feature all standard spacing requirements for the pump industry. Spacer sizes range from sizes 4 thru 14.





QUADRA-FLEX® Nomenclature

Flanges

Type	Description
J★	SINTERED STEEL, BORE-TO-SIZE
S	CAST IRON, BORED-TO-SIZE
B	CAST IRON, QD BUSHED
SC	SPACER COUPLING FLANGES

★ — #6 Currently Supplied in Cast Iron

Hubs – (For SC flanges)

Type	Description
H	REGULAR LENGTH
HS	SHORT LENGTH

Sleeves

Type	Description
JEM	TPR – 1-PIECE SOLID, THERMOPLASTIC
JEMS	TPR – 1-PIECE SPLIT, THERMOPLASTIC
EM	TPR – 2-PIECE W/RETAINING RING
E	EPDM – 2-PIECE W/RETAINING RING
N	NEOPRENE – 2-PIECE W/RETAINING RING
H	HYTREL – 1-PIECE SOLID
HS	HYTREL – 2-PIECE

QUADRA-FLEX® couplings come in a variety of styles and designs to meet specific customer needs. These include flanges and sleeves of various types and materials. The total product line includes 13 sizes varying in torque ratings up to 72,000 in-lbs.

When ordering QUADRA-FLEX® couplings, the following basic procedure should help expedite order processing. For coupling flanges, give the basic coupling size, then the letter for the type flange followed by the bore size required. For coupling sleeves, give the coupling size followed by the letter(s) designating the type and material required. (See above)

The following are various examples for reference:

Example: Type J Flange

	Size	Flange	Bore
5J x 3/4"	5	J	3/4"
7S x 30mm	7	S	30mm

(Note: Bored-to-size flanges are furnished with standard key-way and 2 setscrews unless specified otherwise.)

Example: Type B Flange

	Size	Flange	Bushing
8B — SH	8	B	SH

(Note: The SH bushing with required bore size should be specified separately.)

Example: Sleeves

	Size	Style & Material
8JEM	8	Solid, TPR
11E	11	2 Piece, EPDM

(Note: Unless specified, TPR (3 thru 10) or EPDM (11 thru 16) will be supplied.)

Example: Complete spacer coupling

1	6EM	(6 TPR 2 Piece Sleeve)
2	6SC35	(Flanges for 3 1/2" dropout)
1	6H x 1"	(6 Spacer Hub for 1" Bore)
1	6H x 1 1/8"	(6 Spacer Hub for 1 1/8" Bore)

Sleeve Selection



QUADRA-FLEX® coupling sleeves are available in four different types of compounds. These include TPR (ThermoPlastic Rubber) in types JEM, JEMS, EM; EPDM Rubber in type E;

Neoprene in type N; Hytrel in type H and HS. To determine the sleeve best suited for the application, the material characteristics are given below.

TPR (Sizes 3-10)

QUADRA-FLEX® couplings are usually supplied with TPR sleeves in sizes 3-10. TPR is a general use sleeve which combines the characteristics of both EPDM & Neoprene into one. These sleeves operate within a temperature range from -50° F to +275° F (-46° C to +135° C). Torsional flexibility is 15°.

EPDM (Sizes 11-16)

QUADRA-FLEX® couplings are usually supplied with EPDM rubber sleeves in sizes 11-16. EPDM is a general use sleeve and can operate within a temperature range from -30° F to +275° F (-34° C to +135° C). Torsional flexibility is 15°.

NEOPRENE* (Sizes 11-16)

Neoprene flexible sleeves are also available in sizes 11-14. These sleeves offer a higher resistance than EPDM and are self-extinguishing. Operating temperature range for this sleeve is 0° F to +200° F (-18° C to +93° C). Torsional flexibility is 15°.

HYTREL* (Sizes 6-14)

Hytrel sleeves are molded specifically for high torque applications. The type H will transmit approximately four times as much power as an equivalent TPR, EPDM, or Neoprene sleeve. Hytrel has an operating temperature from 65° F to +250° F (-54° C to +121° C). Torsional flexibility is 7°.

Note: Do not use a Hytrel sleeve as a replacement for a TPR, EPDM, or Neoprene sleeve.

Sleeve Chemical Resistance

Resistance To:	TPR	EPDM	Neoprene*	Hytrel*	Resistance To:	TPR	EPDM	Neoprene*	Hytrel*
Acetone	A	A	B	B	Isopropyl	A	T	A	A
Ammonia, Anhydrous	B	T	A	N	Kerosene	B	X	B	T
Ammonium Hydroxide Solutions	T	A	A(158F)	T	Lacquer Solvents	T	...	C	B
ASTM hydrocarbon test fluid	N	C	X	A	Lubricating Oils	B	X	B(158F)	A
ASTM oil no. 1	B	C	A	A	Methyl Alcohol	A	T	A(158F)	A
ASTM oil no. 3	B	C	B(158F)	A	Mineral Oil	B	X	A	A
ASTM reference fuel A	B	C	A	A	Naphtha	B	C	C	A
ASTM reference fuel B	B	C	C	A	Nitric Acid, 10%	A	T	B	B
ASTM reference fuel C	B	X	C	B	Nitrobenzene	T	A	C	C
Benzene	C	C	C	B	Phenol	T	T	B	C
Butane	B	B	A	A	Phosphoric Acid, 20%	A	T	T	N
Carbon Tetrachloride	X	C	C	C	Phosphate Esters	A	A	C	A
Chlorobenzene	C	X	X	X	Pickling Solution (20% Nitric Acid, 4% HF)	N	X	B-C	X
Chloroform	X	C	C	C	Soap Solutions	A	T	A(158F)	A
Chromic Acid, 10-50%	T	T	C	N	Sodium Hydroxide, 20%	A	A	A	A
Dowtherm A Solvent	X	N	B	N	Stearic Acid	T	T	B(158F)	T
Ethyl Alcohol	A	A	A(158F)	A	Sulfuric Acid, up to 50%	A	T	A(158F)	A
Ethylene Glycol	A	A	A(158F)	A	Sulfuric Acid, up to 80%	A	T	B-C	C
Fuel Oil	B	X	A	A	Tannic Acid, 10%	T	T	A	T
Gasoline	B	B-C	B	A	Toluene	C	C	C	B
Glycerine	A	T	A(158F)	A	Trichloroethylene	C	X	C	C
Hydraulic Oils	B	N	A	A	Turpentine	B	C	C	N
Hydrochloric Acid, 20%	A	T	A	B	Water	A	A(158F)	A(212F)	A(158F)
Hydrogen Peroxide, 88½%	N	T	B	T	Xylene	C	C	X	B

A — Fluid has little or no effect
 B — Fluid has minor to moderate effect
 C — Fluid has severe effect

N — No evaluation has been attempted.
 T — No data; likely to be compatible
 X — No data; not likely to be compatible

*Registered Trademark of Dupont

Selection Procedure

When the driver is an electric motor with standard speed.

Step 1. Determine Service Factor (SF) Symbol based on equipment listed on page C-10.

Step 2. Determine proper Service Factor from chart at top of page C-10.

Step 3. Refer to page C-12 and C-13 for proper selection of coupling. Based on chemical resistance and operating environment found on page C-8, select from chart the type of sleeve material. Find RPM of motor, then, in the column for service factor determined in Step 2, read down to the corresponding horsepower of motor being used as the driver. The number listed is the correct coupling size.

Example: A coupling is needed to connect a 25 HP standard electric motor to a lumber log haul at 1750 RPM.

1. Service Factor Symbol — H
2. Service Factor — 2.0
3. Coupling Size — 9 with TPR sleeve or 6 with Hytrel Sleeve

Step 4. Select flanges from pages C-13 thru C-16, check coupling bore size range for proper shaft fit.

★ **NOTE: Do not oversize coupling hub — will cause premature wear of element.**

When the driver is other than an electric motor or the speeds are different than those shown in the chart on pages C-8 and C-9.

Step 1. Follow steps 1 & 2 in previous procedure.

Step 2. Calculate Horsepower at 100 RPM as follows:

$$\text{HP at 100 RPM} = \frac{\text{HP} \times \text{Service Factor} \times 100}{\text{coupling RPM}}$$

Step 3. Select coupling size from Table 2. Find a HP equal to or greater than the HP/100 RPM

Step 4. Check Maximum bore to be sure that both shaft sizes do not exceed figure listed for size selected in step 4. If maximum is exceeded select the next largest size which will allow for bore size. Do not exceed maximum RPM for new size selected.

Example: A bucket elevator is driven by a motor/reducer and requires a coupling to transmit 14 HP at 1300 RPM.

1. Service Factor Symbol — M
2. Service Factor — 1.5
3. HP at 100 RPM = $\frac{14 \times 1.5 \times 100}{1300} = 1.61 \text{ HP/100 RPM}$
4. Refer to page C-11; under column for 100 RPM the required 1.61 HP falls between the size 7 (1.2) and the size 8 (1.8). Correct selection is size 8 with TPR sleeve. Check bore sizes for flanges on pages C-11 thru C-13.

Maximum RPM and Allowable Misalignment

Size	Maximum RPM	Types JEM, JEMS, EM, E and N		Types H and HS	
		Parallel	Angular	Parallel	Angular
3	9200	.010	.035	—	—
4	7600	.010	.043	—	—
5	7600	.015	.056	—	—
6	6000	.015	.070	.010	.016
7	5250	.020	.081	.012	.020
8	4500	.020	.094	.015	.025
9	3750	.025	.109	.017	.028
10	3600	.025	.128	.020	.032
11	3600	.032	.151	.022	.037
12	2800	.032	.175	.025	.042
13	2400	.040	.195	.030	.050
14	2200	.045	.242	.035	.060
16	1500	.062	.330	—	—

Note: Values shown above apply if the actual torque transmitted is more than ¼ the coupling rating. For lesser torque, reduce the above values by ½.

Service Factors For QUADRA-FLEX® Couplings

Service Factor Symbol	Electric Motor Standard Torque	Electric Motor High Torque	Turbines	Reciprocating Engines
L (LIGHT)	1.25	1.5	1.0	1.5
M (MEDIUM)	1.5	2.0	1.25	2.0
H (HEAVY)	2.0	2.5	1.5	2.5

Table 1

Application	SF Symbols	Application	SF Symbols	Application	SF Symbols
AGITATORS - Paddle, Propeller, Screw	L	DISC FEEDER	L	MILLS	
BAND RESAW	M	DOUGH MIXER	M	Ball, Pebble, Rod, Tube	H
BARGE HAUL PULLER	H	DRAW BENCH CONVEYOR & Main Drive	H	Rubber, Tumbling	H
BARKING (Lumber)	H	DREDGES		Dryer and Cooler	M
BAR SCREEN (sewage)	L	Cable Reel, Pumps	M	MIXER	
BATCHES (textile)	L	Cutter Head Drive, Jig Drive	H	Concrete, Muller	M
BEATER AND PULPER (paper)	M	Screen Drive	H	Banbury	H
BENDING ROLL (metal)	M	Maneuvering and Utility Winch	M	ORE CRUSHER	H
BLEACHER (paper)	L	Stacker	M	OVEN CONVEYOR	L
BLOWERS		DYNAMOMETER	L	PLANER (metal or wood)	M
Centrifugal, Vane	L	DRYERS (rotary)	M	PRESSES	
Lobe	M	EDGER (lumber)	H	Brick, Briquette Machine	H
BOTTLING MACHINERY	L	ELEVATORS		Notching, Paper, Punch, Printing	M
BREW KETTLES (distilling)	L	Bucket	M	PUG MILL	M
BUCKET ELEVATOR OR CONVEYOR	M	Escalator	L	PULP GRINDER (paper)	H
CALENDERS		Freight, Passenger, Service, Man Lift	H	PULVERIZERS	
Calender (paper)	M	ESCALATORS	L	Hammermill — light duty, Roller	M
Calender-super (paper, rubber)	H	EXTRUDER (metal)	H	Hammermill — heavy duty, Hog	H
CANE KNIVES (sugar)	M	FANS		PUMPS	
CARD MACHINE (textile)	H	Centrifugal	L	Centrifugal, Axial	L
CAR DUMPERS	H	Cooling Tower	H	Gear, Lobe, Vane	M
CEMENT KILN	H	Forced Draft, Large Industrial, Mine	M	Reciprocating — sgl. or dbl. acting	*
CENTRIFUGAL BLOWERS		FEEDERS		REEL, REWINDER (paper) CABLE	M
COMPRESSORS, FANS or PUMPS	L	Apron, Belt, Disc	L	ROD MILL	H
CHEMICAL FEEDERS (sewage)	L	Reciprocating	H	SAWDUST CONVEYOR	L
CHILLER (oil)	M	Screw	M	SCREENS	
CHIPPER (paper)	H	FILTER, PRESS-OIL	M	Air Washing, Water	L
CIRCULAR RESAW	M	GENERATORS		Rotary for coal or sand	M
CLARIFIER or CLASSIFIER	L	Uniform load	L	Vibrating	H
CLAY WORKING MACHINERY	M	Varying load, Holst	M	SCREW CONVEYOR	L
COLLECTORS (sewage)	L	Welders	H	SLAB CONVEYOR (lumber)	M
COMPRESSORS		GRIT COLLECTOR (sewage)	L	SLITTERS (metal)	M
Centrifugal	L	GRIZZLY	H	SOAPERS (textile)	L
Reciprocating	*	HAMMERMILL		SORTING TABLE (lumber)	M
Screw, Lobe	L	Light Duty, Intermittent	M	SPINNER (textile)	M
CONCRETE MIXERS	M	Heavy Duty, Continuous	H	STOKER	L
CONVERTING MACHINE (paper)	M	HOISTS		SUCTION ROLL (paper)	M
CONVEYORS		Heavy Duty	H	TENTER FRAMES (textile)	M
Apron, Assembly Belt, Flight	L	Medium Duty	M	TIRE BUILDING MACHINES	H
Oven, Screw	L	JORDAN (paper)	H	TIRE & TUBE PRESS OPENER	L
Bucket	M	KILN, ROTARY	H	TUMBLING BARRELS	H
COOKERS- Brewing, Distilling, Food	L	LAUNDRY WASHER or TUMBLER	H	WASHER and THICKENER (paper)	M
COOLING TOWER FANS	H	LINE SHAFTS	L	WINCHES	M
COUCH (paper)	M	LOG HAUL (lumber)	H	WINDERS, Paper, Textile, Wire	M
CRANES & HOISTS	M	LOOM (textile)	M	WINDLASS	M
Heavy Duty Mine	H	MACHINE TOOLS, MAIN DRIVE	M	WIRE	
CRUSHERS — Cane (sugar), Stone, Ore	H	MANGLE (textile)	L	Drawing	H
CUTTER — Paper	H	MASH TUBS (distilling)	L	Winding	M
CYLINDER (paper)	H	MEAT GRINDER	M	WOODWORKING MACHINERY	L
DEWATERING SCREEN (sewage)	M	METAL FORMING MACHINES	M		

* Consult Factory



Coupling Ratings

Coupling Ratings

Table 2A ThermoPlastic Rubber (TPR)

Coupling Size	Sleeve Construction	Basic HP Ratings Per Given RPM					Rated Torque (in.-lb.)	Torsional • Stiffness Factor (in.-lb./radians)	Maximum RPM
		100	860	1160	1750	3500			
3	TPR	.10	.8	1.1	1.7	3.3	60	229	9200
4	TPR	.19	1.6	2.2	3.3	6.7	120	458	7600
5	TPR	.38	3.3	4.4	6.7	13.0	240	916	7600
6	TPR	.71	6.1	8.3	12.5	25.0	450	1718	6000
7	TPR	1.20	10.0	13.0	20.0	40.0	725	2769	5250
8	TPR	1.80	16.0	20.0	32.0	63.0	1135	4335	4500
9	TPR	2.80	25.0	33.0	50.0	100.0	1800	6875	3750
10	TPR	4.60	39.0	53.0	80.0	160.0	2875	10980	3600

Table 2B EPDM & Neoprene

Coupling Size	Sleeve Construction	Basic HP Ratings Per Given RPM					Rated Torque (in.-lb.)	Torsional • Stiffness Factor (in.-lb./radians)	Maximum RPM
		100	860	1160	1750	3500			
11	EPDM & Neoprene	7.20	62.0	83.0	126.0	252.0	4530	17300	3600
12	EPDM & Neoprene	11.40	98.0	132.0	200.0	—	7200	27500	2800
13	EPDM & Neoprene	18.00	155.0	209.0	315.0	—	11350	43350	2400
14	EPDM & Neoprene	28.60	246.0	331.0	500.0	—	18000	68755	2200
16	EPDM	75.00	645.0	870.0	—	—	47250	180480	1500

Table 2C Hytrel

Coupling Size	Sleeve Construction	Basic HP Ratings Per Given RPM					Rated Torque (in.-lb.)	Torsional • Stiffness Factor (in.-lb./radians)	Maximum RPM
		100	860	1160	1750	3500			
3◄	HYTREL	—	—	—	—	—	—	—	—
4◄	HYTREL	—	—	—	—	—	—	—	—
5◄	HYTREL	—	—	—	—	—	—	—	—
6	HYTREL	2.9	25.0	33.0	50.0	100.0	1800	10000	6000
7	HYTREL	4.6	39.0	53.0	80.0	160.0	2875	20000	5250
8	HYTREL	7.2	62.0	84.0	126.0	252.0	4530	30000	4500
9	HYTREL	11.4	98.0	132.0	200.0	400.0	7200	47500	3750
10	HYTREL	18.0	155.0	209.0	315.0	630.0	11350	100000	3600
11	HYTREL	28.6	246.0	331.0	500.0	1000.0	18000	125000	3600
12	HYTREL	50.0	430.0	580.0	875.0	—	31500	225000	2800
13	HYTREL	75.0	645.0	870.0	1312.0	—	47268	368900	2400
14	HYTREL	115.0	986.0	1334.0	2013.0	—	72480	593250	2200

◄ Hytrel sleeves are available on a made-to-order basis. Consult factory.
 • Values shown are for an ambient temperature of 75° F (24° C).

Sleeve Selection Chart



Selection Chart for TPR¹, EPDM, & Neoprene Sleeves

HP	860 RPM Motor					1160 RPM Motor					1750 RPM Motor					3500 RPM Motor				
	Service Factors					Service Factors					Service Factors					Service Factors				
	1.0	1.25	1.5	2.0	2.5	1.0	1.25	1.5	2.0	2.5	1.0	1.25	1.5	2.0	2.5	1.0	1.25	1.5	2.0	2.5
1/2	3	3	3	4	4	3	3	3	4	4	3	3	3	3	3	—	—	—	—	—
3/4	3	4	4	4	5	3	3	4	4	4	3	3	3	3	4	3	3	3	3	3
1	4	4	4	5	5	3	4	4	4	5	3	3	3	4	4	3	3	3	3	3
1 1/2	4	5	5	5	6	4	4	5	5	5	3	4	4	4	5	3	3	3	3	4
2	5	5	5	6	6	4	5	5	5	6	4	4	4	5	5	3	3	3	4	4
3	5	6	6	6	7	5	5	6	6	6	4	5	5	5	6	3	4	4	4	5
5	6	6	7	7	8	6	6	6	7	7	5	5	6	6	6	4	4	5	5	5
7 1/2	7	7	8	8	9	6	7	7	8	8	6	6	6	7	7	5	5	5	6	6
10	7	8	8	9	9	7	7	8	8	9	6	6	7	7	8	5	5	6	6	6
15	8	9	9	10	10	8	8	9	9	10	7	7	8	8	9	6	6	6	7	7
20	9	9	10	10	11	8	9	9	10	10	7	8	8	9	9	6	6	7	7	8
25	9	10	10	11	11	9	9	10	10	11	8	8	9	9	10	6	7	7	8	8
30	10	10	11	11	12	9	10	10	11	11	8	9	9	10	10	7	7	8	8	9
40	10	11	11	12	12	10	10	11	11	12	9	9	10	10	11	7	8	8	9	9
50	11	11	12	12	13	10	11	11	12	12	9	10	10	11	11	8	8	9	9	10
60	11	12	12	13	13	11	11	12	12	13	10	10	11	11	12	8	9	9	10	10
75	12	12	13	13	14	11	12	12	13	13	10	11	11	12	12	9	9	10	10	11
100	12	13	13	14	14	12	12	13	13	14	11	11	12	12	13	9	10	10	11	11
125	13	13	14	14	—	12	13	13	14	14	11	12	12	13	13	10	10	11	11	—
150	13	14	14	16	16	13	13	14	14	16	12	12	13	13	14	10	11	11	—	—
200	14	14	16	16	16	13	14	14	16	16	12	13	13	14	14	11	11	—	—	—
250	14	16	16	16	16	14	14	16	16	16	13	13	14	14	—	11	—	—	—	—
300	16	16	16	16	—	14	16	16	16	16	13	14	14	—	—	—	—	—	—	—
350	16	16	16	—	—	16	16	16	16	16	14	14	—	—	—	—	—	—	—	—
400	16	16	16	—	—	16	16	16	16	—	14	14	—	—	—	—	—	—	—	—
450	16	16	—	—	—	16	16	16	—	—	14	—	—	—	—	—	—	—	—	—
500	16	16	—	—	—	16	16	16	—	—	14	—	—	—	—	—	—	—	—	—
600	16	—	—	—	—	16	16	—	—	—	—	—	—	—	—	—	—	—	—	—
700	—	—	—	—	—	16	16	—	—	—	—	—	—	—	—	—	—	—	—	—
800	—	—	—	—	—	16	—	—	—	—	—	—	—	—	—	—	—	—	—	—

¹ ThermoPlastic Rubber

Caution: Applications involving reciprocating engines and reciprocating driven devices are subject to critical rotational speeds which may damage the coupling and/or connected equipment. Contact factory with specific requirements.



Hytrell Selection Chart

Selection Chart for Hytrell Sleeves

HP	860 RPM Motor					1160 RPM Motor					1750 RPM Motor					3500 RPM Motor									
	Service Factors					Service Factors					Service Factors					Service Factors									
	1.0	1.25	1.5	2.0	2.5	1.0	1.25	1.5	2.0	2.5	1.0	1.25	1.5	2.0	2.5	1.0	1.25	1.5	2.0	2.5					
1																									
1½																									
2																									
3																									
5																									
7½	6H	6H	6H	6H	6H	—	—	—	—	—	—	—	—	—	—	—	—	—	—	—	—	—	—	—	
10	6H	6H	6H	6H	6H	6H	6H	6H	6H	6H	—	—	—	—	—	—	—	—	—	—	—	—	—	—	
15	6H	6H	6H	7H	7H	6H	6H	6H	7H	7H	6H	6H	6H	6H	6H	6H	—	—	—	—	—	—	—	—	
20	6H	6H	7H	7H	8H	6H	6H	6H	7H	7H	6H	6H	6H	6H	6H	6H	—	—	—	—	—	—	—	—	
25	6H	7H	7H	8H	8H	6H	6H	7H	7H	8H	6H	6H	6H	6H	7H	—	—	—	—	—	—	—	—	—	
30	7H	7H	8H	8H	9H	6H	7H	7H	8H	8H	6H	6H	6H	7H	7H	6H	6H	6H	6H	6H	6H	6H	6H	6H	
40	7H	8H	8H	9H	9H	7H	7H	8H	8H	9H	6H	6H	7H	7H	8H	6H	6H	6H	6H	6H	6H	6H	6H	6H	
50	8H	8H	9H	9H	10H	7H	8H	8H	9H	9H	6H	7H	7H	8H	8H	6H	6H	6H	6H	6H	6H	6H	7H	7H	
60	8H	9H	9H	10H	10H	8H	8H	9H	9H	10H	7H	7H	8H	8H	9H	6H	6H	6H	6H	7H	7H	7H	7H	7H	
75	9H	9H	10H	10H	11H	8H	9H	9H	10H	10H	7H	8H	8H	9H	9H	6H	6H	7H	7H	8H	8H	8H	8H	8H	
100	9H	10H	10H	11H	11H	9H	9H	10H	10H	11H	8H	8H	9H	9H	10H	6H	7H	7H	8H	8H	8H	8H	8H	8H	
125	10H	10H	11H	11H	12H	9H	10H	10H	11H	11H	8H	9H	9H	10H	10H	7H	7H	8H	8H	9H	9H	9H	9H	9H	
150	10H	11H	11H	12H	12H	10H	10H	11H	11H	12H	9H	9H	10H	10H	11H	7H	8H	8H	9H	9H	9H	9H	9H	9H	
200	11H	11H	12H	12H	13H	10H	11H	11H	12H	12H	9H	10H	10H	11H	11H	8H	8H	9H	9H	10H	10H	10H	10H	10H	
250	11H	12H	12H	13H	13H	11H	11H	12H	12H	13H	10H	10H	11H	11H	12H	8H	9H	9H	10H	10H	10H	10H	10H	10H	
300	12H	12H	13H	13H	14H	11H	12H	12H	13H	13H	10H	11H	11H	12H	12H	9H	9H	10H	10H	11H	11H	11H	11H	11H	
350	12H	12H	13H	14H	14H	12H	12H	12H	13H	14H	11H	11H	12H	12H	12H	9H	10H	10H	11H	11H	11H	11H	11H	11H	
400	12H	13H	13H	14H	14H	12H	12H	13H	13H	14H	11H	11H	12H	12H	13H	9H	10H	10H	11H	11H	11H	11H	11H	11H	
500	13H	13H	14H	14H	—	12H	13H	13H	14H	14H	11H	12H	12H	13H	13H	10H	10H	11H	11H	—	—	—	—	—	
600	13H	14H	14H	—	—	13H	13H	13H	14H	—	12H	12H	13H	13H	14H	10H	11H	11H	—	—	—	—	—	—	
700	14H	14H	—	—	—	13H	13H	14H	14H	—	12H	12H	13H	14H	14H	11H	11H	—	—	—	—	—	—	—	
800	14H	14H	—	—	—	13H	14H	14H	—	—	12H	13H	13H	14H	14H	11H	11H	—	—	—	—	—	—	—	
900	14H	—	—	—	—	14H	14H	14H	—	—	13H	13H	14H	14H	—	11H	—	—	—	—	—	—	—	—	
1000	—	—	—	—	—	14H	14H	—	—	—	13H	13H	14H	14H	—	11H	—	—	—	—	—	—	—	—	

QUADRA-FLEX® Sleeves

Martin flexible sleeve elements are offered in four material compounds (ThermoPlastic Rubber (TPR), EPDM, Neoprene, and Hytrel) available in three construction styles. Our EM sleeve offers the combination of EPDM's extended temperature range as well as the higher oil resistance which Neoprene provides.

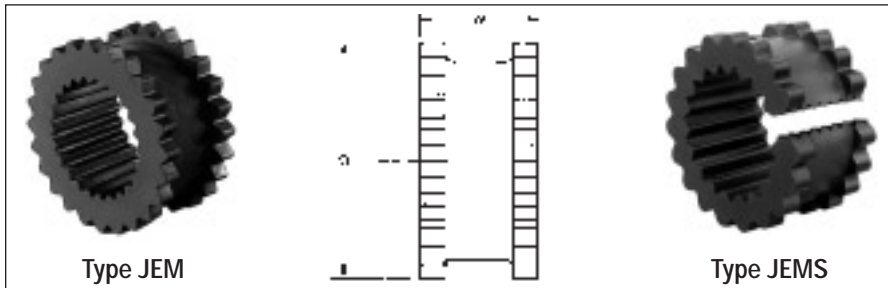

Type JEM

Type JEMS

Types JEM — JEMS

Type J sleeves are molded ThermoPlastic Rubber (TPR). Available in 1 piece solid (JEM), and 1 piece split, construction (JEMS). TPR material will handle higher temperature ranges as well as be oil resistant.

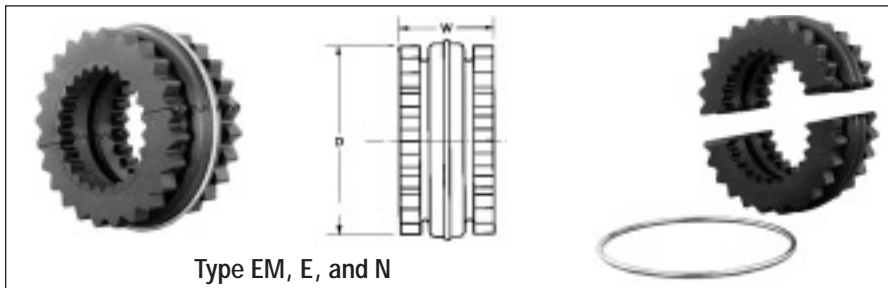

Type EM, E, and N

Types EM — E — N

Type EM, E, and N sleeves are of two piece molded construction with Retaining Ring. They are available in ThermoPlastic Rubber (Type TPR), EPDM (Type E), or Neoprene (Type N). These can be used with any type flanges within a given size range.

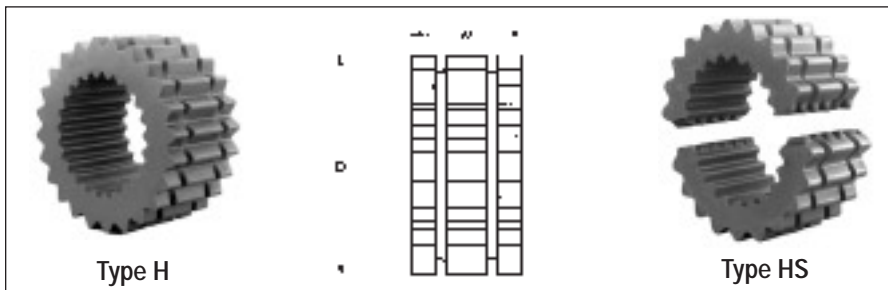

Type H

Type HS

Types H & HS

Martin H & HS sleeves are molded Hytrel for higher torque loading than standard EM sleeves. H & HS sleeves cannot be used with style J and B flanges. Hytrel sleeves are not a direct replacement for TPR, EPDM, or Neoprene sleeves.

Dimensions (Inches)

Coupling Size	JEM — JEMS Sleeves			EM Sleeves			E and N Sleeves EPDM and Hytrel			H & HS Sleeves Hytrel*		
	D	W	Wt. (lb.)	D	W	Wt. (lb.)	D	W	Wt. (lb.)	D	W	Wt. (lb.)
3	1 1/4	1	.06	—	—	—	—	—	—	—	—	—
4	2 5/16	1 1/4	.10	2 5/16	1 1/4	.11	—	—	—	—	—	—
5	2 5/8	1 5/8	.20	2 5/8	1 5/8	.25	—	—	—	—	—	—
6	3 3/8	1 3/4	.40	3 3/8	1 3/4	.49	—	—	—	3 3/8	1 3/4	.44
7	4 1/2	2 3/8	.62	4 1/2	2 3/8	.77	—	—	—	4 1/2	2 3/8	.69
8	5 1/8	2 1/2	1.13	5 1/8	2 1/2	1.4	—	—	—	5 1/8	2 1/2	1.4
9	6	3	1.46	6	3	2.0	—	—	—	6	3	1.8
10	7 1/8	3 1/8	2.32	7 1/8	3 1/8	3.2	—	—	—	7 1/8	3 1/8	2.9
11	—	—	—	—	—	—	8 3/8	4	5.1	8 3/8	4	4.5
12	—	—	—	—	—	—	9 1/8	4 1/8	8.1	9 1/8	4 1/8	7.3
13	—	—	—	—	—	—	11 3/8	5 1/2	13.0	11 3/8	5 1/2	11.8
14	—	—	—	—	—	—	13 3/2	6 1/2	21.1	13 3/2	6 1/2	19.3
16	—	—	—	—	—	—	17 3/2	8 3/4	45.3	—	—	—

* 13 & 14 Hytrel available with HS sleeves only.

QUADRA-FLEX® Type J Flanges

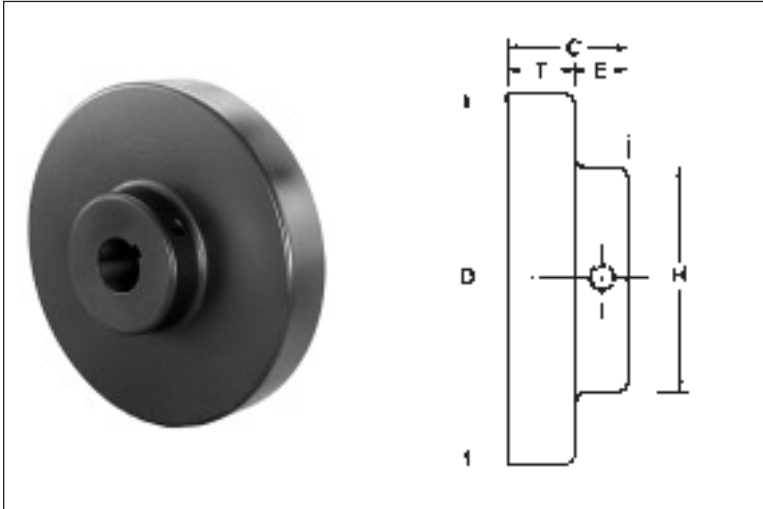

QUADRA-FLEX® Type J Flanges

Martin Type J Flanges are supplied bored to size with standard keyway and two setscrews to slip fit on standard shafting.

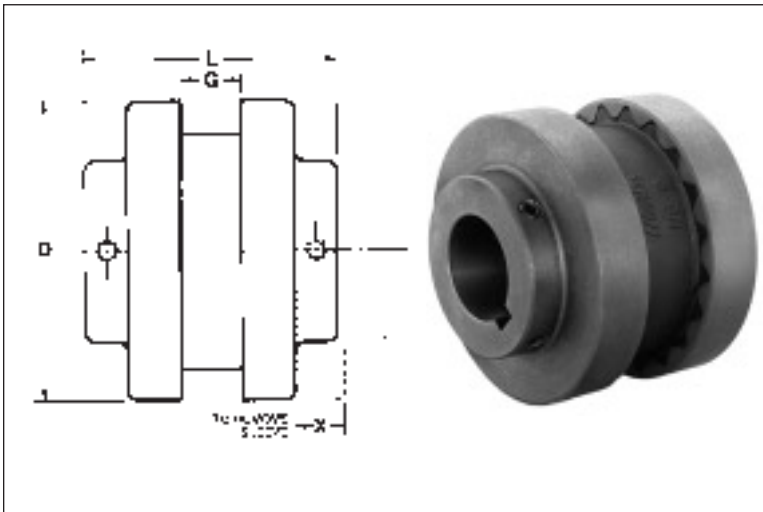

Type J Flanges use the Martin JEM 1 Piece, the Martin JEMS 1 piece split and the Martin EM 2 piece split sleeves.

(Note: Hytrel sleeves are not intended for use with this type of flange.)

Dimensions (Inches)

Coupling Size	Dimensions								Weight (lbs.)★	Finished Bore Sizes* (Inches)	Max. Bore	Millimeters
	C	D	E	G	H	L	T	X				
3J	$\frac{1}{8}$	2.062	$\frac{1}{16}$	$\frac{3}{8}$	$1\frac{1}{4}$	2	$\frac{3}{8}$	$\frac{9}{16}$.26	$\frac{3}{8}$ ** - $\frac{1}{2}$ - $\frac{5}{8}$ - $\frac{3}{4}$	$\frac{3}{4}$	— — —
	$\frac{1}{4}$	2.062	$\frac{1}{16}$	$\frac{3}{8}$	$1\frac{1}{2}$	2	$\frac{3}{8}$	$\frac{9}{16}$.26	$\frac{7}{8}$	$\frac{7}{8}$	— — —
4J	$\frac{3}{8}$	2.460	$\frac{1}{16}$	$\frac{3}{8}$	$1\frac{1}{8}$	$2\frac{1}{8}$	$\frac{7}{16}$	$\frac{3}{4}$.47	$\frac{1}{2}$ - $\frac{5}{8}$ - $\frac{3}{4}$ - $\frac{7}{8}$ - $\frac{15}{16}$ - 1	1	15 20 25
5J	$1\frac{1}{16}$	3.250	$\frac{15}{32}$	$\frac{3}{4}$	$1\frac{1}{8}$	$2\frac{1}{8}$	$\frac{19}{32}$	$\frac{31}{32}$.86	$\frac{1}{2}$ - $\frac{5}{8}$ - $\frac{3}{4}$ - $\frac{7}{8}$ - $\frac{15}{16}$ - 1 - $1\frac{1}{8}$	$1\frac{1}{8}$	— — —
6J	$1\frac{1}{32}$	4.000	$\frac{19}{32}$	$\frac{7}{8}$	$1\frac{15}{16}$	$3\frac{5}{16}$	$\frac{5}{8}$	$1\frac{13}{32}$	1.73	$\frac{5}{8}$ - $\frac{3}{4}$ - $\frac{7}{8}$ - $\frac{15}{16}$ - 1	—	— — —
	$1\frac{1}{2}$	4.000	$\frac{19}{32}$	$\frac{7}{8}$	$2\frac{1}{2}$	$3\frac{1}{16}$	$\frac{5}{8}$	$1\frac{15}{32}$	1.70	$1\frac{1}{8}$ - $1\frac{1}{16}$ - $1\frac{1}{4}$ - $1\frac{1}{2}$	$1\frac{1}{8}$	— — —

* Approximate weight for each flange.

** $\frac{3}{8}$ " Bore has no Keyway

• J flanges can be rebored if necessary.

Type S Flanges



QUADRA-FLEX® Type S Couplings (Bored to Size)

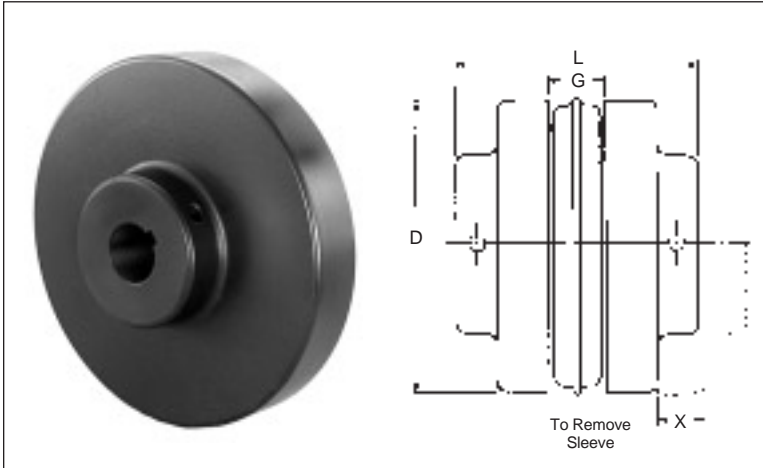

Type S flexible coupling flanges are bored to size to fit on any standard shaft. They are produced from high strength cast iron. Units are easy to install and remove and are stocked in a wide range of bore sizes as shown on the next page.

Dimensions

Coupling Size	Flange Diameter (D)	Bore (Inches)			Hub (Inches)			G	L	T	X	Weight (Lbs.)•
		Stock	Rec. Max. ★	Rec. Max. ★★	Hub Diameter (H)	Length Thru (C)	Hub Proj. (E)					
5S	3.250	½	1⅞	1¼	1½	1½	1½	¾	2⅞	⅞	¾	1.0
6S	4.000	¾	1⅞	1½	2½	1½	⅞	⅞	3½	⅞	1½	2.1
	4.000	¾	—	1¾	2½	1½	⅞	⅞	3½	⅞	1½	2.1
	4.000	¾	—	1½	2⅞	1½	⅞	⅞	4	⅞	1½	2.1
7S	4.625	¾	1¾	1½	2⅞	1½	⅞	1	3⅞	⅞	1½	2.7
8S	5.450	¾	1⅞	2¼	3¼	2½	¾	1½	4⅞	⅞	1½	4.5
	5.450	¾	—	2¾	3¼	1⅞	1½	1½	5	⅞	1½	4.5
9S	6.350	¾	2¾	2½	3¾	2½	⅞	1½	5⅞	1½	1¾	6.5
	6.350	¾	—	2¾	4¾	2½	1¼	1½	6	1½	1¾	6.5
10S	7.500	1½	2¾	3¾	4¾	2⅞	⅞	1½	5⅞	1½	2	11.3
	7.500	1½	—	3¾	4¾	2⅞	1½	1½	7	1½	2	11.3
11S	8.625	1¼	2¼	—	3¾	3⅞	1½	1½	7¾	1½	2¾	17.6
	8.625	1¼	2¼	—	4¾	3⅞	1½	1½	7¾	1½	2¾	17.6
	8.625	1¼	3¾	3¾	5¼	3⅞	1½	1½	7¾	1½	2¾	17.6
	8.625	1¼	—	3¾	5¾	3⅞	1⅞	1½	8	1½	2¾	17.6
12S	10.000	1½	2¼	—	3¾	4	⅞	2⅞	8¾	1⅞	2⅞	27.2
	10.000	1½	2¼	—	4¾	4	⅞	2⅞	8¾	1⅞	2⅞	27.2
	10.000	1½	3¾	3⅞	5¾	4	⅞	2⅞	8¾	1⅞	2⅞	27.2
13S	11.750	2	2¾	—	4¾	4¾	1½	2⅞	9¾	1⅞	3⅞	45.6
	11.750	2	4¾	—	6¾	4¾	1½	2⅞	9¾	1⅞	3⅞	45.6
14S	13.875	2	2¾	—	4¾	4¾	1½	3¼	9¾	2¼	3¾	70.0
	13.875	2	5	—	7¾	4¾	1½	3¼	9¾	2¼	3¾	70.0
16S	18.875	2	5¾	6	8	6	2	4¾	14¾	2¾	4¾	126.0

★ Recommended max. bore with standard keyway.

★★ Recommended max. bore with shallow keyway. See chart on page C-14 for recommended keyway size.

• Approximate weight for each flange.



Type S Flanges

Type S QUADRA-FLEX® Couplings Finished Bore Sizes

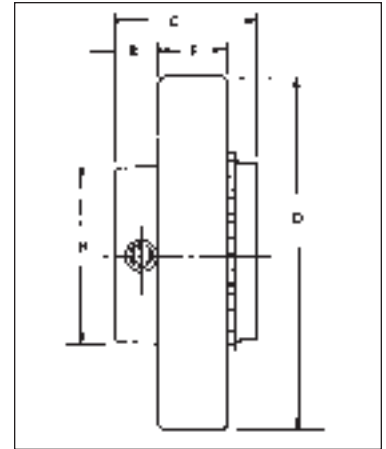

Millimeter

Coupling Size	Finished Bore Sizes										
	Millimeter										
5S	15	20	25								
6S		20	25	28	30		35				
7S			25	28	30			38	42		
8S				28	30	32		38	42	45	48
9S					30	32		38	42		48

Inches

Coupling Size	Finished Bore Sizes																
	Inches																
5S	$\frac{5}{8}$	$\frac{3}{4}$	$\frac{13}{16}$	$\frac{1}{2}$	$\frac{5}{8}$	1	$1\frac{1}{16}$	$1\frac{1}{8}$	$1\frac{1}{4}$	$1\frac{3}{8}$	$1\frac{1}{2}$						
6S	$\frac{3}{4}$	$\frac{7}{8}$	$\frac{15}{16}$	1	$1\frac{1}{16}$	$1\frac{1}{8}$	$1\frac{1}{4}$	$1\frac{1}{2}$	$1\frac{3}{8}$	$1\frac{1}{2}$	$1\frac{5}{8}$	$1\frac{3}{4}$	$1\frac{7}{8}$	$1\frac{1}{2}$			
7S	$\frac{3}{4}$	$\frac{7}{8}$	$\frac{15}{16}$	1	$1\frac{1}{16}$	$1\frac{1}{8}$	$1\frac{1}{4}$	$1\frac{1}{2}$	$1\frac{3}{8}$	$1\frac{1}{2}$	$1\frac{5}{8}$	$1\frac{3}{4}$	$1\frac{7}{8}$	$1\frac{1}{2}$	$1\frac{5}{8}$	$1\frac{3}{4}$	$1\frac{7}{8}$
8S	$\frac{7}{8}$	$\frac{15}{16}$	1	$1\frac{1}{16}$	$1\frac{1}{8}$	$1\frac{1}{4}$	$1\frac{1}{2}$	$1\frac{3}{8}$	$1\frac{1}{2}$	$1\frac{5}{8}$	$1\frac{3}{4}$	$1\frac{7}{8}$	$1\frac{1}{2}$	$1\frac{5}{8}$	$1\frac{3}{4}$	$1\frac{7}{8}$	$2\frac{1}{8}$
9S	1	$1\frac{1}{8}$	$1\frac{1}{4}$	$1\frac{1}{2}$	$1\frac{3}{8}$	$1\frac{1}{2}$	$1\frac{5}{8}$	$1\frac{3}{4}$	$1\frac{7}{8}$	$1\frac{1}{2}$	$1\frac{5}{8}$	$1\frac{3}{4}$	$1\frac{7}{8}$	$2\frac{1}{8}$	$2\frac{1}{4}$	$2\frac{1}{2}$	$2\frac{3}{8}$
10S	$1\frac{1}{8}$	$1\frac{1}{4}$	$1\frac{1}{2}$	$1\frac{3}{8}$	$1\frac{1}{2}$	$1\frac{5}{8}$	$1\frac{3}{4}$	$1\frac{7}{8}$	$1\frac{1}{2}$	$1\frac{5}{8}$	2	$2\frac{1}{8}$	$2\frac{1}{4}$	$2\frac{3}{8}$	$2\frac{1}{2}$	$2\frac{5}{8}$	$2\frac{3}{4}$
11S	$1\frac{1}{4}$	$1\frac{1}{2}$	$1\frac{3}{4}$	$1\frac{1}{2}$	$2\frac{1}{8}$												
12S	$1\frac{1}{2}$	$2\frac{1}{8}$															
13S	$2\frac{1}{8}$	$2\frac{1}{4}$															
14S	$2\frac{1}{4}$																
16S																	

o Plain bore only.

Keyseat Dimensions

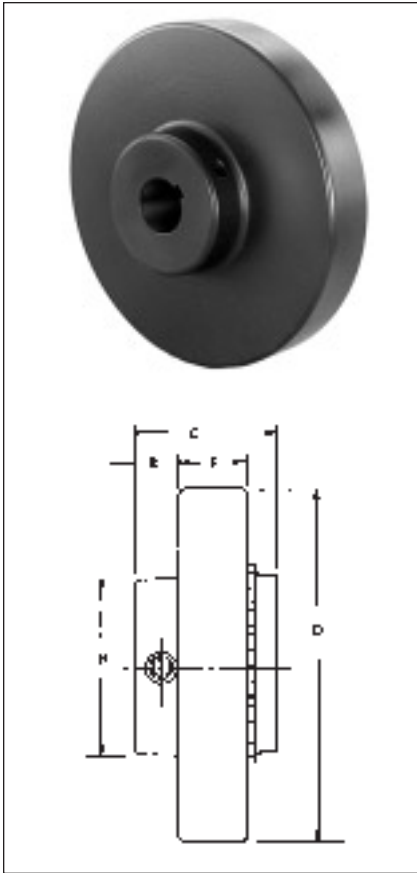

Standard Keyway Dimensions

Shaft Diameter	Width	Depth
1/2-3/8	3/8	1/16
3/8-1/2	1/2	3/32
1/2-1 1/4	3/4	1/8
1 1/8-1 1/2	1	5/32
1 1/2-2 1/4	1 1/4	3/16
2 1/8-2 3/4	1 3/4	1/4
2 3/8-3 1/4	2	5/16
3 1/8-3 3/4	2 1/4	3/8
3 3/8-4 1/2	2 3/4	7/16
4 1/8-5 1/2	3 1/4	1/2
5 1/8-6 1/2	4	5/8
	4 1/2	3/4

Bore Tolerances for Types J and S Flanges, SC Hubs

Bore (Inch)	Tolerance (Inch)
UP to 1	+0.0000 to +0.0010
1 1/8 to 2 1/8	+0.0000 to +0.0015
2 3/8 to 2 3/4	+0.0000 to +0.0020
2 11/16 to 3 11/16	+0.0000 to +0.0025
3 3/8 to 4 3/8	+0.0000 to +0.0030
4 13/16 to 6	+0.0000 to +0.0035

These bores provide a slip fit.

Shallow Keyseat Dimensions

Coupling Size	Hub Dia. (H)	Length Thru (C)	Shallow Keyseat Dimensions								
			Bore	Keyway	Key	Bore	Keyway	Key	Bore	Keyway	Key
6S	2 1/2 2 3/16	1 3/8 1 1/8	1 5/8	3/8 x 1/8 3/8 x 1/8	3/8 x 7/16 x 1 1/4	1 3/4	3/8 x 1/8	3/8 x 1/4 x 1 1/4	1 7/8	1/2 x 1/16	1/2 x 5/16 x 1 1/2
7S	2 13/16	1 23/32	1 7/8	1/2 x 1/8	1/2 x 3/8 x 1 13/16						
8S	3 1/4	2 1/8	2 1/8	1/2 x 3/16	1/2 x 7/16 x 2 1/8	2 3/8	5/8 x 1/8	5/8 x 7/16 x 1 15/16			
8S	3 1/4	1 15/16	2 1/8	1/2 x 3/16	1/2 x 7/16 x 2 1/8	2 3/8	5/8 x 1/8	5/8 x 7/16 x 1 15/16			
9S	3 3/8	2 13/32	2 1/2	5/8 x 3/16	5/8 x 3/8 x 2 1/2	2 7/8	3/4 x 1/8	3/4 x 1/2 x 2 1/8			
9S	4 1/8	2 1/2	2 1/2	5/8 x 3/16	5/8 x 3/8 x 2 1/2	2 7/8	3/4 x 1/8	3/4 x 1/2 x 2 1/8			
10S	4 3/8	2 21/32	2 7/8	3/4 x 1/4	3/4 x 5/8 x 2 11/16	3 3/8	7/8 x 3/16	7/8 x 3/8 x 2 11/16			
10S	4 3/8	2 11/16	2 7/8	3/4 x 1/4	3/4 x 5/8 x 2 11/16	3 3/8	7/8 x 3/16	7/8 x 3/8 x 2 11/16			
11S	3 1/4	3 1/8	3 1/8	1 x 1/4	1 x 3/4 x 3						
11S	4 1/8	3 1/8	3 1/8	1 x 1/4	1 x 3/4 x 3						
11S	5 1/8	3 1/8	3 1/8	1 x 1/4	1 x 3/4 x 3						
11S	5 3/8	3 1/8	3 1/8	1 x 1/4	1 x 3/4 x 3						
12S	3 3/8	4	3 15/16	1 x 1/4	1 x 3/4 x 3 15/16						
12S	4 1/8	4	3 15/16	1 x 1/4	1 x 3/4 x 3 15/16						
12S	5 1/8	4	3 15/16	1 x 1/4	1 x 3/4 x 3 15/16						

Type B Bushed QUADRA-FLEX®

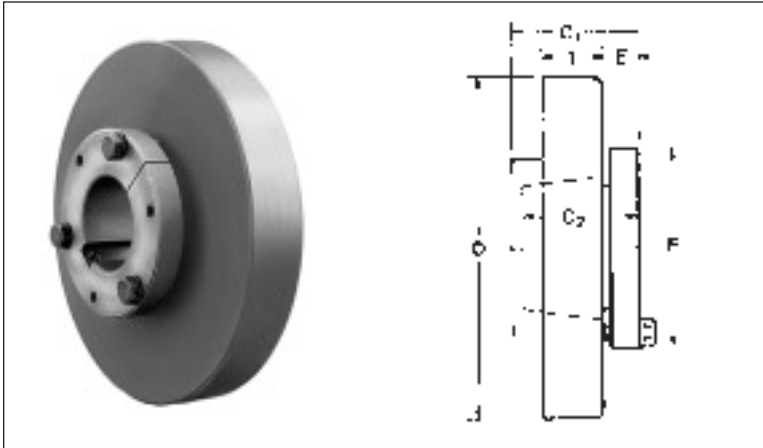

Flanges

Type B flanges are made of high quality cast iron. The same high strength cast iron used in the Type S and SC QUADRA-FLEX flanges. Type B is designed to accommodate Martin QD bushings for easy installation and removal. Type B flanges are not intended for use with Hytrel sleeves.

Coupling Size	Bushing Required	Dimensions									Max. Bore★	Weight Lbs.†	
		C ₁	C ₂	D	E	F	G	L	T	X		Flange	Bushing
6B	JA	1 ¹ / ₂	1	4.000	¹ / ₈	2	¹ / ₈	3 ¹ / ₈	²⁵ / ₃₂	1 ¹ / ₂	1 ¹ / ₈	1.7	.9
7B	JA	1 ³ / ₂	1	4.625	¹ / ₈	2	1	3 ¹ / ₈	²⁵ / ₃₂	1 ¹ / ₈	1 ¹ / ₈	2.0	1.0
8B	SH	1 ³ / ₂	1 ¹ / ₄	5.450	¹ / ₂	2 ¹ / ₈	1 ¹ / ₈	3 ¹ / ₈	²⁵ / ₃₂	1 ¹ / ₂	1 ¹ / ₈	3.1	1.0
9B	SD	2 ¹ / ₈	1 ³ / ₈	6.350	¹ / ₈	3 ¹ / ₈	1 ¹ / ₈	4 ¹ / ₈	1 ¹ / ₂	1 ³ / ₄	1 ³ / ₈	4.9	1.5
10B	SK	1 ³ / ₂	1 ¹ / ₂	7.500	⁵ / ₈	3 ¹ / ₂	1 ¹ / ₈	5 ¹ / ₈	1 ¹ / ₂	2	2 ¹ / ₂	7.0	2.0
11B	SF	2 ¹ / ₂	2	8.625	⁵ / ₈	4 ¹ / ₂	1 ¹ / ₈	6 ¹ / ₈	1 ¹ / ₂	2 ¹ / ₂	2 ¹ / ₂	11.8	3.0
12B	E	2 ¹ / ₈	2 ¹ / ₈	10.000	¹ / ₂	6	2 ¹ / ₈	7 ¹ / ₈	1 ¹ / ₈	2 ¹ / ₈	3 ¹ / ₈	17.2	10.0
13B	F	3 ¹ / ₈	3 ¹ / ₈	11.750	1	6 ¹ / ₂	2 ¹ / ₈	8 ¹ / ₈	1 ³ / ₂	3	3 ¹ / ₈	30.5	11.5
14B	F	3 ¹ / ₈	3 ¹ / ₈	13.875	1	6 ¹ / ₂	3 ¹ / ₈	9 ¹ / ₈	2 ¹ / ₄	3 ¹ / ₂	3 ¹ / ₈	51.0	11.5
16B	J	4 ¹ / ₂	4 ¹ / ₂	18.875	1 ¹ / ₈	7 ¹ / ₂	4 ¹ / ₈	12 ¹ / ₂	2 ¹ / ₄	4 ¹ / ₂	4 ¹ / ₂	120.0	18.0

★ Maximum bore with keyseat.

† Approximate weight for each flange.

QD Bushing Keyway Dimensions

Bushing	Bores	Keyseat
JA	¹ / ₂ - 1	STANDARD
	1 ¹ / ₈ - 1 ¹ / ₂	¹ / ₂ x ¹ / ₈
	1 ³ / ₈	¹ / ₂ x ¹ / ₈
	1 ¹ / ₄	NO K.S.
SH	¹ / ₂ - 1 ¹ / ₈	STANDARD
	1 ¹ / ₈ - 1 ¹ / ₂	³ / ₈ x ¹ / ₈
	1 ³ / ₈	NO K.S.
SD	¹ / ₂ - 1 ¹ / ₈	STANDARD
	1 ¹ / ₄	³ / ₈ x ¹ / ₈
	1 ³ / ₈	¹ / ₂ x ¹ / ₈
	1 ¹ / ₂ - 1 ¹ / ₈	¹ / ₂ x ¹ / ₈
	2	NO K.S.
SK	¹ / ₂ - 2 ¹ / ₈	STANDARD
	2 ¹ / ₈ - 2 ¹ / ₄	¹ / ₂ x ¹ / ₈
	2 ³ / ₈ - 2 ¹ / ₂	³ / ₈ x ¹ / ₈
	2 ⁵ / ₈ - 2 ³ / ₄	NO K.S.
	2 ⁷ / ₈ - 3	NO K.S.
SF	¹ / ₂ - 2 ¹ / ₄	STANDARD
	2 ¹ / ₈ - 2 ¹ / ₂	⁵ / ₈ x ¹ / ₈
	2 ³ / ₈ - 2 ³ / ₄	⁵ / ₈ x ¹ / ₈
	2 ⁵ / ₈ - 2 ⁷ / ₈	³ / ₄ x ¹ / ₈
	2 ⁷ / ₈	³ / ₄ x ¹ / ₂
E	¹ / ₂ - 2 ¹ / ₄	STANDARD
	2 ¹ / ₈ - 3 ¹ / ₄	¹ / ₂ x ¹ / ₈
	3 ¹ / ₈ - 3 ¹ / ₂	¹ / ₂ x ¹ / ₈
	3 ¹ / ₂	¹ / ₂ x ¹ / ₈
F	1 - 3 ¹ / ₈	STANDARD
	3 ¹ / ₈ - 3 ¹ / ₂	¹ / ₂ x ¹ / ₈
	3 ¹ / ₈ - 3 ¹⁵ / ₁₆	1x ¹ / ₈
	4	NO K.S.
J	1 ¹ / ₄ - 3 ¹ / ₄	STANDARD
	3 ¹ / ₈ - 3 ¹⁵ / ₁₆	1x ¹ / ₈
	4 - 4 ¹ / ₂	1x ¹ / ₈

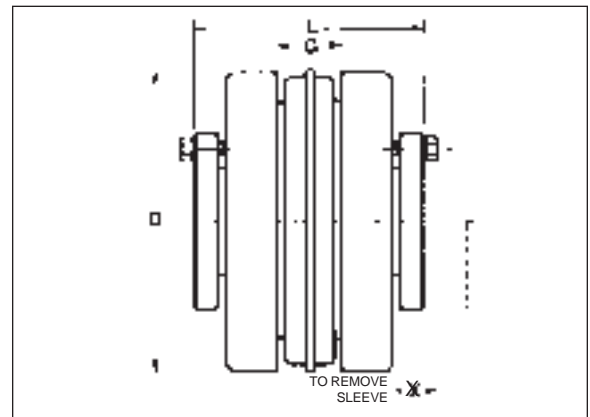

Bushings

Martin QD bushings offer convenient mounting of the flange to the shaft securely without setscrews. They are tapered and are split through both the bushing flange and taper to provide a clamp fit, eliminating wobble, vibration, and fretting corrosion. This is the same bushing used in Martin sprockets and sheaves and is readily available.

Type SC Spacer Couplings

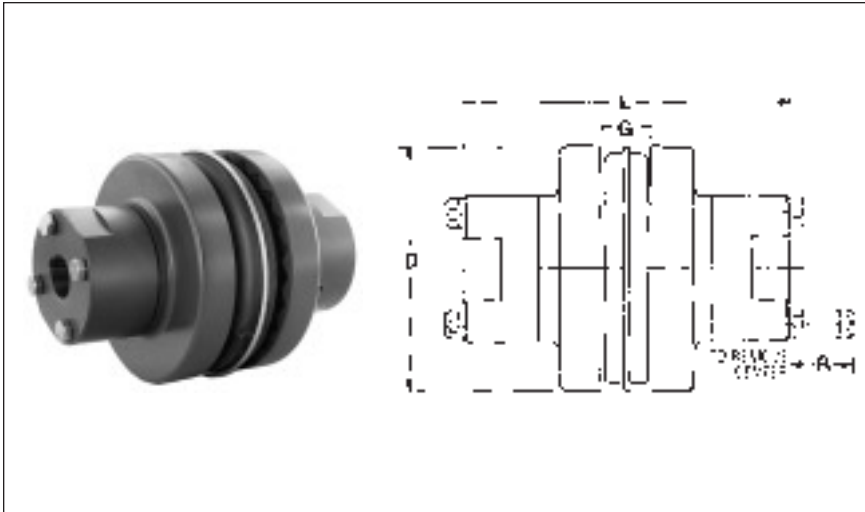

The dimensions for completely assembled QUADRA-FLEX® Type SC Spacer Couplings are shown below. See next page for dimensions of separate components.

Coupling Size	Required Distance Between Shafts	Use Flange Number	Use Hub Number	Max. Bore Standard Keyway	Dimensions				Weight ² (Lbs.) [*]
					D	L ²	G	R	
4JSC	3½	4JSC35	4H	1½	2.460	5%	¾	½	4.7
5SC	3½	5SC35	5H	1½	3.250	5%	¾	⅝	4.1
6SC	3½	6SC35	6H	1½	4.000	5%	¾	¾	7.1
6SC	4%	6SC44	6H	1½	4.000	6%	¾	¾	7.9
6SC	5	6SC50	6H	1½	4.000	7%	¾	¾	8.5
7SC	3½	7SC35	7H	1½	4.625	6%	1	¾	9.1
7SC	4%	7SC44	7H	1½	4.625	7%	1	¾	10.1
7SC	5	7SC50	7H	1½	4.625	7%	1	¾	10.7
8SC	3½	8SC35	8H	1½	5.450	6%	1½	⅞	14.7
8SC	3½	8SC35-10	10H★	2%	5.450	8%	1½	⅞	22.7
8SC	4%	8SC44	8H	1½	5.450	7%	1½	⅞	16.1
8SC	5	8SC50	8H	1½	5.450	8%	1½	⅞	15.9
8SC	5	8SC50-10	10H★	2%	5.450	9%	1½	⅞	26.5
9SC	3½	9SC35	9H★	2%	6.350	7½	1½	1½	22.0
9SC	4%	9SC44	9H★	2%	6.350	8%	1½	1½	23.4
9SC	5	9SC50	9H★	2%	6.350	8%	1½	1½	24.6
9SC	5	9SC50-11	11H★	2%	6.350	10%	1½	1½	40.2
9SC	7	9SC70-11	11H★	2%	6.350	12%	1½	1½	48.2
9SC	7½	9SC78-11	11H★	2%	6.350	13%	1½	1½	50.8
10SC	4%	10SC48	10H★	2%	7.500	9%	1½	1½	35.4
10SC	5	10SC50	10H★	2%	7.500	9%	1½	1½	38.2
10SC	7	10SC70-13	13H★	3%	7.500	13%	1½	1½	71.8
10SC	7½	10SC78-13	13H★	3%	7.500	14%	1½	1½	75.6
10SC	10	10SC100-13	13H★	3%	7.500	16%	1½	1½	89.0
11SC	4%	11 SC48	11H★	2%	8.625	10%	1½	1½	54.5
11SC	5	11 SC50	11H★	2%	8.625	10%	1½	1½	54.8
11SC	7	11SC70-14	14H	3%	8.625	14%	1½	2	85.7
11SC	7½	11SC78-14	14H	3%	8.625	15%	1½	2	90.1
11SC	10	11SC100-14	14H	3%	8.625	17%	1½	2	102.5
12SC	7	12SC70	12H★	2%	10.000	12%	2½	1½	87.7
12SC	7	12SC70-14	14H	3%	10.000	14%	2½	2	98.9
12SC	7½	12SC78	12H★	2%	10.000	13%	2½	1½	91.5
12SC	7½	12SC78-14	14H	3%	10.000	15%	2½	2	103.3
12SC	10	12SC100-14	14H	3%	10.000	17%	2½	2	115.5
13SC	7½	13SC78	13H★	3%	11.750	14%	2½	1½	121.8
14SC	7½	14SC78	14H	3%	13.875	15%	3¼	2	179.4

★ Short (HS) hub also available.
 • Approximate weight for completely assembled spacer coupling.
 1 4JSC35 x 1½ has a shallow keyway.
 2 "L" dimension and weight will change if one or two short (HS) hubs are used.
 NOTE: Refer to page C-22 to order — specify components separately.

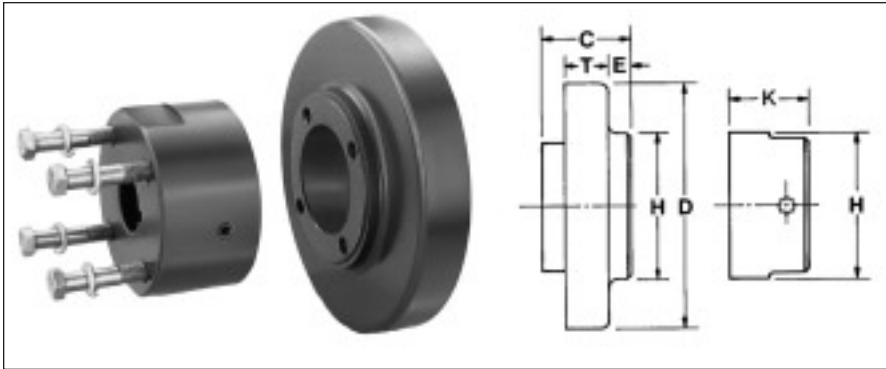

Type SC Flanges and Hubs

Tables below provide dimensional information for QUADRA-FLEX® Flanges and Hubs used for Spacer Couplings. Assembled dimensions are listed on opposite page. Any of the sleeves shown on page C-14 can be used.

Coupling Size	Flange Number	For Distance Between Shafts★	For Hub	Dimensions					Weight (Lbs.)•
				D	E	H	C	T	
4JSC	4SC35	3½	4H	2.460	⅞	2	⅞	⅞	1.2
5SC	5SC35	3½	5H	3.250	⅝	2	1⅞	⅞	1.2
6SC	6SC35	3½	6H	4.000	⅞	2½	1⅞	⅞	2.0
	6SC44	4½	6H	4.000	1⅞	2½	2⅞	⅞	2.4
	6SC50	5	6H	4.000	1⅞	2½	2⅞	⅞	2.7
7SC	7SC35	3½	7H	4.625	⅞	2⅞	1⅞	⅞	2.3
	7SC44	4½	7H	4.625	⅞	2⅞	2⅞	⅞	2.8
	7SC50	5	7H	4.625	1⅞	2⅞	2⅞	⅞	3.1
8SC	8SC35	3½	8H	5.450	⅞	3¼	1⅞	⅞	3.5
	8SC35-10	3½	10H-10HS	5.450	⅞	4⅞	1⅞	⅞	3.4
	8SC44	4½	8H	5.450	⅞	3¼	2⅞	⅞	4.2
	8SC50	5	8H	5.450	1⅞	3¼	2⅞	⅞	4.6
	8SC50-10	5	10H-10HS	5.450	1⅞	4⅞	2⅞	⅞	5.3
9SC	9SC35	3½	9H-9HS	6.350	⅞	3⅞	1⅞	1⅞	5.1
	9SC44	4½	9H-9HS	6.350	⅞	3⅞	2⅞	1⅞	5.8
	9SC50	5	9H-9HS	6.350	⅞	3⅞	2⅞	1⅞	6.4
	9SC50-11	5	11H-11HS	6.350	⅞	5¼	2⅞	1⅞	6.9
	9SC70-11	7	11H-11HS	6.350	1⅞	5¼	3⅞	1⅞	10.9
9SC78-11	7½	11H-11HS	6.350	2⅞	5¼	3⅞	1⅞	12.1	
10SC	10SC48	4½	10H-10HS	7.500	1⅞	4⅞	2⅞	1⅞	9.8
	10SC50	5	10H-10HS	7.500	⅞	4⅞	2⅞	1⅞	10.1
	10SC70-13	7	13H-13HS	7.500	1⅞	6⅞	3⅞	1⅞	14.5
	10SC78-13	7½	13H-13HS	7.500	1⅞	6⅞	3⅞	1⅞	16.3
	10SC100-13	10	13H-13HS	7.500	2⅞	6⅞	4⅞	1⅞	22.5
11SC	11SC48	4½	11H-11HS	8.625	⅞	5¼	1⅞	1⅞	12.5
	11SC50	5	11H-11HS	8.625	⅞	5¼	1⅞	1⅞	12.7
	11SC70-14	7	14H	8.625	1⅞	6⅞	2⅞	1⅞	16.1
	11SC78-14	7½	14H	8.625	1⅞	6⅞	2⅞	1⅞	18.3
	11SC100-14	10	14H	8.625	2⅞	6⅞	4⅞	1⅞	24.5
12SC	12SC70	7	12H-12HS	10.000	⅞	5¼	2⅞	1⅞	23.2
	12SC70-14	7	14H	10.000	⅞	6⅞	2⅞	1⅞	21.2
	12SC78	7½	12H-12HS	10.000	1⅞	5¼	2⅞	1⅞	25.1
	12SC78-14	7½	14H	10.000	1⅞	6⅞	2⅞	1⅞	23.4
	12SC100-14	10	14H	10.000	2⅞	6⅞	3⅞	1⅞	29.5
13SC	13SC78	7½	13H-13HS	11.750	⅞	6⅞	3⅞	1⅞	38.4
14SC	14SC78	7½	14H	13.875	⅞	6⅞	2⅞	2¼	55.0

★ Flanges can be mixed to form different Between-Shaft Dimensions. See chart on page 23.
 • Approximate weight for each flange.

SC Spacer Hub Bores

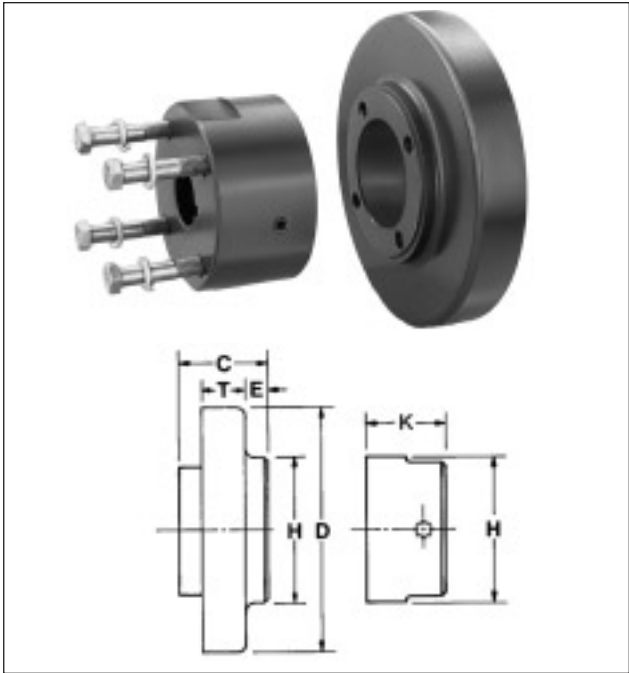
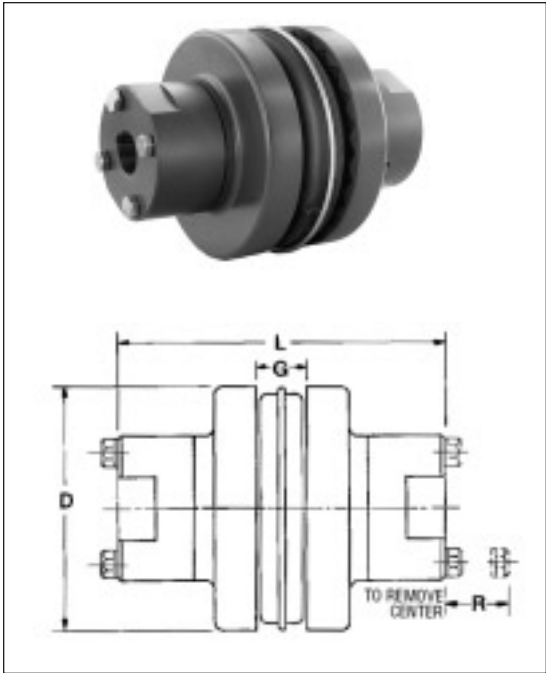

Coupling Size	Hub Number	Max. Bore	Stock Bores		Dimensions			Weight (Lbs.)•
			Plain Bore	Bore with Standard Keyway and Setscrew	K	H	Cap Screws Furnished	
4JSC	4H	1 1/8	1/2	5/8 - 7/8 - 1 - 1 1/8★	1 1/8	2	4 — 10x2	1.1
5SC	5H	1 1/8	1/2	5/8 - 3/4 - 1 - 1 1/8	1 3/32	2	4 — 10x1 1/2	.7
6SC	6H	1 1/8	5/8	3/4 - 7/8 - 1 - 1 1/8 - 1 1/4 - 1 1/2	1 1/32	2 1/2	4 — 1/2x1 1/4	1.3
7SC	7H	1 1/8	5/8	7/8 - 1 - 1 1/8 - 1 1/4 - 1 1/2 - 1 3/4	1 5/32	2 5/16	4 — 1/2x1 1/4	1.9
8SC	8H	1 1/8	3/4	7/8 - 1 - 1 1/8 - 1 1/4 - 1 1/2 - 1 3/4 - 1 1/2 - 1 3/4 - 1 1/2	1 7/32	3 1/4	4 — 7/8x2 1/4	3.2
9SC	9H	2 1/8	7/8	1 - 1 1/8 - 1 1/4 - 1 1/2 - 1 3/4 - 1 1/2 - 1 3/4 - 1 1/2 - 2 1/8	1 3/32	3 3/8	4 — 3/8x2 3/4	4.4
	9HS	1 1/2	1 1/8	1 7/32	3 3/8	4 — 3/8x2 1/4	3.7
10SC	10H	2 1/8	1 1/8	1 1/8 - 1 1/4 - 2 1/8 - 2 3/8	2 1/32	4 3/8	4 — 7/8x3	7.3
	10HS	1 1/8	1 1/8	1 7/32	4 3/8	4 — 7/8x2 1/2	5.5
11SC	11H	2 1/8	1 1/8	1 1/8 - 2 1/8 - 2 3/8 - 2 7/8	2 3/32	5 1/4	4 — 1/2x3 1/2	12.2
	11HS	1 1/8	1 1/8 - 1 1/8	1 7/32	5 1/4	4 — 1/2x2 3/4	9.3
12SC	12H	2 1/8	1 1/8	2 1/8 - 2 3/8 - 2 7/8	2 3/32	5 3/4	4 — 5/8x4	16.6
	12HS	2 1/2	2 3/8	2 17/32	5 3/4	4 — 5/8x3 1/2	14.1
13SC	13H	3 1/8	2 3/8 - 2 7/8 - 3 1/8	3 1/32	6 1/8	4 — 5/8x4 3/4	19.9
	13HS	2 1/2	2 1/2 - 2 3/8	2 9/32	6 1/8	4 — 5/8x3 1/2	16.0
14SC	14H	3 1/8	2 3/8 - 2 7/8 - 3 1/8 - 3 3/8	3 7/32	6 1/2	4 — 5/8x5	24.2

★ 4JSC x 1 1/8 has a shallow keyseat.
 • Approximate weight for each hub.



Between-Shaft Spacings

QUADRA-FLEX® Between-Shaft Spacings

Spacer couplings are available with the most popular between shaft dimensions. Spacings other than standard can be achieved by mixing flanges.

The “Standard” column provides spacings using identical

flanges; the “Combination” column provides spacings with mixed flanges; the column headed “Semi-Spacer” uses one flange that is not made for spacer coupling and therefore does not have a detachable hub.

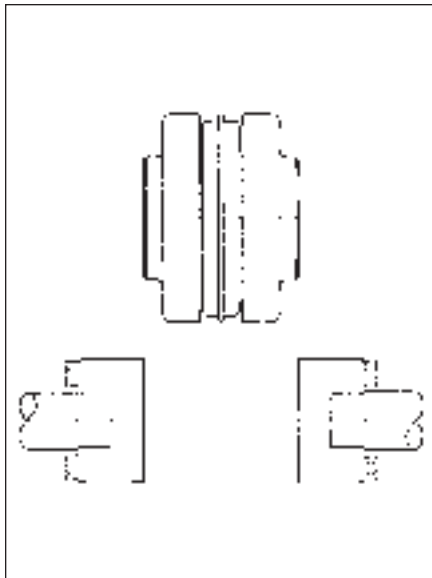

Standard

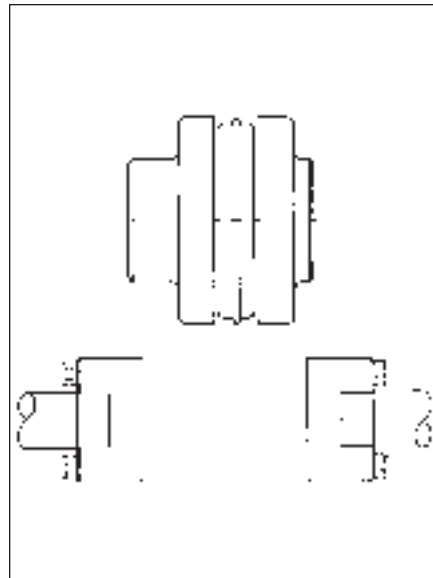

Combination

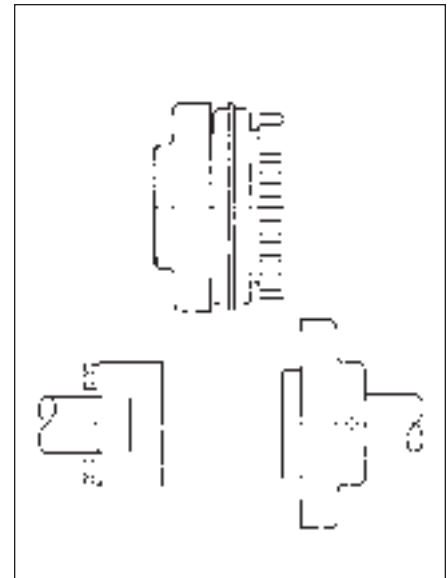

Semi-Spacer

Standard	
Spacing	Use Flanges★
3½	2 - () SC35
4½	2 - () SC44
5	2 - () SC50
7	2 - () SC70
7½	2 - () SC78
10	2 - () SC100

Combination	
Spacing	Use Flanges★
3⅝	SC35 & SC44
4½	SC35 & SC50
4⅞	SC44 & SC50
5¼	SC35 & SC70
5½	SC35 & SC78
5⅞	SC44 & SC70
6	SC50 & SC70
6⅛	SC44 & SC78
6½	SC50 & SC78
6¾	SC35 & SC100★★
7⅛	SC44 & SC100★★
7⅜	SC70 & SC78
7½	SC50 & SC100
8½	SC70 & SC100
8¾	SC78 & SC100

Semi-Spacer	
Spacing	Use Flanges★
1½	S & SC35
2⅝	S & SC44
2½	S & SC50
3½	S & SC70
4	S & SC78
5½	S & SC100

★ Check individual coupling size for flange availability.

★★ Non-Stock

NOTE: Other combinations available — consult factory.

Installation Instructions



Martin QUADRA-FLEX® flanges (hubs) and elastomeric elements (sleeves) come in a wide range of sizes and types. First, determine the size and type of coupling components required. Remove all components from their boxes and loosely assemble the coupling. **Do not install the wire ring on the two piece sleeves at this time.** Check maximum RPM values in table against operating speeds.

Martin EM sleeves are rated the same as other EPDM and Neoprene sleeves, and may be used interchangeably; however, Hytrel sleeves are rated at different values and may not be interchanged with Martin EM sleeves, or the EPDM and Neoprene sleeves. Check horsepower and torque ratings when selecting Hytrel sleeves.



Step 1. Make sure the motor driving the part or components is locked out electrically in such a manner that it cannot be started by anyone, however remote from the area. The same type of lockout procedure applies to any other driving device which may be used. Failure to follow these instructions may result in personal injury or property damage.

Step 2. Prepare shafts for coupling installation. Inspect all coupling components and remove any protective coating or lubricants from bores, mating surfaces, and fasteners.

Step 3. Slide one coupling flange onto each prepared shaft using key stock where required. With the QD Type B flange, it may be necessary to expand the QD bushing bore for ease of installation.

Step 4. Position the flange on the shafts to achieve the approximate "Y" dimension (distance between flanges) shown in table. It is best to have equal shaft length into each flange. Tighten one flange in position, and slide the other flange sufficient distance back to install sleeve. Do not install wire ring on two piece sleeve in its final position at this time, but allow it to hang loosely in groove next to teeth.

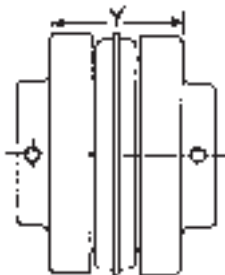

Step 5. Slide loose flange on the shaft until the sleeve has seated completely in teeth of both flanges. Refer to "Y" dimension although not a critical dimension. Secure the flange to shaft and torque set screws and cap screws to correct torque values.



Parallel



Angular

Step 6. Check parallel alignment by placing a straight edge across the two coupling flanges and measure the maximum offset at several points around the periphery of coupling. **Do not** rotate coupling when taking these measurements. Refer to table for maximum allowed offset of parallel alignment. Realign the coupling if necessary.

Step 7. Check angular alignment with a micrometer, vernier, or caliper. Take measurement from outside to outside of flanges at several points around the periphery of coupling. **Do not** rotate coupling when taking these measurements. Determine the difference between maximum and minimum dimensions and check to make sure they do not exceed the angular figure on the table. If a correction is necessary, recheck parallel alignment.

Maximum RPM and Allowable Misalignment (Dimensions in Inches)

Sleeve Size	Max. RPM	Types JEM, EM, E and N			★ Type H & HS		
		Parallel	Angular	Y	Parallel	Angular	Y
3	9200	.010	.035	1.188	—	—	—
4	7600	.010	.043	1.500	—	—	—
5	7600	.015	.056	1.938	—	—	—
6	6000	.015	.070	2.438†	.010	.016	2.500
7	5250	.020	.081	2.563	.012	.020	2.625
8	4500	.020	.094	2.938	.015	.025	3.000
9	3750	.025	.109	3.500	.017	.028	3.563
10	3600	.025	.128	4.053	.020	.032	4.125
11	3600	.032	.151	4.875	.022	.037	4.938
12	2800	.032	.175	5.688	.025	.042	5.750
13	2400	.040	.195	6.688	.030	.050	6.688
14	2200	.045	.242	7.750	.035	.060	7.813
16	1500	.062	.330	10.250	—	—	—

NOTE: Values shown above may apply if the actual torque transmitted is more than 1/2 the coupling rating. For lesser torque, reduce the above values by 1/2.

★ Type H & HS sleeves should not be used as direct replacements for JEM or EM sleeves.

† Value when using 6J flanges is 2.125.

Step 8. If the coupling employs the two-piece sleeve with wire ring, install ring in center groove of sleeve.

Note: Some force may be required to seat the ring in groove.

Step 9. Install protective guards and/or shields per OSHA and any other additional local or state safety codes as required. (See page 21.)

WARNING: Coupling sleeves may be forced from coupling when subjected to a severe shock load or abuse.

WARNING & SAFETY REMINDER

Safety must be considered a basic factor in machinery operation at all times. Most accidents are the result of carelessness or negligence. All rotating power transmission products are potentially dangerous and must be guarded by the contractor, installer, purchaser, owner, and user as required by applicable laws, regulations, standards, and good safety practice. Additional specific information must be obtained from other sources including the latest editions of American Society of Mechanical Engineers; Standard A.N.S.I. B15.1. A copy of this standard may be obtained from the American Society of Mechanical Engineers at 345 East 47th Street, New York, NY 10017 (212-705-7722).

It is the responsibility of the contractor, installer, purchaser, owner, and user to install, maintain, and operate the parts or components manufactured and supplied by  Sprocket & Gear, Inc., in such a manner as to comply with the Williams-Steiger Occupational Safety Act and with all state and local laws, ordinances, regulations, and the American National Standard Institute Safety Code.

CAUTION

Guards, access doors, and covers must be securely fastened before operating any equipment.

If parts are to be inspected, cleaned, observed, or general maintenance performed, **the motor driving the part or components is to be locked out electrically in such a manner that it cannot be started by anyone**, however remote from the area. Failure to follow these instructions may result in personal injury or property damage.

WARNING

NOTE: CATALOG DIMENSIONS

Every effort is made to keep all catalog dimensions and styles current in the catalog, however from time to time, it is necessary because of manufacturing changes to alter stock products dimensionally.

If any stock product dimension or style shown in this catalog is critical to your application please consult factory for certification.

Made-to-Order and Stock Products



Screw Conveyor Components and Accessories



ANGLE FLANGED "U" TROUGH
MILD STEEL AND GALVANIZED



FORM FLANGED "U" TROUGH
MILD STEEL AND GALVANIZED



SCREWS
HOT DIPPED GALVANIZED



SPECIALS



TUBULAR HOUSING
MILD STEEL AND GALVANIZED



TROUGH ENDS
DISCHARGE GATE
FLAT RACK AND PINION



WITH AND WITHOUT FEET
MILD STEEL AND GALVANIZED



SECTIONAL FLIGHTS
MILD STEEL



TAIL COUPLING
AND DRIVE SHAFTS



ELEVATOR BUCKETS



THRUST ASSEMBLY
TYPE E
WITH DRIVE SHAFT

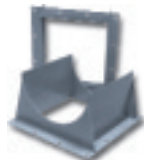

INLETS AND DISCHARGE SPOUTS
MILD STEEL AND GALVANIZED



SHAFT SEAL
SPLIT GLAND



HANGER STYLE 220
HANGER STYLE 226
MILD STEEL AND
GALVANIZED



HANGER
MILD STEEL AND
GALVANIZED



STYLE 216



SHAFT SEAL
COMPRESSION TYPE
PACKING GLAND



SHAFT SEAL
WASTE PACK



SHAFT SEAL
PLATE



SHAFT SEAL
FLANGED PRODUCT
DROP-OUT



HANGER
STYLE 70



HANGER
STYLE 19B



TROUGH END BEARINGS
BALL AND ROLLER

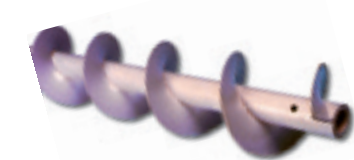

HELICOID SCREWS
RIGHT HAND AND LEFT HAND
MILD STEEL AND GALVANIZED



HELICOID FLIGHTING
RIGHT HAND AND LEFT HAND
MILD STEEL AND GALVANIZED.

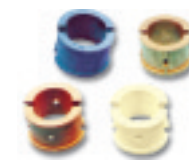

HANGER BEARINGS
STYLE 220/226
Martin HARD IRON
Martin BRONZE
NYLATRON
WOOD - GATKE



HANGER BEARINGS
HARD IRON
UHMW
WOOD
GATKE



SADDLES AND FEET

For more information about

Martin

and our other quality products,
join us at our web site

www.martinsprocket.com



SCREW CONVEYOR DRIVE
WITH ACCESSORIES



SPEED REDUCER
SHAFT MOUNTED
WITH ACCESSORIES.

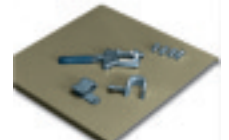

FLANGED COVER
WITH ACCESSORIES

All Steel Stock Sprockets

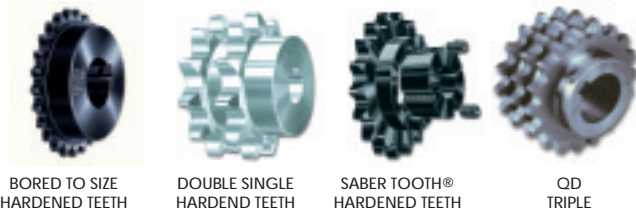

BORED TO SIZE
HARDENED TEETH

DOUBLE SINGLE
HARDENED TEETH

SABER TOOTH®
HARDENED TEETH

QD
TRIPLE

Stock Bushings/Hubs



BUSHINGS TYPE QD
STEEL WITH KEYSEAT
SIZE SF-N

TAPERED
BUSHING

QD IDLER
BUSHING

Stock Gears/Steel and Cast

Spur Gears - Stocked in both 14-1/2° & 20° Pressure Angles



SPUR TYPE B

SPUR 3 DP

GEAR RACK

BEVEL

MITER

WORM GEAR

WORM

Stock Timing Pulleys

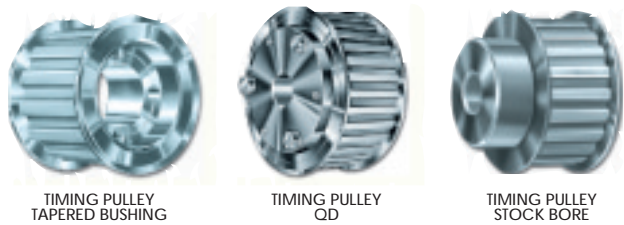

TIMING PULLEY
TAPERED BUSHING

TIMING PULLEY
QD

TIMING PULLEY
STOCK BORE

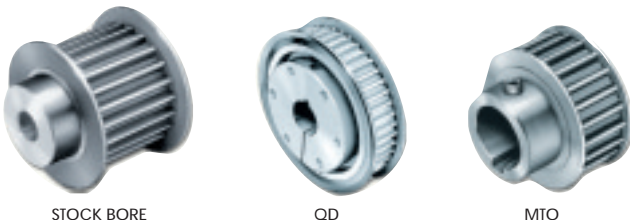

STOCK BORE

QD

MTO

Martin's NEW HTS (HIGH TORQUE SPROCKETS)

Stock QD V-Belt Sheaves

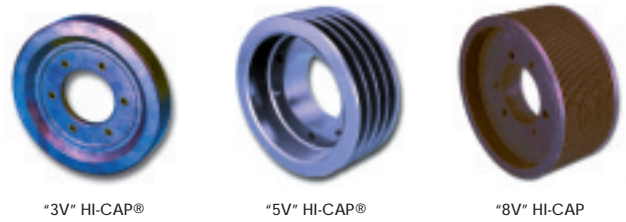

"3V" HI-CAP®

"5V" HI-CAP®

"8V" HI-CAP

Stock Tapered Bushed V-Belt Sheaves



CONVENTIONAL C SECTION
TAPER BUSHED

"3V" HI-CAP®
TAPER BUSHED

CONVENTIONAL B SECTION
TAPER BUSHED

Stock Couplings/Covers



RUBBER ELEMENT
Martin-FLEX®
STOCK BORE

ROLLER CHAIN
STOCK BORE

JAW

COUPLING
COVERS

FINISHED BORE

"QD"

SC SPACER

TPR ELEMENT

Martin's NEW QUADRA-FLEX® COUPLING

Stock Sintered Metal and Sintered Steel Products.



HANGER BEARINGS.



Extensive stockyards of screws are available for quick shipment.



A broad inventory of equipment ensures prompt worldwide delivery.



Quality material and an experienced staff means a rapid turnaround for you, our customer.

SERVICE CENTERS WORLDWIDE

USA

General Offices Sales and Manufacturing

Arlington, TX
3100 Sprocket Drive 76015-2898
P.O. Box 91588 • Arlington, Texas 76015-0088
817-258-3000 (FAX 817-258-3333)

Sales and Manufacturing

Danielsville, PA
3376 Delps Road 18038
P.O. Box 267 • Danielsville, PA 18038-0267
610-837-1841 (FAX 610-837-7337)

Ft. Worth, TX (Conveyor Division)

3600 McCart Street (76110-4692)
P.O. Box 1038 • Ft. Worth, TX 76101-1038
817-258-3000 (FAX 817-258-3173)

Mansfield, TX

811 4th Avenue 76063
P.O. Box 193 • Mansfield, TX 76063-0193
817-473-1520 (FAX 817-473-0465)

Montpelier, OH

350 Airport Road 43543
P.O. Box 29 • Montpelier, OH 43543-0029
419-485-5515 (FAX 419-485-3565)

Sacramento, CA

1199 Vine Street 95814-0426
P.O. Box 13856 • Sacramento, CA 95853-3856
916-441-7172 (FAX 916-441-4600)

Scottdale, GA

3303 Church Street 30079-1395
P.O. Box 886 • Scottdale, GA 30079-0886
404-292-8744 (FAX 404-292-7771)

Ft. Worth, TX (Tool & Forge Division)

3600 McCart Street 76110-4692
P.O. Box 1038 • Ft. Worth, TX 76101-1038
817-258-3000 (FAX 817-258-3173)

Mini Manufacturing Centers

Boston, MA
357 Fortune Boulevard
Milford, MA 01757
508-634-3990 (FAX 508-634-3998)

Charlotte, NC
3901 South I-85 Service Road 28208
Box 19447 • Charlotte, NC 28219-0447
704-394-9111 (FAX 704-394-9122)

Chicago, IL
1505 Birchwood Avenue 60018-3001
P.O. Box 1307 • Des Plaines, IL 60017-1307
847-298-8844 (FAX 847-298-2967)

Denver, CO
10800 East 54th Avenue 80239
P.O. Box 39208 • Denver CO 80239-0208
303-371-8466 (FAX 303-371-7116)

Houston, TX
9910 Bent Oak Drive 77040
P.O. Box 41209 • Houston, TX 77241-1209
713-849-4330 (FAX 713-849-4807)

Kansas City, MO
1520 N. Commerce Avenue 64120
P.O. Box 4961 • Kansas City, MO 64120-4961
816-231-5575 (FAX 816-231-1959)

Los Angeles, CA
5920 S. Triangle Dive
Commerce, CA 90040-3688
323-728-8117 (FAX 323-722-7526)

Minneapolis, MN
10601 Hampshire Avenue South
Bloomington, MN 55438-2395
952-829-0623 (FAX 952-944-9385)

Portland, OR
3030 N.W. Industrial
Portland, OR 97210-0046
503-223-7261 (FAX 503-221-0203)

Tampa, FL

3201 Queen Palm Drive Tampa FL 33619
813-623-1705 (FAX 813-626-8953)

Wayne, NJ

7 High Point Drive 07470-7432
P.O. Box 527 • Wayne, NJ 07474-0527
973-633-5700 (FAX 973-633-7196)

Manufacturing Only

Abilene, TX
Clarksville, TX
San Angelo, TX
Paragould, AR (Includes the Plastics Div.)

CANADA

Sales and Manufacturing

Martin Sprocket & Gear Canada Inc.
896 Meyerside Drive
Mississauga, Ontario, Canada L5T 1R9
905-670-1991 (FAX 905-670-2110)

Martin Sprocket & Gear Canada Inc. (Conveyor Division)
Box C3, RR #1
Ayr. Ontario, Canada NOB IEO
519-621-0546 (FAX 519-621-4413)

CHINA

Hong Kong
Shanghai
Fuzhou
Chengdo

MEXICO

Sales and Manufacturing

Martin Sprocket & Gear de Mexico, S.A. de C.V.
Km 52.8 Carretera, Naucalpan-Toluca
Parque Industrial, Toluca 2000
Calle 3, Manzana VII, Lote 11
Toluca Edo. de Mexico, C.P. 50200
011-52-72-790023 (FAX 011-52-72-790024)

Sold by the World's Greatest Sales People. Our Distributors.

Martin SPROCKET & GEAR, INC. 3100 SPROCKET DR. • ARLINGTON, TX 76015 • 817-258-3000

Martin Products are made in North America. For more information, contact your nearest **Martin** Distributor or Service Center.