



Hydraulic Wrench Sets Angle Openings

Convenient Angle Wrench Sets Keep Popular Sizes in Handy, Easy to Carry Roll Bags. 8 Sets Provide the Full Range of Openings in Chrome or Industrial Black Finish.

Chrome Sets

OB7K		OB11K		OB15K		OB18K	
OPENING	PART NO.	OPENING	PART NO.	OPENING	PART NO.	OPENING	PART NO.
$\frac{3}{8} \times \frac{3}{8}$	3710	$\frac{3}{8} \times \frac{3}{8}$	3710	$\frac{3}{8} \times \frac{3}{8}$	3710	$\frac{1}{2} \times \frac{1}{2}$	3710A
$\frac{7}{16} \times \frac{7}{16}$	3711	$\frac{7}{16} \times \frac{7}{16}$	3711	$\frac{7}{16} \times \frac{7}{16}$	3711	$\frac{3}{8} \times \frac{3}{8}$	3710
$\frac{1}{2} \times \frac{1}{2}$	3712	$\frac{1}{2} \times \frac{1}{2}$	3712	$\frac{1}{2} \times \frac{1}{2}$	3712	$\frac{7}{16} \times \frac{7}{16}$	3711
$\frac{9}{16} \times \frac{9}{16}$	3713	$\frac{9}{16} \times \frac{9}{16}$	3713	$\frac{9}{16} \times \frac{9}{16}$	3713	$\frac{1}{2} \times \frac{1}{2}$	3712
$\frac{5}{8} \times \frac{5}{8}$	3714	$\frac{5}{8} \times \frac{5}{8}$	3714	$\frac{5}{8} \times \frac{5}{8}$	3714	$\frac{9}{16} \times \frac{9}{16}$	3713
$\frac{11}{16} \times \frac{11}{16}$	3715	$\frac{11}{16} \times \frac{11}{16}$	3715	$\frac{11}{16} \times \frac{11}{16}$	3715	$\frac{5}{8} \times \frac{5}{8}$	3714
$\frac{3}{4} \times \frac{3}{4}$	3716	$\frac{3}{4} \times \frac{3}{4}$	3716	$\frac{3}{4} \times \frac{3}{4}$	3716	$\frac{11}{16} \times \frac{11}{16}$	3715
Roll Bag	C70	$\frac{13}{16} \times \frac{13}{16}$	3717	$\frac{13}{16} \times \frac{13}{16}$	3717	$\frac{3}{4} \times \frac{3}{4}$	3716
		$\frac{7}{8} \times \frac{7}{8}$	3718	$\frac{7}{8} \times \frac{7}{8}$	3718	$\frac{13}{16} \times \frac{13}{16}$	3717
		$\frac{15}{16} \times \frac{15}{16}$	3719	$\frac{15}{16} \times \frac{15}{16}$	3719	$\frac{7}{8} \times \frac{7}{8}$	3718
		1 x 1	3720	1 x 1	3720	$\frac{15}{16} \times \frac{15}{16}$	3719
		Roll Bag	C111	$\frac{1}{8} \times \frac{1}{8}$	3721	1 x 1	3720
				$\frac{1}{4} \times \frac{1}{4}$	3722	$\frac{1}{8} \times \frac{1}{8}$	3721
				$\frac{3}{8} \times \frac{3}{8}$	3723	$\frac{1}{4} \times \frac{1}{4}$	3722
				Roll Bag	C180	$\frac{1}{2} \times \frac{1}{2}$	3723
						$\frac{3}{8} \times \frac{3}{8}$	3724
						$\frac{1}{2} \times \frac{1}{2}$	3725
						Roll Bag	3726
							C180

Industrial Black Sets

BOB7K		BOB11K		BOB15K		BOB18K	
OPENING	PART NO.	OPENING	PART NO.	OPENING	PART NO.	OPENING	PART NO.
$\frac{3}{8} \times \frac{3}{8}$	BLK3710	$\frac{3}{8} \times \frac{3}{8}$	BLK3710	$\frac{3}{8} \times \frac{3}{8}$	BLK3710	$\frac{1}{2} \times \frac{1}{2}$	BLK3710A
$\frac{7}{16} \times \frac{7}{16}$	BLK3711	$\frac{7}{16} \times \frac{7}{16}$	BLK3711	$\frac{7}{16} \times \frac{7}{16}$	BLK3711	$\frac{3}{8} \times \frac{3}{8}$	BLK3710
$\frac{1}{2} \times \frac{1}{2}$	BLK3712	$\frac{1}{2} \times \frac{1}{2}$	BLK3712	$\frac{1}{2} \times \frac{1}{2}$	BLK3712	$\frac{7}{16} \times \frac{7}{16}$	BLK3711
$\frac{9}{16} \times \frac{9}{16}$	BLK3713	$\frac{9}{16} \times \frac{9}{16}$	BLK3713	$\frac{9}{16} \times \frac{9}{16}$	BLK3713	$\frac{1}{2} \times \frac{1}{2}$	BLK3712
$\frac{5}{8} \times \frac{5}{8}$	BLK3714	$\frac{5}{8} \times \frac{5}{8}$	BLK3714	$\frac{5}{8} \times \frac{5}{8}$	BLK3714	$\frac{9}{16} \times \frac{9}{16}$	BLK3713
$\frac{11}{16} \times \frac{11}{16}$	BLK3715	$\frac{11}{16} \times \frac{11}{16}$	BLK3715	$\frac{11}{16} \times \frac{11}{16}$	BLK3715	$\frac{5}{8} \times \frac{5}{8}$	BLK3714
$\frac{3}{4} \times \frac{3}{4}$	BLK3716	$\frac{3}{4} \times \frac{3}{4}$	BLK3716	$\frac{3}{4} \times \frac{3}{4}$	BLK3716	$\frac{11}{16} \times \frac{11}{16}$	BLK3715
Roll Bag	C70	$\frac{13}{16} \times \frac{13}{16}$	BLK3717	$\frac{13}{16} \times \frac{13}{16}$	BLK3717	$\frac{3}{4} \times \frac{3}{4}$	BLK3716
		$\frac{7}{8} \times \frac{7}{8}$	BLK3718	$\frac{7}{8} \times \frac{7}{8}$	BLK3718	$\frac{13}{16} \times \frac{13}{16}$	BLK3717
		$\frac{15}{16} \times \frac{15}{16}$	BLK3719	$\frac{15}{16} \times \frac{15}{16}$	BLK3719	$\frac{7}{8} \times \frac{7}{8}$	BLK3718
		1 x 1	BLK3720	1 x 1	BLK3720	$\frac{15}{16} \times \frac{15}{16}$	BLK3719
		Roll Bag	C111	$\frac{1}{8} \times \frac{1}{8}$	BLK3721	1 x 1	BLK3720
				$\frac{1}{4} \times \frac{1}{4}$	BLK3722	$\frac{1}{8} \times \frac{1}{8}$	BLK3721
				$\frac{3}{8} \times \frac{3}{8}$	BLK3723	$\frac{1}{4} \times \frac{1}{4}$	BLK3722
				Roll Bag	C180	$\frac{1}{2} \times \frac{1}{2}$	BLK3723
						$\frac{3}{8} \times \frac{3}{8}$	BLK3724
						$\frac{1}{2} \times \frac{1}{2}$	BLK3725
						Roll Bag	BLK3726
							C180

Service Wrenches

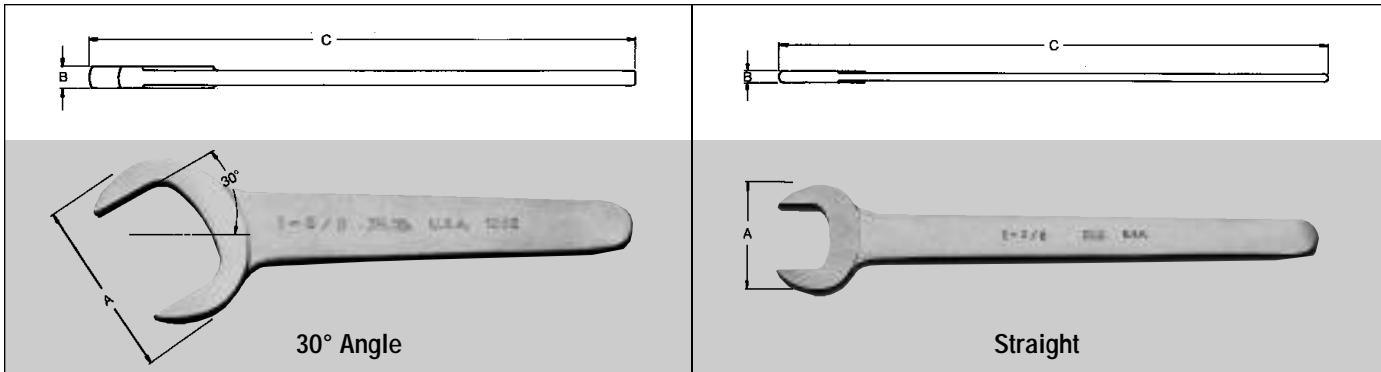

30° Angle Service Wrenches

Wrench Opening	Diameter of Head	Thickness of Head	Length	Wt. Ea. Lbs.	Chrome	Industrial Black	Std. Pkg. Qty.	Wrench Opening	CHROME SET 30°																																																	
	A	B			Part No.	Part No.			SW11K																																																	
3/8	1 1/16	1/4	6 1/4	.22	1224	BLK-1224	6	3/8	INDUSTRIAL BLACK SET 30°																																																	
13/16	1 1/16	1/4	6 1/4	.22	1226	BLK1226	6	13/16	BSW11K																																																	
7/8	1 1/4	1/4	6 1/4	.22	1228	BLK1228	6	7/8	<table border="1"> <thead> <tr> <th>OPENING</th> <th>CHROME PART NO.</th> <th>BLACK PART NO.</th> </tr> </thead> <tbody> <tr><td>3/8</td><td>1224</td><td>BLK-1224</td></tr> <tr><td>13/16</td><td>1226</td><td>BLK1226</td></tr> <tr><td>7/8</td><td>1228</td><td>BLK1228</td></tr> <tr><td>15/16</td><td>1230</td><td>BLK-1230</td></tr> <tr><td>1</td><td>1232</td><td>BLK1232</td></tr> <tr><td>1 1/16</td><td>1234</td><td>BLK1234</td></tr> <tr><td>1 1/8</td><td>1236</td><td>BLK1236</td></tr> <tr><td>1 1/4</td><td>1238</td><td>BLK1238</td></tr> <tr><td>1 1/2</td><td>1240</td><td>BLK1240</td></tr> <tr><td>1 5/8</td><td>1242</td><td>BLK1242</td></tr> <tr><td>1 3/4</td><td>1244</td><td>BLK1244</td></tr> <tr><td>1 7/8</td><td>1246</td><td>BLK1246</td></tr> <tr><td>1 1/2</td><td>1248</td><td>BLK1248</td></tr> <tr><td>1 9/16</td><td>1250</td><td>BLK1250</td></tr> <tr><td>1 5/8</td><td>1252</td><td>BLK1252</td></tr> </tbody> </table>		OPENING	CHROME PART NO.	BLACK PART NO.	3/8	1224	BLK-1224	13/16	1226	BLK1226	7/8	1228	BLK1228	15/16	1230	BLK-1230	1	1232	BLK1232	1 1/16	1234	BLK1234	1 1/8	1236	BLK1236	1 1/4	1238	BLK1238	1 1/2	1240	BLK1240	1 5/8	1242	BLK1242	1 3/4	1244	BLK1244	1 7/8	1246	BLK1246	1 1/2	1248	BLK1248	1 9/16	1250	BLK1250	1 5/8	1252	BLK1252
OPENING	CHROME PART NO.	BLACK PART NO.																																																								
3/8	1224	BLK-1224																																																								
13/16	1226	BLK1226																																																								
7/8	1228	BLK1228																																																								
15/16	1230	BLK-1230																																																								
1	1232	BLK1232																																																								
1 1/16	1234	BLK1234																																																								
1 1/8	1236	BLK1236																																																								
1 1/4	1238	BLK1238																																																								
1 1/2	1240	BLK1240																																																								
1 5/8	1242	BLK1242																																																								
1 3/4	1244	BLK1244																																																								
1 7/8	1246	BLK1246																																																								
1 1/2	1248	BLK1248																																																								
1 9/16	1250	BLK1250																																																								
1 5/8	1252	BLK1252																																																								
15/16	1 1/2	1/4	6 1/4	.25	1230	BLK-1230	6	15/16																																																		
1	1 1/2	1/4	6 1/4	.25	1232	BLK1232	6	1																																																		
1 1/16	1 1/8	1/4	6 1/4	.25	1234	BLK1234	6	1 1/16																																																		
1 1/8	2 1/16	1/4	7	.31	1236	BLK1236	6	1 1/8																																																		
1 1/4	2 1/16	1/4	7	.31	1238	BLK1238	6	1 1/4																																																		
1 1/2	2 1/8	1/4	7	.30	1240	BLK1240	6	1 1/2																																																		
1 5/8	2 1/8	1/4	7	.30	1236S	BLK1236S	6	1 5/8																																																		
1 3/4	2 1/2	5/16	7 1/8	.45	1242	BLK1242	6	1 3/4																																																		
1 7/8	2 1/2	5/16	7 1/8	.44	1244	BLK1244	6	1 7/8																																																		
1 1/2	2 1/2	5/16	7 1/8	.43	1246	BLK1246	6	1 1/2																																																		
1 1/4	2 1/2	5/16	7 1/8	.42	1248	BLK1248	6	1 1/4																																																		
1 1/8	2 1/2	5/16	7 1/8	.43	1250	BLK1250	6	1 1/8																																																		
1 1/16	2 1/2	5/16	7 1/8	.43	1252	BLK1252	6	1 1/16																																																		
1 1/8	2 3/8	5/16	8 1/2	.70	1256	BLK1256	6	1 1/8																																																		
1 1/4	3 1/8	5/16	8 1/2	.69	1258	BLK1258	6	1 1/4																																																		
1 1/2	3 1/8	5/16	8 1/2	.69	1260	BLK1260	6	1 1/2																																																		
1 3/4	3 1/8	5/16	8 1/2	.68	1262	BLK1262	6	1 3/4																																																		
1 5/8	3 1/2	5/16	8 1/2	.66	1264	BLK1264	6	1 5/8																																																		
1 7/8	3 1/2	5/16	8 1/2	.65	1268	BLK1268	6	1 7/8																																																		
2	3 1/2	5/16	8 1/2	.61	1272	BLK1272	6	2																																																		
2 1/8	3 1/2	5/16	9 1/2	.61	1276	BLK1276	6	2 1/8																																																		
2 1/4	3 1/2	5/16	9 1/2	.59	1272S	BLK1272S	6	2 1/4																																																		
2 1/2	3 1/2	5/16	9 1/2	.57	1264S	BLK1264S	6	2 1/2																																																		
2 3/8	3 1/2	5/16	9 1/2	.57	1264S	BLK1264S	6	2 3/8																																																		

Straight Service Wrenches

Wrench Opening	Diameter of Head	Thickness of Head	Length	Wt. Ea. Lbs.	Chrome	Std. Pkg. Qty.	Wrench Opening
	A	B			Part No.		
1	2 1/2	1/4	12 1/4	.77	1932	6	1
1 1/8	2 1/2	1/4	12 1/4	.73	1936	6	1 1/8
1 1/2	2 1/2	5/16	12 1/4	.93	1948	6	1 1/2
1 3/4	2 1/2	5/16	12 1/4	.92	1952	6	1 3/4
1 1/4	3 1/16	5/16	12 1/4	1.3	1956	6	1 1/4
2	3 1/16	5/16	12 1/4	1.3	1964	6	2
2 1/4	3 1/16	5/16	12 1/4	1.3	1972	6	2 1/4