

Tee-Handle Socket Wrenches



Upset Forged from Carbon Steel

Special Lengths Can Be Ordered in Quantities.

Can Be Used as Tee-Handle or Pin Handle. Can Be Removed, Enabling Use of a Wrench on Hexagon End of Shank.

Square Opening 4-Point								
Wrench Opening	Diameter of Head	Size Hex on Handle End	Length of Pin Handle	Overall Length	Wt. Ea. Lbs.	Industrial Black	Std. Pkg. Qty.	Wrench Opening
	A	B	C	D		Part No.		
3/16	1/2	13/32	4 1/2	4 1/4	.12	961H	6	3/16
1/4	1/2	13/32	4 1/2	4 1/4	.12	961J	6	1/4
5/16	3/8	17/32	4 1/2	4 1/2	.17	962H	6	5/16
3/8	11/16	5/8	4 1/2	4 1/2	.29	963H	6	3/8
7/16	7/8	3/4	5 1/2	5 1/4	.57	965H	12	7/16
1/2	1	3/4	6 1/8	6 1/8	.68	966H	12	1/2
5/8	1 1/8	7/8	6 1/8	6 1/2	.94	967H	6	5/8
3/4	1 1/4	7/8	7	7	1.18	968H	6	3/4
7/8	1 1/2	7/8	7	7 3/8	1.20	969H	1	7/8
1	1 3/4	1 1/4	8 1/4	8 1/4	2.2	971H	1	1

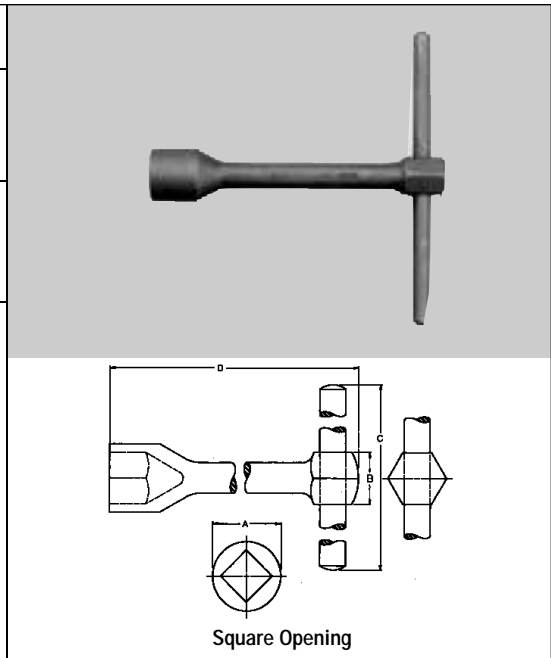

Hexagon Opening 6-Point								
Wrench Opening	Diameter of Head	Size Hex on Handle End	Length of Pin Handle	Overall Length	Wt. Ea. Lbs.	Industrial Black	Std. Pkg. Qty.	Wrench Opening
	A	B	C	D		Part No.		
5/16	1/2	13/32	4 1/2	4 1/4	.12	961A	6	5/16
3/8	3/8	17/32	4 1/2	4 1/2	.17	962D	6	3/8
7/16	11/16	5/8	4 1/2	4 1/2	.28	963D	6	7/16
1/2	3/4	11/16	5 1/2	5 1/4	.40	964A	12	1/2
5/8	7/8	3/4	5 1/2	5 3/4	.56	965D	12	5/8
3/4	1	3/4	6 1/8	6 1/8	.68	966D	12	3/4
7/8	1 1/8	7/8	6 1/8	6 1/2	.94	967A	6	7/8
1	1 1/4	7/8	6 1/8	6 1/2	.91	967D	6	1
1 1/16	1 1/2	1 1/16	7	7 3/8	1.24	969A	1	1 1/16
1 1/8	1 1/2	1 1/16	7 1/8	7 1/8	1.8	970S	1	1 1/8
1 1/4	1 1/2	1 1/16	7 1/8	7 1/8	1.9	970D	1	1 1/4
1 1/2	1 3/4	1 1/4	8 1/4	8 1/4	2.3	971A	1	1 1/2
1 3/4	1 3/4	1 1/4	8 1/4	8 1/4	2.2	971D	1	1 3/4
1 7/8	1 3/4	1 1/4	8 1/4	9 1/8	3.0	973A	1	1 7/8
1 15/16	1 3/4	1 1/4	8 1/4	9 1/8	2.9	973B	1	1 15/16
1 1/2	2 1/8	1 7/16	8 1/4	10	3.8	975D	1	1 1/2
1 5/8	2 1/4	1 7/8	10 3/8	10 3/8	5.5	976A	1	1 5/8

