

Martin

HEAVY-DUTY CONVEYOR PULLEYS AND IDLERS

PROFILED END DISC PULLEYS
CLEAN FLIGHT® WING PULLEYS
ENGINEERED CLASS PULLEYS
CEMA C, D, E IDLERS
COMPLETE BELT CONVEYORS

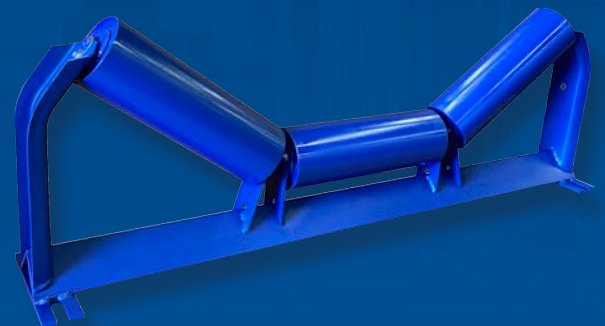
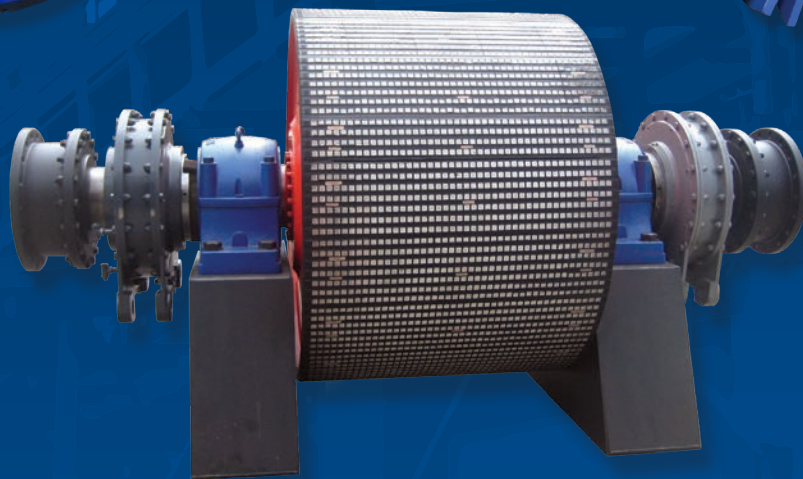

Whether you're moving light or extreme bulk materials, Martin has a vast inventory of reliable conveyor pulleys to fit your application needs.

Martin heavy-duty conveyor pulleys are manufactured to deliver optimum performance and longevity in the harshest of environments.

- Extensive inventories stocked nationwide
- Made-to-order pulleys
Drum pulleys, wing pulleys, Clean Flight® wing pulleys and engineered class pulleys
- Shafting, take-up frames, bushings, lagging and complete assemblies available
- Exceptional delivery times to maximize your uptime
- All stock conveyor pulleys are crown face and flat face is available upon request



Martin profiled end disc pulleys are engineered to offer an efficient and improved alternative to standard stock drum pulleys. Martin profiled end disc pulleys simplify the selection as they can be used in a wide range of applications from standard, mine, and quarry duty, thus reducing your replacement inventory. Instead of deciding what might be the best pulley for your application, now you have one choice that conveys them all.



Martin profiled end disc pulleys are designed to meet today's demanding applications by offering the following standard benefits:

Profiled Integral End Disc

- True-turbine profile end discs that distribute stress more evenly.
- Moves stress away from the hub and reduce the risk of failure.

Weldment

- Submerged arc welding with machined-in weld preparation provides maximum weld penetration.

Optimization

- Stocked with MXT® bushings but available for keyless locking devices.

Optimized end disc profile

Profiled end disc pulleys are designed to meet today's demanding applications by utilizing a profiled integral end disc. The true-turbine profiled end disc distributes stress more evenly than a welded hub design, moving stress away from the hub and reducing the risk of pulley failure.

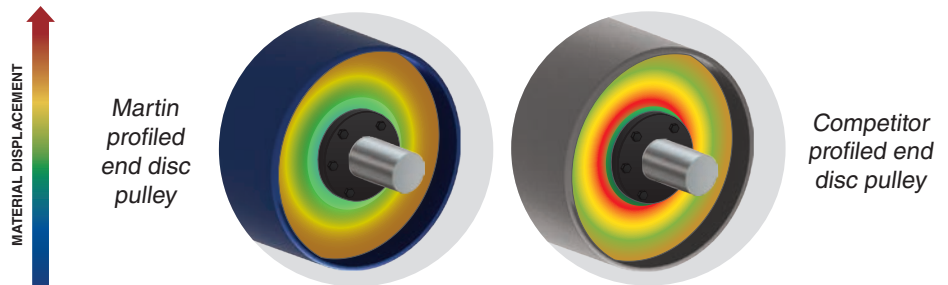

Eliminating hub to end disc weld

Hub to end disc weld failure on a pulley with a welded hub is a common failure mode due to shaft deflection or cycle fatigue. The profiled end disc pulley utilizes an integral hub design with a flexible end disc and by removing the end disc to hub weld greatly reduces the chance of end disc failure.

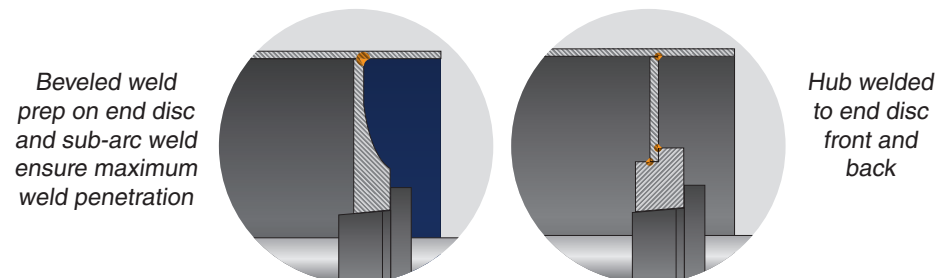



Mine Duty Drum Pulley

- 10" To 60" diameter
- .375" Minimum rim thickness
- 1", 1.25", And heavier end discs
- .375" Center plates
- Rolled rim, trimmed and hydraulically seated around end discs
- Several hub/bushing system options
- Double sub-arc weldment
- Crowned face, flat face available upon request



Quarry Duty Drum Pulley

- 12" To 60" diameter
- .5" Minimum rim thickness
- 1.25" And heavier end discs
- .5" Center plates
- Full depth key bushings
- Rolled rim, trimmed and hydraulically seated around end discs
- Several hub/bushing system options
- Double sub-arc weldment
- Crowned face, flat face available upon request

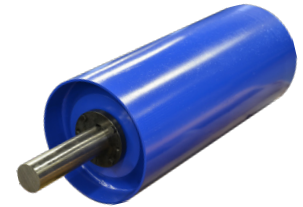

Profiled End Disc Drum Pulley

- 12" to 36" diameter
- .25" To .375" Minimum rim thickness
- 1" And heavier end discs
- .5" Center plates
- Full depth key bushings
- Rolled rim, trimmed and hydraulically seated around end discs
- Several hub/bushing system options
- Double sub-arc weldment
- Crowned face, flat face available upon request

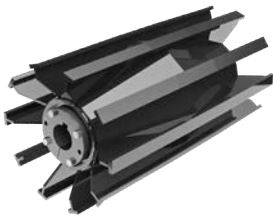

Standard Duty Wing Pulley

- Available in 6" thru 60" diameter
- Minimum .375" x 1.25" contact bars
- Minimum .25" thick wings
- Minimum 10 GA gussets
- Unique pipe end design, better protection against wing folding and hub-weld fatigue
- Several hub/bushing system options
- Crowned face, flat face available upon request



Mine Duty Wing Pulley

- Available in 8" thru 60" diameter
- Minimum .625" x 1.5" contact bars
- Minimum .375" thick wings
- Minimum .25" gussets
- Unique pipe end design, better protection against wing folding and hub-weld fatigue
- Several hub/bushing system options
- Crowned face, flat face available upon request

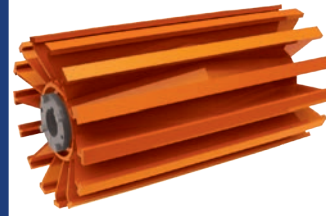

Quarry Duty Wing Pulley

- Available in 10" thru 60" diameter
- Minimum .75" x 2" contact bars
- Minimum .375" thick wings
- Minimum .25" gussets
- Full depth keyed bushings for higher clamping to shaft
- Unique pipe end design, better protection against wing folding and hub-weld fatigue
- Several hub/bushing system options
- Crowned face, flat face available upon request

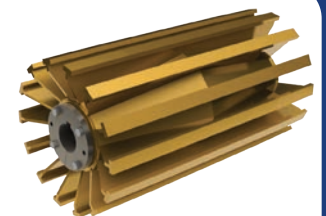

Quarry Duty AR Wing Pulley

- Available in 10" thru 60" diameter
- Minimum .75" x 2" contact bars of "AR400" abrasive resistant steel
- Minimum .5" thick wings
- Minimum .25" gussets
- Full depth keyed bushings for higher clamping to shaft
- Unique pipe end design, better protection against wing folding and hub-weld fatigue
- Several hub/bushing system options
- Crowned face, flat face available upon request

Martin provides pulleys for a wide variety of applications. Some special pulleys include dead shaft pulleys, elevator pulleys, and stainless steel pulleys.

Types:

- CFW - Clean Flight® wing pulleys
- Spiral pulleys
- Dead shaft pulleys (DSP)
- Gudgeon rollers
- Cage rollers
- V-guide drums
- Wide drag and drum sprockets

Clean Flight® Wing Pulleys



- **Innovative patented construction incorporates the material rejection technology of a screw conveyor.**
- **Aggressive construction.**
- Offered in:
 - Standard duty
 - Mine duty
 - Quarry duty
- Also available:
 - Assembled unit with shaft and bearings
 - Dead shaft design

Spiral Drum and Wing Pulleys



- **Reverse helices** wrapped around outer diameter.
- **Pulley flat bar is under the spiral wrap** for added protection on Wing Pulley.
- **Larger welds** provide a better bond between the wrap and pulley.
- **Designed to remove material from belt.**
- Available in wing or drum style:
 - Standard duty
 - Mine duty
 - Quarry duty

DSP Dead Shaft Pulleys



- **Aggressive construction.**
- **Piloted flange cartridge** - easily interchangeable with other brands.
- **Standard off the shelf integral bearing.**
- **3/4" thick fabricated steel mounting pedestals.**
- **Increased diameter shafting behind bearings** to reduce deflection.
- **Available in standard duty, mine duty, quarry duty and quarry duty AR.**
- **Wing, drum style or clean flight® wing.**

Cage Rollers

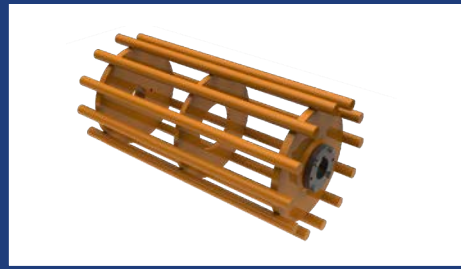

- **Cage rollers are effective in allowing material to fall through the pulley.**
- **Cage rollers for belt conveyors are available in almost any custom size.**

Gudgeon Rollers



- **Thick wall pipe or tube fabrication.**
- **Special design and assembly** eliminates shaft and end disc weld fatigue.
- **Designed to convey bulk product without a conveyor belt.**
- **Perfect for logging, lumber mills, steel mills and palletized product applications.**

The martin engineered class pulley (ECP) line can be used effectively in every industry to ensure optimum performance and pulley longevity.

Available as:

- EMD - Engineered Mine Duty
- TD - Turbo Disc Pulley
- TB - T-Bottom Pulley
- DSP - Dead Shaft Engineered Class Pulley

All ECP are:

- Statically balanced
- Machined face is available
- Two year warranty

EMD Engineered Mine Duty

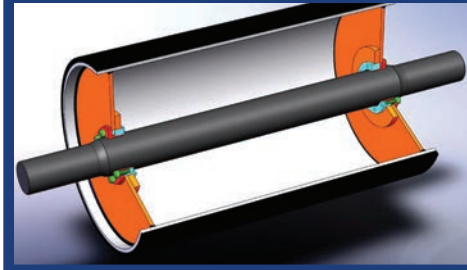

- **Solid plate end discs** with backing rings to support reaction forces of keyless locking elements.
- **Full penetration weld between end disc and rim.**
- **Full penetration longitudinal weld in rim.**
- **End discs are welded internally and externally to the rim.**
- **Single engagement keyless locking device.**

TD Turbo Disc Pulleys

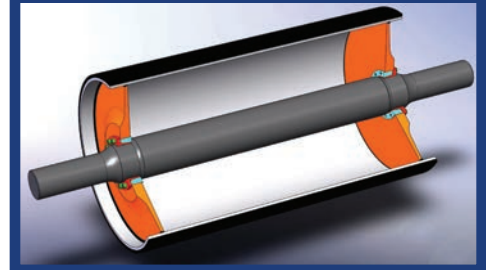

- **One piece machined and profiled end disc** with a custom engineered radius at the transition between the locking element and the rim.
- **Full penetration weld between end disc and rim.**
- **Full penetration longitudinal weld in rim.**
- **End discs are welded internally and externally to the rim.**
- **Single or double engagement keyless locking device.**

TB T-Bottom Pulleys

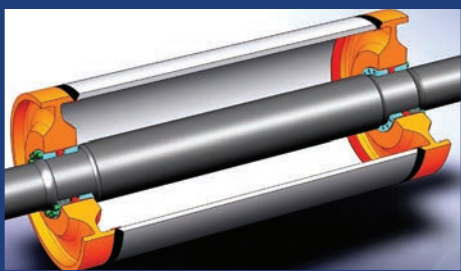

- **Integral rim and double profiled end disc** with submerged arc weldment fusing T-bottom end discs with rim.
- **Full penetration weld between end disc and rim.**
- **Full penetration longitudinal weld in rim.**
- **Double engagement keyless locking device.**

DSP Dead Shaft Pulleys

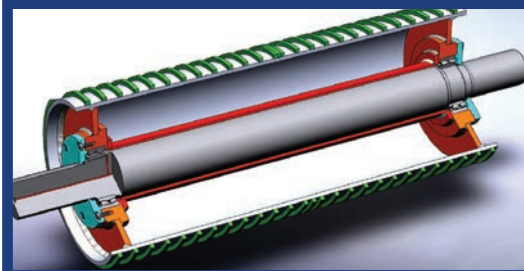

- **Problem solving design** for heavy contamination, space restrictions, reduced moment arm.
- **Double lip seal spherical roller bearings.**
- **Lubrication through shaft.**
- **Inner grease tube** in place of backside bearing seals.
- **Support pedestals** are sized to replace standard or existing pillow blocks with the same bolt pattern and shaft height. The shaft is held in pedestals with a keyless locking device.

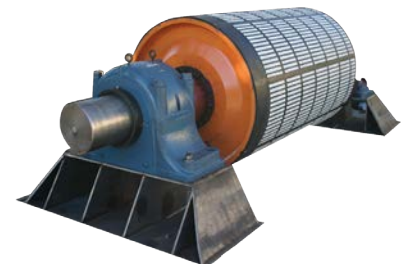
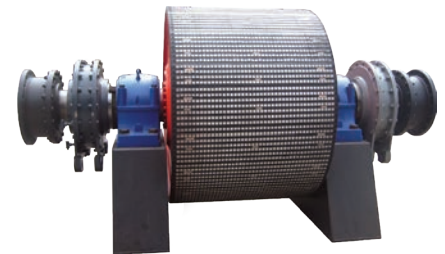

Martin's lagging is designed to meet the demands of your application. We offer various types, custom-fit to your application: Vulcanized Rubber, Ceramic, Cold Bond, and Slide Lagging.

Available Lagging Options:

- AR
- SOF
- Ceramic (Hot Vulcanized)
- MSHA
- Molded Urethane
- Cold Bond
- Weld-On Strip

Cost Saving Tips



Save up to 50 - 60% on Pulley replacement costs for Conveyor Pulleys with lagging.

Scan for more information



SOF Static Conductive / Oil Resistant / Flame Resistant

- SOF lagging reduces the risk of explosion, and fire or oil related lagging failures.
- The self-extinguishing characteristics of SOF make it ideal for use in grain and fertilizer applications.



AR Abrasive Resistant Lagging

- Popular for rugged applications or conveying abrasive materials.
- This lagging mimics the tires of giant "quarry loaders" that withstand the harshest environments.



MSHA Mine and Safety Hazard Approved Lagging

- Should be used in all underground coal mining applications and any application where fire safety is imperative.
- Can be shipped as plain, herringbone or diamond groove patterns.



Weld-On Strip

- Weld-On Strip Lagging is available from stock and is easily installed on Drum Pulleys either in our facilities or in the field.
- Stocked in 72" strips with retainers in diameters from 10" to 48".
- Available in 60 durometer SBR, 40 durometer rubber, EPDM and SOF.

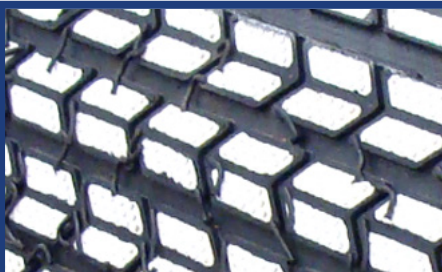

Ceramic Hot Vulcanized

- Vulcanized Ceramic Lagging by Martin has proven to be the best in the industry.
- Martin has worked closely with independent testing labs to study adhesion strengths of several bonding methods. Our studies found that the Martin yield an 83% higher bonding strength than conventional cold bonding methods for ceramic lagging.



Urethane

- Urethane lagging is more apt to shed sticky materials and is also more abrasive resistant than regular SBR.
- Urethane lagging can be altered to a herringbone or diamond groove pattern.

Martin manufactures heavy-duty Idlers and components that exceed CEMA standards. Martin uses sealed-for-life ball bearings that allows for trouble-free life even in the harshest applications. With Idlers available when and where you need them, Martin can provide the complete solution for your belt conveyor needs.

Belt conveyors are a proven way to move bulk materials in practically every industry. Belt conveyors routinely operate at 90% capacity and can be operated 24/7, 365 days per year. Belt conveyors have a lower operating cost and can provide a higher return on investment than competitive methods. Maintenance is minimized and less labor is required. Materials conveyed can range from very fine powder such as gypsum to large lump size material such as limestone from a quarry. The size of material conveyed is limited by the belt width used.

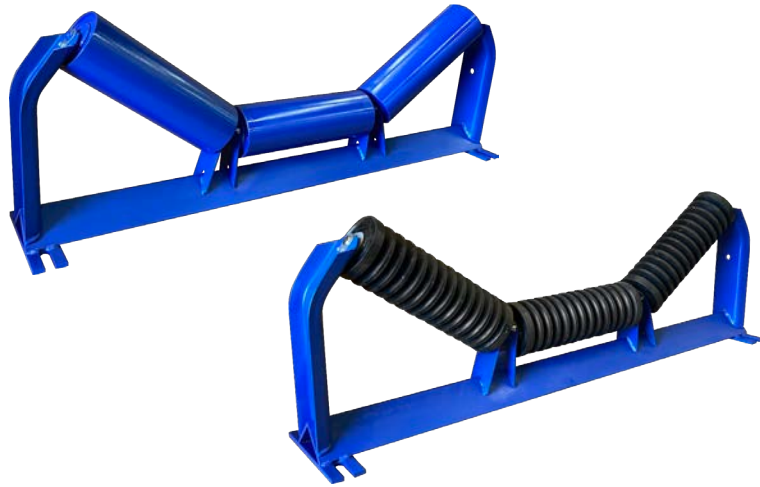

Martin Idlers are stocked in a wide range of belt widths to meet customers' needs.

Martin offers **Drop-in Idlers**, with slotted ends or hex nuts. **Request a Quote Online**

Scan for more information



The triple labyrinth seal system offers the following bearing protection:

- 1 Large External shield**
Shields the labyrinth & bearing from outside contaminants
- 2 Contact lip seal**
Adds a level of protection against moisture & fine contaminants
- 3 Flinger design**
Removes contaminates away from the bearing housing by centrifugal force
- 4 Grease filled triple labyrinth**
Catch contaminants attempting to pass through the labyrinth
- 5 Protected weld**
Welded inside the tubing instead of an exposed corner weld

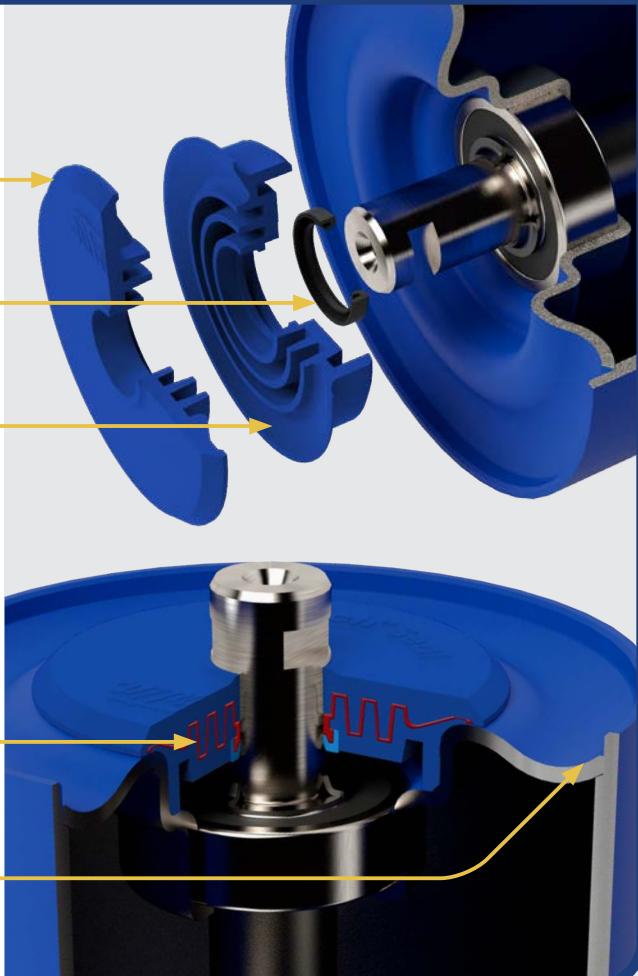

Specifications and Features

Idlers are maintenance-free. Martin idlers use sealed-for-life ball bearings that allows for trouble-free life in the harshest applications

- Low rolling resistance that allows for the lowest total operating cost
- Engineered for low roller runout (TIR)
- Offered in a wide range of belt widths from 18" to 96"
- Wide range of belt size available product:
 - » CEMA C: 18" to 60"
 - » CEMA D: 24" to 72"
 - » CEMA E: 36" to 94"

Martin idlers are stocked in a wide range of belt widths to meet customers' needs.

Request a Quote Online



Scan for more information



Impact Idlers



- **Rubber disc absorb impact** to dissipate shock loads to bearings, idler frame, and conveyor structure.
- **60 durometer rubbers discs** are pressed onto a steel tube.
- **Each roll is designed to absorb the impact and protect the belt** from sharp edged material.
- **Impact idler frames are reinforced** to increase strength.
- **Idler assemblies are typically spaced as close together as possible** to enable the load to be absorbed by a greater number of idler rolls.
- **Impact rollers are locked in tightly** to avoid roller shafts bouncing and wearing of the middle bracket.
- **Made-to-order removable end-plates** are offered for easy roller change.

Other Idlers Products:

- Galvanized frames
- Garland/catenary
- Belt saver brackets
- Scale quality rolls
- Urethane covered rolls
- Live shaft rolls
- Impact beds
- Channel inset idlers
- And more



Unequal Idlers



Unequal idlers (picking) are used due to their lower profile design. Typically consist of one long roll in the center and two short inclined wing rollers. This design lays out the material and allows for easy sorting and separation. Unequal idlers (picking) are available with steel or impact rollers.

Equal Idlers



- **Troughing idlers typically contain three rolls** with wing roll inclinations of 20, 35 or 45 degrees.
- **Support the conveyor belt and provide a trough** to contain the material conveyed.
- **The trough configuration** prevents spillage and increases the carrying capacity of the conveyor belt.
- **Standard equal idler spacing** is 3.5 to 4 feet apart .
- **Martin equal idlers meet or exceed the load carrying limits created by CEMA** (Conveyor Equipment Manufacturer's Association.)

Self-Aligner Idlers



- **Training idlers assist in training the belt and protect belt edges** from damage caused by misalignment
- **Transient conditions occur that may cause belts to become misaligned** such as build up on return rollers, poor Idler alignment, crooked structure and improper loading of material onto the belt.
- **On long conveyors, they are typically spaced 100 ft apart**, but should not be spaced within 50 feet of the head or tail pulleys.
- **The Idler frame is designed** to allow the Idler to swivel on the cross-member when the belt touches either guide roll.
- **Center roll slightly higher** to assist in pivoting assembly.

Returns



- **Return idlers support and carry the empty belt on the return side.**
- **Return idlers are typically spaced every 8 to 10 feet.**
- **Steel rolls are used in clean belt environments** or can be urethane-coated to protect the roll in abrasive/corrosive environments.
- **Rubber tread rolls are used when wet or sticky materials** cling to the belt and where corrosive or abrasive material will degrade the steel roll.
- **Spaced rubber disc rollers use massed rubber on both ends to support edges of belt.** You need enough flat surface in case belt mistracks and drops into spacer and cannot track back.
- **1½" and 4½" drop brackets.**
- **Belt-saver brackets are also available.**

Channel Inset Idlers



Channel inset idlers mount down inside a channel frame or vertical mounting surface and bolt horizontally. The low profile design is often used on portable equipment where reducing height is critical. Channel inset idlers are available in steel and impact designs.

Flat Carry Idlers



Flat carry idlers are used with flat belts where a trough is not required to contain material. They are used for picking, sorting, feeding or plowing material from the belt.

Live Shaft Idlers



Live shaft idlers are provided with pillow block bearings. They are typically used in feeder applications or applications with higher belt tensions not suitable for conventional flat rollers with internal bearings. Live shaft idlers are available in impact, spaced rubber disc and steel configurations.

Heavy-Duty Conveyor Pulleys

Face **C** **MES** **18** **36** **X25** **L** **3** **H** **Lagging Style**

C Crown If no letter, lagging is smooth

F Flat **H** Herringbone

Pulley Type **C** **S** **W** **120** **26** **X25** **D** Diamond Groove

MES Profiled End Disc Pulley **C** Ceramic (no thickness specified)

S Standard **S** Slide Lagging

M Mine Duty

Q Quarry Duty

QAR Quarry Duty AR

Pulley Style (Leave blank for Profiled End Disc Pulley)

D Drum

W Wing

CF Clean Flight®

Diameter 3 digits for most pulleys, 2 digits for Profiled End Disc Pulley.

Face Width 2 digits in inches

Lagging Thickness in 8th, 1 digit

Lagging add "L" if lagged

Bushing Part Number

Conveyor pulleys SHOULD use SHORT QD bushings and Profiled End Disc Pulleys will handle any MXT bushing

X25, X30,... MXT Bushing

SF, E, F, J,... QD Bushing

6207, 6315,... Keyless Locking Device

6 = Series (B106), 315 = Bushing Bore

Engineered Class Conveyor Pulleys

Engineered Mine Duty, Turbo Disc and T-Bottom

F **TB** **30** **076** **2** **220** **16** **Rim Thickness** in 16th, 2 digits

Bore (Metric or Standard) 3 digits

Last Digit of Keyless Locker

Face Width 3 digits

Diameter 2 digits

Pulley Type

EM Engineered Mine Duty **TD** Turbo Disc **TB** T-Bottom

Face

C Crown **F** Flat

Dead Shaft Pulleys

C **DS** **D** **20** **042** **B** **515** **Bearing Bore** in 16th, 3 digits

Bearing (B) or Piloted Flange (P)

Face Width 3 digits

Diameter 2 digits

Pulley Type

D Drum **W** Wing

Pulley Type

DS Dead Shaft

Face

C Crown **F** Flat

Idlers

CEMA Class (C, D, E) **C** **5** - **10** **V** **4** **G** - **36** - **09** **Wall Thickness Gauge** Only Steel Rolls (09, 07, 04)

Roll Diameter (4, 5, 6, 7)

Angle (Not for Return and Flat Carry)

10° V-Return **15°** Inverted V-Return **20°, 35°, 45°** Idler

Idler Type

Carry Side **Return Side**

T Equal Steel Idler	R Steel Return**
TI Equal Impact Idler	RRD Rubber Disc Return**
TSA Equal Steel Self-Aligner	URD Urethane Disc Return**
TSS Equal Steel Self-Aligner Shoe-Type	RSA Steel Return Self-Aligner*
U Unequal Steel Idler	RSS Steel Return Self-Aligner Shoe-Type*
UI Unequal Impact Idler	RRDSA Rubber Disc Return Self-Aligner*
CT Steel Channel Inset Idler	CR Steel Channel Inset Return**
CTI Impact Channel Inset Idler	CRRD Rubber Disc Channel Inset Return**
F Steel Flat Carry**	V Steel V-Return*
FRD Impact Flat Carry**	VRD Rubber Disc V-Return*
FSA Steel Flat Carry Self-Aligner	IV Steel Inverted V-Return
LI Impact Live Shaft Roll	IVRD Rubber Disc Inverted V-Return
	LR Steel Live Shaft Roll
	LRRD Rubber Disc Live Shaft Roll

Special Construction

A Grain Idler	R Removable Wing Bracket Idler
B Box Frame Idler	RET Retractable Idler
C Catenary Idler	TT Adjustable/Transitional Idler
G Galvanized Frame	W Wide Base Idler
L Urethane-Lagged Rolls	WR Wire Rope Idler
Q Scale Quality Idler	TO Offset Center Roll Idler

***Frame Rise/Drop for V, VRD, RSA, RRDSA**

1 1.5" Standard
4 4.5" Standard
4S 4.5" Belt Saver
7S 7" Belt Saver

****Bracket Rise/Drop for R, RRD, F, FRD**

Add the end of part number, examples:

C 5 - R - 36 - 09 - 4S

C 5 - FRD - 36 - 1

Shafting

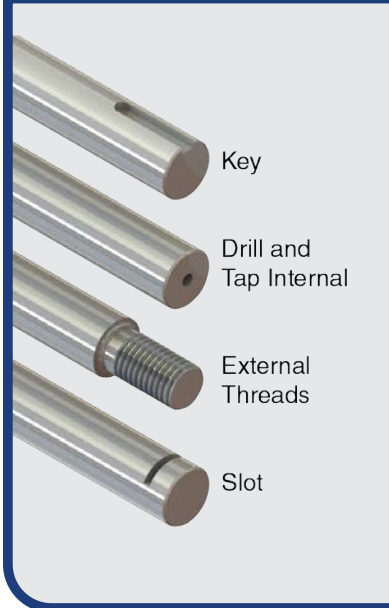

Martin has the inventory and machining capabilities for quick turnarounds on heavy-duty conveyor pulley shafts and custom shaft detailing for a wide variety of applications. Stock shafting is available for most applications on the shelf and ready to ship. For custom detailing, Martin offers on-site machining for customization, turndowns, customized keyways, and more.

- Shafts up to 24" diameter
- Shafts up to 22' long
- Raw bar weights up to 22,000 lbs.
- Stock shafting material available in several grades 1144 — 1045 — 4140 and Stainless Steel



Take-Up Frames

Martin's take-up frames are fabricated from steel, offering superior strength and durability in the most rugged conditions.

- Available in these styles:
 - Light duty
 - Top angle
 - Heavy duty
 - Center pull
 - Wide slot
 - Tube take-up
- Accommodate bearing shafts sizes from 1" to 5.9375"
- Available in standard travel lengths from 9" to 60"
- Stainless Steel, ACME thread and MTO lengths available
- Suitable for most manufacturers' housing styles including center pull wide slot, pillow block and top angle protected screw



Bearings

Martin offers a full line of roller bearings and stocks most common sizes. We can supply SAF, type E, and ball bearing units in pillow block, flange block, and take-up housing styles.

- Type E pillow block bearings
 - Bore range from 1-7/16" to 4-15/16" diameter
- Split housed spherical pillow block bearings
 - Stocked from 1-7/16" to 8" diameter



Martin's MXT® and MXT-STL® bushings are available from stock to fit all popular pulley sizes. Both styles are also available as weld-on hubs.

Both MXT® and MXT-STL® bushings offer a 2" per foot taper, which reduces end disc pre-stressing, as well as increasing clamping force.

Bushing Style **MXT H - STL 45*** **Bore Max Size**
 MXT *Martin* XT Example:
 M-HE *Martin* HE 45 4.5"

Weld-On Hub **MXT® Steel Option**
 Add H if its a Weld-On Hub Add -STL for Steel option, only for MXT (not for hub)

* NOTE: This part number does NOT reflect an actual part number, it includes all bushing/hub options only for instructional purpose.

Bushings and Weld-On Hubs

A conveyor belt system consists of at least 2 Pulleys, carrying and return Idler components, Take-Up components and a conveyor belt.

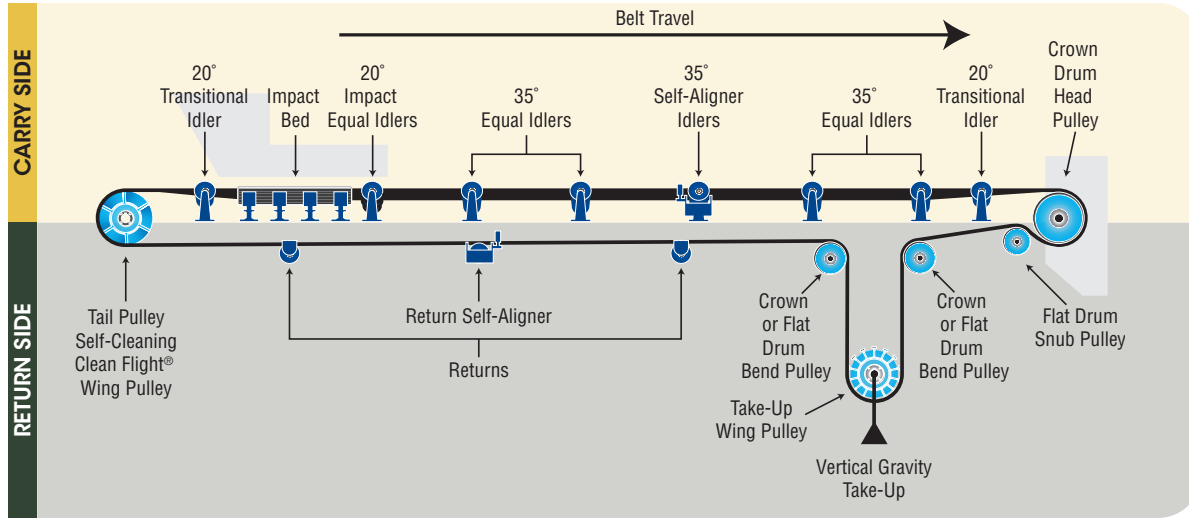

CARRY SIDE

Tail Pulley - A Pulley at the tail of the belt conveyor opposite the normal discharge end; may be a Wing Pulley, Clean Flight® Wing or Drum Pulley.

Transition Idler - Typically found on either end of the conveyor. These idlers have a smaller wing roll angle and help transition the conveyor belt to or from flat to full trough angle.

Impact Beds - Can be used at a material transfer point in place of impact idlers to help with material impact or conveyor sealing. Impact beds are able to handle a much heavier impact force. The replaceable impact bars are made of rubber with a UHMW cap to reduce conveyor belt drag.

Impact Idlers - Rubber disc help to absorb and dissipate impact forces without transferring it through the shaft, bearings, idler frames and conveyor structure. Impact idler frames are reinforced for added strength.

Equal/Unequal Idlers - Support the conveyor belt and provide a trough to contain the material conveyed.

Self-Aligning Idlers - Also known as training idlers are a solution for a mistracking belt. If the belt contacts the guide rollers or the self-actuating shoe the top of the idler pivots to steer the belt back into the trough.

Flat carry idlers - Some conveyors might require the belt to run flat for various needs like picking, sorting, or inspecting.

Head Pulley - The Pulley at the discharge end of a conveyor belt; may be either a non-drive or a drive Pulley. Usually it has a larger diameter than other Pulleys in the System and is often lagged to increase traction and Pulley life.

RETURN SIDE

Snub Pulley - Mounted close to the Drive Pulley on the return side of the belt, the Snub Pulley's primary job is to increase the angle of wrap around the Drive Pulley, thereby increasing traction. Its secondary purpose is reducing belt tension, which is important in maximizing conveyor component life. The Snub Pulley may be lagged for longer wear life.

Bend Pulley - The Bend Pulley is used for changing the direction of the belt running to the gravity take-up. It may be lagged for longer wear life.

Take-Up Pulley - A floating pulley with a counter weight to maintain adequate belt tension.

Return Idlers - Can be steel or spaced rubber disc. Typically mounted in drop brackets on the underside of the conveyor structure. The primary purpose of a return roll is to support the empty belt on the return side of the conveyor.

Return Self-Align Idlers - Mounted on the return side of the belt. Supports an empty flat belt. The assembly pivots if the return side of the belt begins to mistrack guiding the belt back into the center of the return rolls.

V-Return - 2 rolls typically in a 10 degree V assembly. The V profile aids with belt tracking. Should be used on higher tension systems and when steel cord belts are used in the application.

Inverted V-Return - Mounted on the inside of the belt to aid with belt tracking on the return side into the tail pulley.

Live Shaft Rollers - Steel, spaced rubber disc or feeder impact solid rubber disc mounted on external pillow block or flange bearings. Typically used in applications with excessive impact and material load or in areas of a conveyor belt with elevated belt tensions.

Martin Sales and Engineering will work with you to completely solve your belt conveying needs. Since there are infinite amounts of conveying possibilities and configurations our sales and Martin engineering staff are prepared to assist you with a custom solution.

Call Martin, we will be happy to assist you!



**Free Download
Maintenance &
Troubleshooting
Guide**

Scan to download



USA Corporate Offices Sales & Manufacturing

Arlington, TX
817-258-3000 (FAX 817-258-3333)

Regional Manufacturing Plants

Albemarle, NC
704-982-9555 (FAX 704-982-9599)
Atlanta, GA
404-292-8744 (FAX 404-292-7771)
Burleson, TX
817-295-7151 (FAX 817-447-3840)
Danielsville, PA
610-837-1841 (FAX 610-837-7337)
Ft. Worth, TX
817-258-3000 (FAX 817-258-3173)
Montpelier, OH
419-485-5515 (FAX 419-485-3565)
Sacramento, CA
916-441-7172 (FAX 916-441-4600)

Branch Manufacturing Plants

Charlotte, NC
704-394-9111 (FAX 704-394-9122)
Chicago, IL
847-298-8844 (FAX 847-298-2967)
Denver, CO
303-371-8466 (FAX 303-371-7116)
Houston, TX
713-849-4330 (FAX 713-849-4807)
Kansas City, MO
816-231-5575 (FAX 816-231-1959)
Los Angeles, CA
323-728-8117 (FAX 323-722-7526)
Minneapolis, MN
952-829-0623 (FAX 952-944-9385)
Nashville, TN
615-871-4730 (FAX 615-871-4125)
Portland, OR
503-223-7261 (FAX 503-221-0203)
Tampa, FL
813-623-1705 (FAX 813-626-8953)

Manufacturing Only

Abilene, TX • Clarksville, TX
Dallas, TX • Mansfield, TX
Paragould, AR

CANADA

Cambridge, Ontario
519-621-0546 (FAX 519-621-4413)
Edmonton, Alberta
780-450-0888 (FAX 780-465-0079)
Mississauga, Ontario
905-670-1991 (FAX 905-670-2110)

MEXICO

Guadalajara, JAL
+52 33-3283-1188
(FAX +52 33-3271-8450)
Monterrey, N.L.
+52 811 156 6830
(FAX +52 81-1156-6833)
Toluca, MEX
+52 722 276 0800
(FAX +52 722-276-0801)

BRAZIL

São Paulo, SP
+55 19 3877 9400
(FAX +55 19-3877-9429)

martinsprocket.com