



*Martin*

**GEAR  
MANUAL**

# GEAR MANUAL

Published by

*Martin* Sprocket & Gear, Inc.

Dave Walton, Technical Advisor

# TABLE OF CONTENTS

Introduction	1	Worm and Worm Gears	24
Work	2	Worms	24
Power	2	Worm Gears	24
Horsepower	2	Trigonometric Formulas	25-27
Mechanical Advantage	2	Pitch	28
Torque	2	Efficiency	30
Simple Machines	2	Self Locking	30
Levers	2	Formulas for Worm Gears	31
Wheel & Axle	2	Bevel Gears	32
Pulley	3	Mounting Distance	33
Incline Plane	3	Bevel Gear Nomenclature	34
Screw	3	Relative Rotation Thrust	34
Wedge	4	Bevel & Miter Gear Ratings	35-36
Torque to Horsepower	4	Direction of Thrust	36
Radian	4	Miter Gears	38
Gear Drives	5	Horsepower Ratings	39
History	5	Steel	39
Lubrication	6	Helical Gears	40
Involute Curve	7	Parallel Shafts	41
Pressure Angle	7	Pitch	42
Rotation	7	Approx. Ratings of HP transversed DP	
Principles of Gears	7	Helical Gears on Parallel Shafts	43-44
Types of Gears	7	Gear Tooth Wear and Failure	45
Shaft Centers Parallel	7	Surface Deterioration	45
Spur Gears	7	Normal Wear	45
Helical Gears	8	Abrasive Wear	45
Herringbone Gears	8	Scratching	45
Internal Gears	8	Overload	45
Shaft Centers Not Parallel	9	Ridging	45
Bevel Gears	9	Plastic Yielding	45
Miter Gears	9	Rolling & Scuffing	45
Spiral Gears	9	Peening	45
Hypoid Gears	10	Rippling	45
Worm Gears	10	Welding	45
Rack & Pinion Gears	10	Slight Scoring	46
Parts & Nomenclature	11	Severe Scoring	46
Pitch Circle	11	Surface Fatigue	46
Pitch Diameter	11	Initial Pitting	46
Pitch (Diametral Pitch)	11	Destructive Pitting	46
Circular Pitch	12	Electrical Pitting	46
Addendum	12	Spalling	46
Dedendum	12	Corrosive Wear	46
Working Depth	12	Burning	46
Whole Depth	12	Interference	46
Clearance	12	Grinding Checks	47
Ratio	12	Tooth Breakage	47
Rotation	13	Overload Breakage	47
Backlash	13	Fatigue	47
General Formulas	13	Cracking	47
American Stub Tooth Calculations	14	Glossary	48-50
Fellows Stub Tooth	14	Spur Gear Data Sheet	51
American Standard	14	Rack Gear Data Sheet	52
American Stub	14	Bevel Gear Data Sheet	54
Fellows Stub	14	Miter Gear Data Sheet	54
Spur Gear Dimensional Formulas	15	Worm Gear Data Sheet	55
Horsepower & Torque Ratings	16-23	Helical Gear Data Sheet	56
		Index	57

### MECHANICAL POWER TRANSMISSION FUNDAMENTALS

Mechanical power transmission is a necessity because the available force can seldom be used in industrial applications without being transferred, reduced or adjusted.

Power transmission components must be applied and power transmitted to provide the speed and torque at the point of the load.

Three basic laws formulated by Issac Newton 300 years ago simplified the science of mechanics.

#### **FIRST LAW OF MOTION**

“A body at rest remains at rest, and a body in motion continues to move at a constant speed in a straight line unless compelled to change by some external force.” (This characteristic is called inertia. Both acceleration and deceleration require overcoming the inertia of an object.)

#### **SECOND LAW OF MOTION**

“The acceleration of a body is in the direction of, and proportional to, the force that produces it, and is inversely proportional to the mass of the body.” (This tells what happens when a force is applied to a moving body. The change which any force makes in the motion of a body depends on two things. One is the size of the force, and the other is the mass of the object. The greater the force, the greater the acceleration. The greater the mass the smaller the acceleration.)

#### **THIRD LAW OF MOTION**

“For every action there is an equal and opposite reaction.”

**FORCE:** The pressure of any body against another body. When the applied force exceeds the resistance of the objects, motion is the result. Force is measured in tons, pounds, ounces, grams, kilograms, etc.

### WORK:

When force moves a body a measured distance provided the motion is in the direction of the force.

$$W \text{ (work)} = \text{Force (lbs.)} \times \text{Distance (ft.)}$$

The energy of a body may be defined as the ability of a body to do work. The potential energy of a body is its ability to do work by virtue of its position or condition. Kinetic energy of a body is its ability to do work by virtue of its motion.

i.e. A clock's weights have potential energy equal to the work they can do by running the clock as they descend.

i.e. A flywheel on a punch press has kinetic energy which provides the work being done on each stroke of the press.

### POWER:

Rate of doing work or amount of work done per unit of time.

$$\text{Power} = \frac{\text{Work}}{\text{Time}} \quad \text{or} \quad \frac{\text{Force} \times \text{Distance}}{\text{Time}}$$

### HORSEPOWER:

With the development of the steam engine Watt had to have a common equalizer to compare the amount of power produced. Most of the engines were sold for mine pumping. Draft horses were used primarily to keep the mines pumped out. Watt experimented with horses and found one horse could lift 33,000 ft./lb. per minute continuously for a working day.

$$\text{Horsepower (HP)} = \frac{\text{Force (lb.)} \times \text{Distance (ft.)}}{33,000 \times \text{Time (min.)}}$$

$$\text{HP} = \frac{F \times \text{FPM}}{33,000} \quad \text{or} \quad \frac{F \times \text{Distance (per second)}}{550}$$

### MECHANICAL ADVANTAGE:

By using machines or mechanical devices, a smaller force can be made to do the work of a larger force.

$$\text{MA} = \frac{F_o \text{ (large force)}}{F_a \text{ (small force)}}$$

Since we do not get something for nothing, the smaller force must act through a greater distance than the larger force.

### TORQUE:

The twisting or turning effort around a shaft tending to cause rotation. Torque is determined by multiplying the applied force times the distance from the point where force is applied to the shaft center.

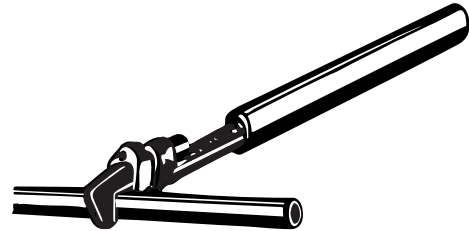

$$TQ = F \text{ (force)} \times R \text{ (Radius)}$$

### SIX BASIC SIMPLE MACHINES

1. Lever\*
2. Pulley
3. Wheel & Axle
4. Inclined plane\*
5. Screw
6. Wedge

\* Six machines are actually only two types

### LEVERS:

There are three classes of levers depending on the position of the fulcrum.

**Case 1:** The fulcrum is between the force or effort, and resistance.

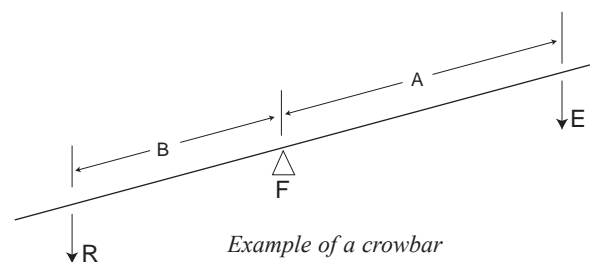

**Case 2:** The fulcrum is on the end and the resistance is between the fulcrum and the force.

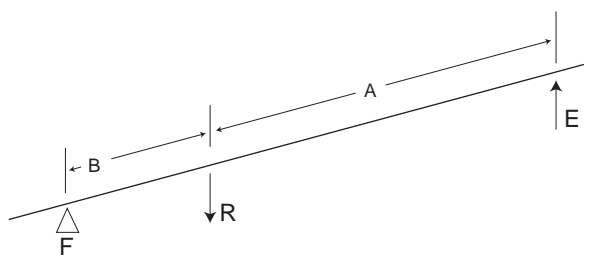

*Example of a wheel barrow*

**Case 3:** The force is applied between the fulcrum and the resistance.

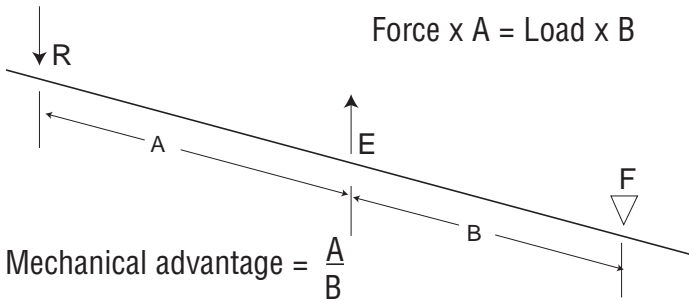

*Example of tweezers or arms.*

In Case 1 and Case 2 the force needed to move the object is less than the weight of the object. Lifting ability is gained at the expense of speed. In Case 3 the force must be greater than the weight of the object being moved. The gain is one of speed.

### WHEEL AND AXLE:

The greatest event of power transmission history was the invention of the wheel. With the wheel came the invention of the pulley.

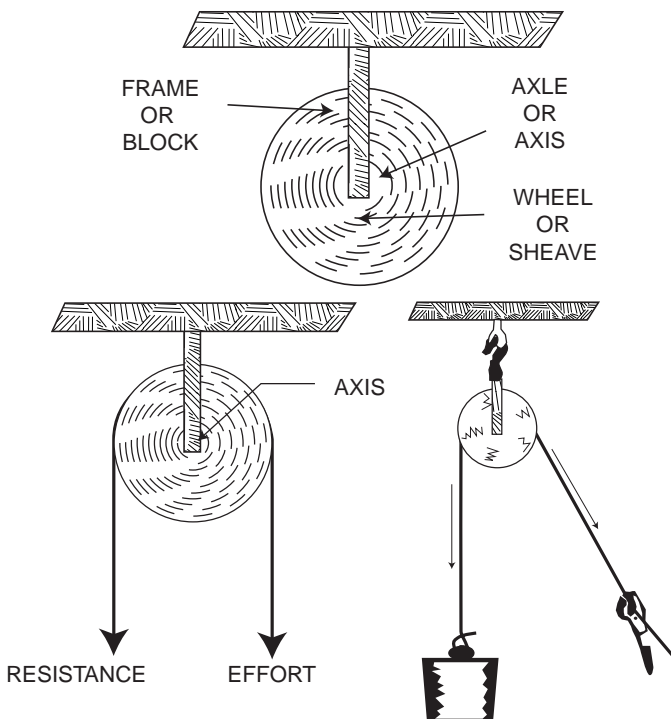

### PULLEY:

The first kind of pulley was the fixed pulley. It has no mechanical advantage, it only changes the direction of force.

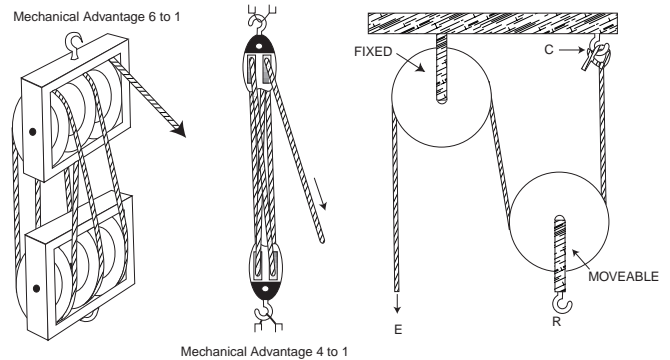

The second kind, by adding a moving pulley, cuts the effort in half to do the required work. The mechanical advantage is equal to the number of strands actually pulling the weight.

### INCLINED PLANE:

The mechanical advantage is the length of the incline divided by the vertical rise.

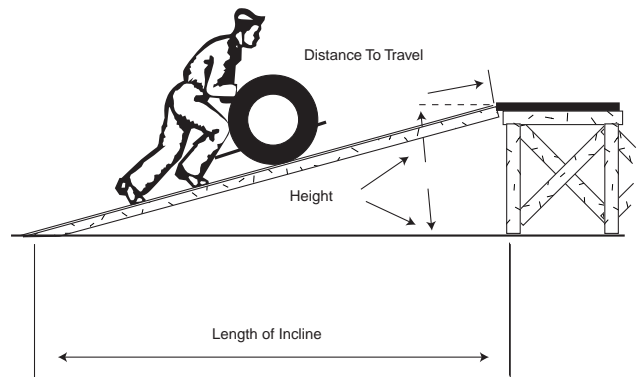

$$\text{FORCE} = \text{Load} \times \frac{\text{Length of Incline (LI)}}{\text{Height (H)}}$$

### SCREW:

A form of inclined plane. The mechanical advantage is the ratio of the circumference of the screw to the distance that the load advances during one revolution.

$$F = \frac{\text{Load}}{2 \pi r \times \text{Pitch}}$$

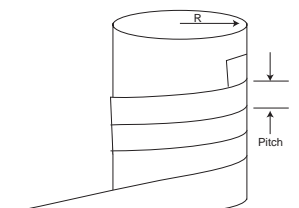

## INTRODUCTION

### WEDGE:

Another form of inclined plane.

### RELATIONSHIP OF TORQUE TO HORSEPOWER

$$TQ \text{ (in/lb)} = \frac{HP \times 63025}{RPM} \quad \text{or}$$

$$HP = \frac{TQ \text{ (in/lb)} \times RPM}{63025} \quad \text{or}$$

$$HP = \frac{TQ \text{ (ft/lb)} \times RPM}{5252} \quad \left( \text{i.e. } \frac{63025}{12} = 5252 \right)$$

$$TQ \text{ (ft/lb)} = \frac{HP \times 5252}{RPM}$$

To figure percent of loss or gain:

$$\text{Loss} = \frac{\text{Original number} - \text{new number}}{\text{Original number}} \times 100 = \%$$

$$\text{Gain} = \frac{\text{New number} - \text{Original number}}{\text{Original number}} \times 100 = \%$$

To find the circumference of a circle:

$$C = \text{Diameter} \times \pi \quad (\pi = 3.1416)$$

### DEFINITION OF RADIAN

The angle of the radius of a circle scribed on an arc of the circumference. A radian is 57.3°. It takes 6.28 radians to make a complete circle.

- s = Surface of arc
- r = Radius of circle
- Ø = Radians
- S = r Ø

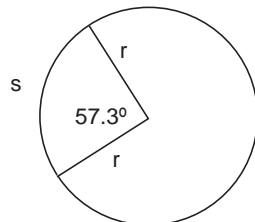

*NOTE: By definition work is equal to force times distance on a circle.*

To convert use  $W = F \times D \times T$  to circular  
 Work = Force  $\times \pi$  (D)  $\times$  RPM

### Sample Problem:

Find the work involved in a sprocket drive when a sprocket has a 12" pitch diameter with a chain force of 500 lbs. turning 150 RPM. Also find the work, linear velocity, and horsepower needed to turn this RPM.

$$W = F \times D$$

$$W = F \times \pi \times d \times RPM$$

$$W = 500 \text{ lbs.} \times 3.1416 \times 12 \text{ in.} \times 150$$

$$W = 235,620 \text{ ft/lb}$$

OR

$$W = F \times D$$

$$W = F \times \pi \times d \times RPM$$

$$W = 500 \text{ lbs.} \times 3.1416 \times 12 \text{ in.} \times 150$$

$$W = 2,827,440 \text{ in./lbs.}$$

D = Distance Traveled  
 d = Diameter  
 F = Force  
 R = radius

$$HP = \frac{\text{Torque} \times RPM}{63025} \quad (\text{Torque} = \text{Force} \times \text{Radius})$$

$$HP = \frac{F \times R \times RPM}{63025}$$

$$HP = \frac{500 \times 6 \times 150}{63025}$$

$$HP = 7.14$$

$$V = .262 \times d \text{ (in. inches)} \times RPM$$

$$V = .262 \times 12 \times 150$$

$$V = 471.60 \text{ ft./min.}$$

OR

$$V = 3.1416 \times d \text{ (in. ft.)} \times RPM$$

$$V = 3.1416 \times 12 \times 150$$

$$V = 471.24 \text{ ft./min.}$$

$$.262 = \frac{\pi}{12} = \frac{3.1416}{12} = .2618$$

### GEAR DRIVES

The earliest known relic of gearing was the "South Pointing Chariot" around 2600 B.C. This chariot was not only geared but it contained a very complex differential gear train. The Chinese apparently used this chariot to keep from getting lost while traveling through the Gobi Desert. It could be set so the figure points to a direction and continues to point to that direction regardless of the direction the chariot is turned.

Writings of Philo of Byzantium indicated that the prayer wheel devices found in Egyptian temples used gear trains for their operation and it seems probable that the Egyptians and Babylonians used gear devices as far back as 1000 B.C. The gear art had progressed to using both metal and wooden gears, triangular teeth, buttressed teeth and pins as teeth by 100 B.C. Spur gears, racks and pinions, worm gears, and right angle pin tooth gear drives were in use.

The Roman Empire around 16 A.D. to 100 A.D., boasted of using gears to drive saw mills, grist mills, saw marble from quarries, run clocks, operate astronomical devices, and measuring speed and distances. Iron came into use as the principle gear material and it is also possible gears were carburized and hardened during this period.

After the fall of Rome, there was a Dark Age of learning in Western Europe. Many devices and learning were destroyed or lost. The center of learning then shifted to the Arabic world where mathematics and mechanical arts were already being stressed. The Arabic world was fast becoming the leader in learning and the gear art was being stressed.

A replica of an Arabic geared calendar made sometime near 1221 or 1222 A.D. shows the use of triangular teeth on the drive gears. This calendar is a marvel of ingenuity and is more accurate than the Julian calendar we use to this day.

By the Fifteenth century, learning transferred back to Europe with such brilliant men as Leonard Da Vinci (1452-1519) of Italy. He designed many new and different machines such as his "Battle Car" the forerunner of the modern military tanks, guns and cannons. He developed a clock work automobile that actually worked and designed the predecessor of our helicopters.

During this time Da Vinci developed differential gear drives and even modern looking roller chains. However, gears made in Medieval times were nothing but crude wheels with square teeth of pin wheel gears running with barrel gears. These gears were used to power mills from water paddles or animal power. The knowledge of Rome slowly found its way back to Western Europe, but in all it did not go much beyond the Romans of over a thousand years earlier.

Nicholas of Cusa, a Frenchman, in 1451 A.D. studied the cycloidal curve that was later developed into gearing by Philip de Hire in 1694. He developed the involute curve for gearing, but it was not used in practice for about another 150 years. Abraham Kaestner, a German, in 1781, wrote about the practical methods for computing tooth profiles of involute curves. He considered a 15 degrees pressure angle the minimum for practical uses.

In 1832, an Englishman by the name of Robert Willis developed the standard of 1.0 divided by the diametral pitch as the standard gear addendum which is still used today. He also introduced the standard pressure angle of 14-1/2 degrees because it had a sine very close to .250.

This standard of 14-1/2 degrees was the only pressure angle up until the advent of World War II, when increased demand for higher horsepower meant redeveloping a new pressure angle. Then the 20 degree pressure angle was developed. There are still many gears made in either pressure angle

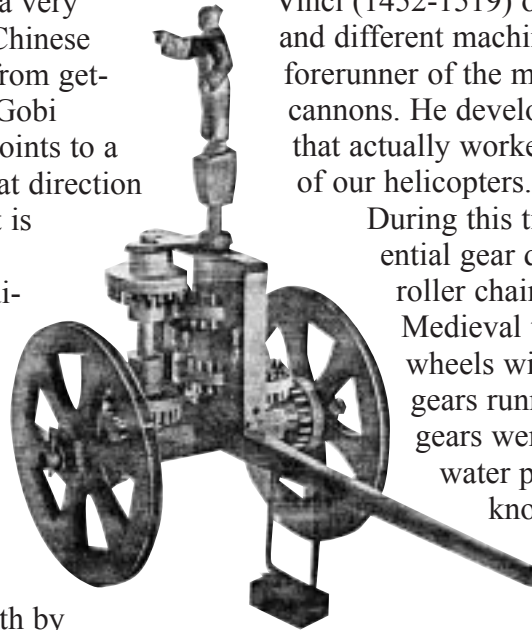

*South Pointing Chariot, circa 2600 BC. Courtesy of Smithsonian Institution, Washington, D.C.*

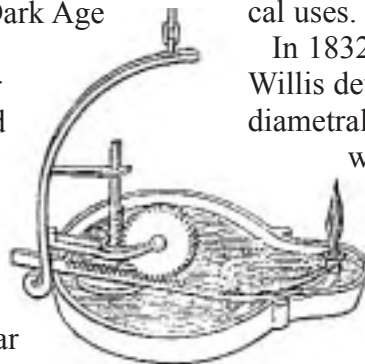

*Ingenious Roman lamp with self adjusting wick; racks are iron.*

system. The main thing to remember about the two systems is that they will NOT run together.

After World War II and the development of the two pressure angle systems, the American Gear Manufacturers Association was formed by the gear manufacturing companies to develop a system for standardizing gears being manufactured. Initially they came up with a standard of seven quality classes to be used. Four classes of “commercial” gears and three of “precision” gears. These standards did not include any material specifications. These early attempts did not satisfy the need for more precise gears in specialized applications.

In December of 1958 Lou Martin, a well-known gear expert and committee member of several AGMA committees, proposed enlarging the early standards. He envisioned expanding the standard to 15 classes of gears, from the “commercial” to the “ultra-precision”. The names were dropped and a code number system was adopted in October, 1959. The AGMA committee developed a new standard containing 16 class quality ranges applicable to coarse pitch, as well as fine pitch, spur, helical and herringbone gears. The AGMA included in this standard (AGMA 390.1) backlash specifications, eccentricity specifications, and materials.

*Martin* Sprocket & Gear, Inc. produces gears in the class 6 to class 8 range, which is comparable to the old commercial 1, 2 and 3 gears.

*Martin* has been making 20 deg. and 14-1/2 deg. P.A. gears since 1964, when we began the manufacturing of gears. We only stocked 14-1/2 deg. P.A. gears until 1991, when we added the most complete line of P.A. stock gears in the market.

Our 14-1/2 degree P.A. gears have S or C prefix in their part number for steel or cast iron. The 20 degree gears have TS or TC as prefix and have a wider face width than 14-1/2 degree They may be exchanged system for system, but not interchanged gear for gear as 14-1/2 degree gears WILL NOT RUN with 20 deg. gears.

### LUBRICATION OF GEARS

Most gears should be lubricated to extend the life of the gear set. AGMA has a complete standard for proper lubrication for open and enclosed gears. If in doubt - LUBRICATE.

In contrast to most enclosed gear trains, which are either flooded with lubricant or have external pumps to spray the mating gears with lubricant, open gears do not get the attention they deserve in being properly lubricated. To understand why this is important, as the gear tooth, comes into intimate contact with the mating tooth a film of lubricant between those surfaces is the only deterrent to metal wear or fatigue. At best, open gears may dip into an oil reservoir, thereby carrying a supply of oil to the meshing teeth. If the speed of the gears is excessive or the oil viscosity is too light, the supply of oil between the teeth may not be sufficient to prevent wear or gear tooth failure. Also, gears without covers allow dust and dirt to deposit on this wearing surface, greatly increasing the amount of wear on the teeth. A proper flow of oil will flush out these contaminants.

Under such conditions, lubrication depends largely upon the action which takes place between the oil and the metallic tooth surfaces. The thin films of lubricant must adhere to the tooth surfaces so that the contact of metal to metal is minimized. Most wear occurs during start up of the gears before these surfaces are coated and at oil break down.

Heat, by thinning the body of the oil, decreases the oil's resistance to being squeezed out from between the mating gear teeth. This acts to decrease the supply of oil remaining between the teeth. The thinner the oil becomes the less its bonding ability to the metal teeth. Increased temperatures decreases the oil's thickness as well as the resistance to being wiped off the tooth surfaces. In contrast, when gears operate under low temperatures the lubricant becomes thick and coats the tooth surfaces properly. Under these conditions a lighter, more free flowing oil would be preferred.

When gears are exposed to moisture, this exposes the gears to a washing action of water. The lubricant must be resistant to this action and remain on the teeth to prevent against wear and rusting. Possible additives to the basic lubricant may help this problem.

Lubricants correctly selected, applied, and of the proper viscosity will provide efficient service for

long periods. This will increase the life and performance of the gears. To measure the cost of the lubrication system, consider not just the price of oil but the expense of replacement of the entire gear train.

Reduced maintenance costs, lower power consumption and longer life of the gear set are the immediate benefits.

The viscosity of the oil varies with the ambient temperature. The following table should help you in the selection of proper non-detergent oil.

Ambient Temperature Degrees Fahrenheit	Non-Detergent Oil
20 - 40	SAE 20
40 - 100	SAE 30
100 - 120	SAE 40
120 - 140	SAE 50

## TYPES OF GEARS

### INVOLUTE CURVE:

The involute curve is developed by tracing a point on a cord as it unwinds from a circle.

*Involute curve*

*2 curves form tooth sides*

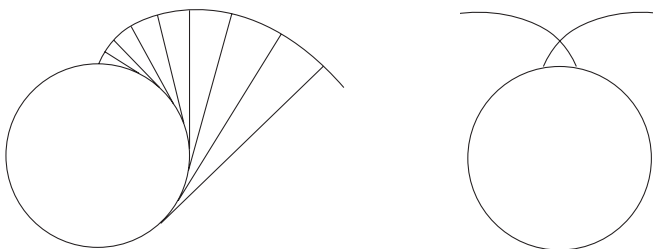

This tooth design reduces the sliding action of mating teeth thereby reducing friction and wear. It is formed by two involute curves drawn in opposite directions.

### PRESSURE ANGLE:

The angle between a tooth profile and the line tangent to a pitch surface, usually at the pitch

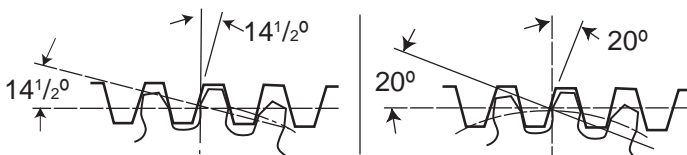

FIGURE 2

point on the tooth profile.

Gears are usually furnished with one of two pressure angles 14-1/2° or 20°. The most important thing to remember is that the gears cut in either pressure angle will only run with matching pressure angles. They will not run together or mesh correctly.

### ROTATION:

The shaft rotation of two mating gears will be reversed from driver to driven. With spur or helical gears an idler may be used to make driver and driven turn the same direction.

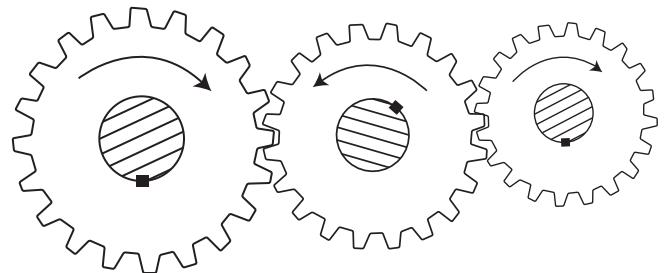

### PRINCIPLE TYPES OF GEARS

There are two categories, one for shafts whose centerlines are parallel and one for shafts not parallel.

## SHAFT CENTERS PARALLEL

### SPUR GEARS:

The shafts are in the same plane and parallel. The teeth are cut straight and parallel to the axis of the shaft rotation. No more than two sets of teeth are in mesh at one time therefore the load is rapidly transferred from one tooth to another. Most often used for moderate to low speeds. Normally used for more than 1100 FPM pitch line velocity!

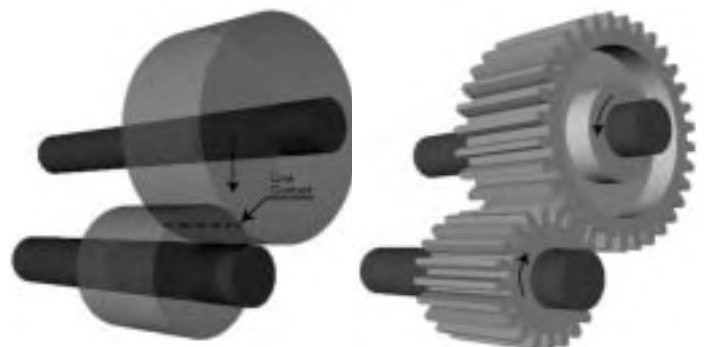

## GEAR MANUAL

### HELICAL GEARS:

The shafts are in the same plane and parallel but the teeth are cut at an angle to the centerline of the shaft. Helical teeth have an increased length of contact. Helicals run quieter and have a greater strength and capacity than spurs. Normally the angle created by a line through the center of the tooth and a line parallel to the axis of the shaft is  $45^\circ$ , although, other helix angles may be found. Tests were conducted and found that noise decreased with the helix angle being increased from  $0^\circ$  up to  $20^\circ$ ; at that point upward no noticeable improvement was observed. Usually for higher speed drives, maximum recommended 1800 FPM pitch line velocity.



### HERRINGBONE GEARS:

Commonly called double helical because they have teeth cut with right and left helix angles. They are used for heavy loads at medium to high speeds. They do not have the inherent thrust forces that are present in helical gears.



Herringbone gears have opposed teeth joined in middle.

Double helical gearing uses two pairs of opposed gears to eliminate thrust.

### INTERNAL GEARS:

These gears can be cut as either spur or helicals and are compact, smooth running and can provide high ratios. Internal gears can only be run with an external gear of the same type pitch and pressure angle.

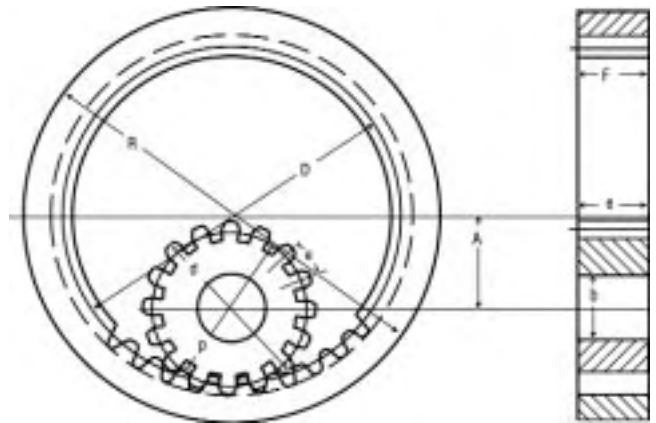

Simple Internal/External Mesh

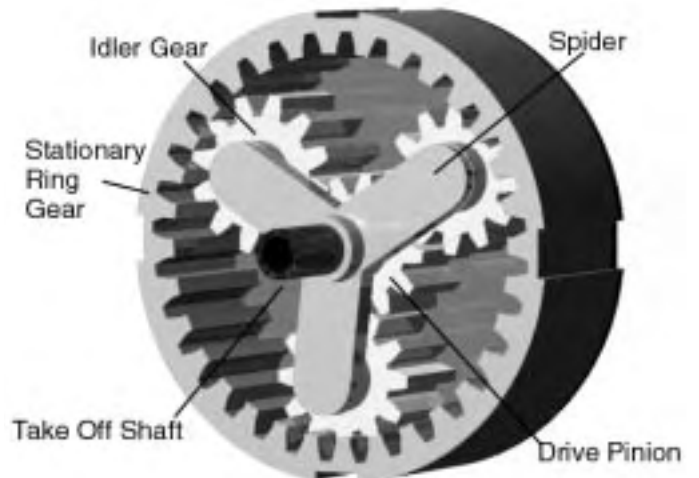

Planetary Gear Train with Driver, Driven & 3 Idlers

### SHAFT CENTERS NOT PARALLEL



### BEVEL GEARS:

Bevel gears transmit power and motion between shafts that are intersecting. These are cone shaped with tapered teeth, larger towards the outside tapering to smaller towards the center. Predominant usage is at 90° shaft axis to shaft axis.

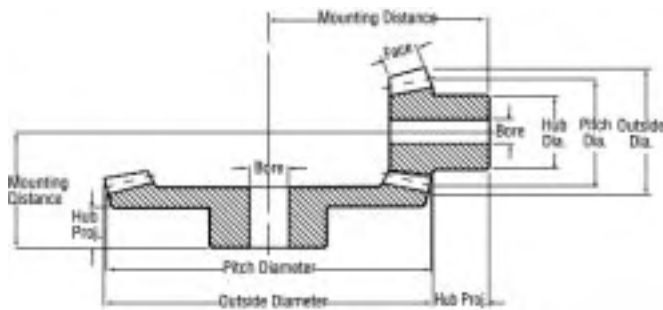

### MITER GEARS:

These are bevel gears that have 1 to 1 ratio and are always 90° shaft axis to shaft axis.

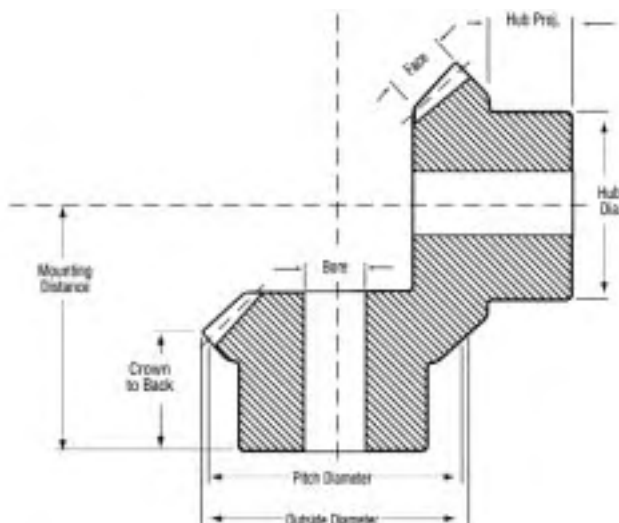

Pitch angle is the sum of the pitch lines extended which meet at a point called the apex. This sum is usually 90° but special gear sets can be manufactured for any angle up to 180°. The pitch angle on bevel gear pinions is determined by the number of teeth in the bevel gear. The pitch angle of the bevel gear is determined by the number of teeth in the bevel pinion. These gears are matched in manufacturing by the ratios as sets. These gears are designed to run with a specific mating gear. These gears should always be purchased in sets.

For coniflex bevel sets & miter sets maximum pitch line velocity should be 1100 FPM.

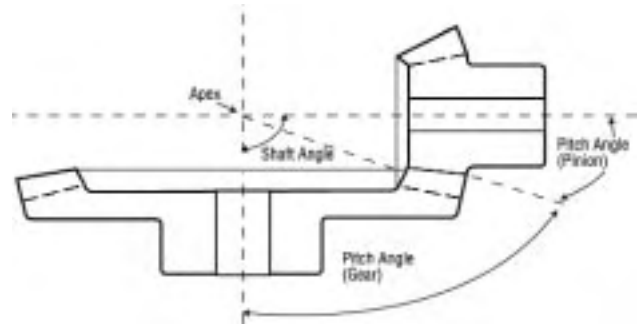

### SPIRAL BEVEL:

These are essentially the same as plain bevel gears except the teeth are cut in a spiral arrangement. These gears provide the same advantages as helicals do to plain spur gears. They are quieter and are capable of higher torque loads and speed (RPM).

The maximum recommended speed is 1800 FPM pitch line velocity.

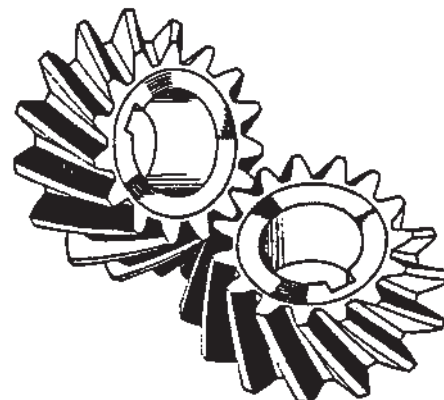

## SPUR GEARS

### HYPOID GEARS:

These are about the same as spiral bevel gears except that the pinion is not on the same plane and the shafts would do intersect. The prime use for these gears is for machinery where surrounding equipment would conflict with the drive shaft location. A good example is the car differential.

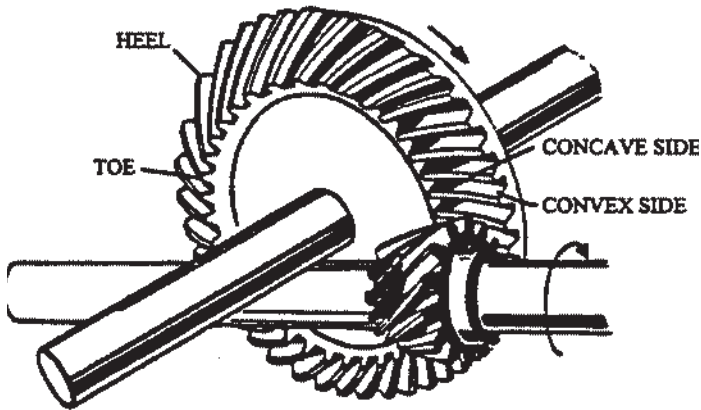

### WORM GEARS:

Worm gears are used for non-intersecting shafts at 90°. Uses a screw type worm turning a worm gear cut with a helix angle so the continuous action of the screw threads advance the gear. These gears allow high reduction in compact space.

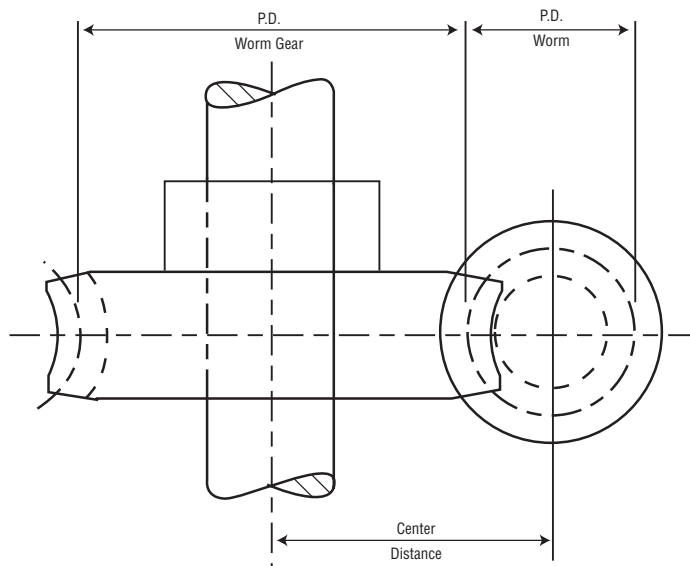

Worms and worm gears can be either right or left hand. These must also be obtained in sets specific to

leads or number of threads on gears, as well as right or left handed.

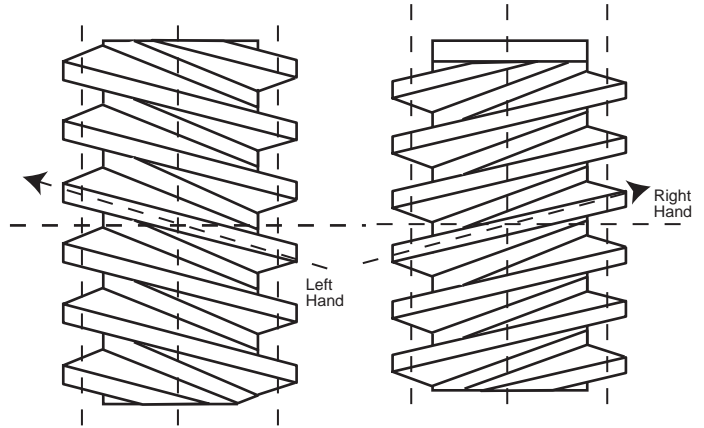

The number of threads on worms can be determined by looking at the end of the worm and counting the number of starts.

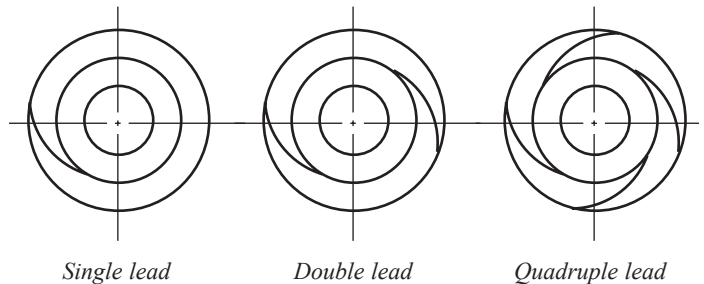

### RACK & PINIONS:

Rack & pinions change rotary motion to linear motion or linear motion to rotary motion. The rack is a straight bar with either straight or helical teeth cut across one side the same pitch as the pinion gear. The pinion is a standard spur or helical gear to mesh with the rack.

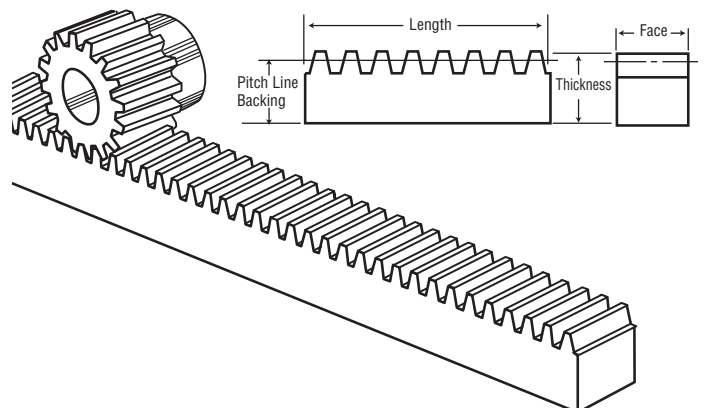

### SPUR GEARS

#### PARTS AND NOMENCLATURE

##### PITCH CIRCLE:

The imaginary line which passes through the center of each tooth on the gear.

##### PITCH DIAMETER:

The straight line measurement from one point on the pitch circle through the center to another point on the pitch circle.

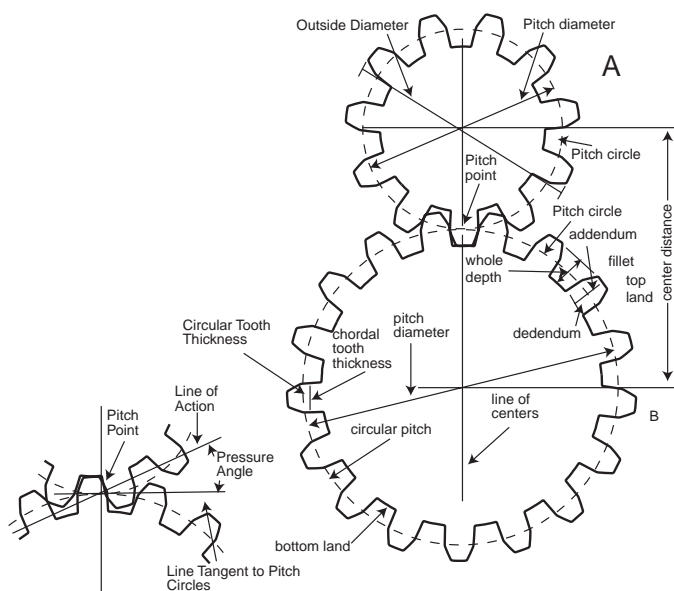

##### PITCH:

Refers to the diametral pitch, which is the ratio of the number of teeth to the pitch diameter. Is almost always expressed as a whole number. It also signifies the relative size of the teeth. The smaller the number the larger the size of the teeth. Conversely, the larger the number the smaller the teeth.

*For example:*

A gear has a P.D. of 10" and has 40 teeth.

$$\frac{40}{10} = 4 \text{ DP gear}$$

OR

A gear has a P.D. of 10" and has 120 teeth.

$$\frac{120}{10} = 12 \text{ DP gear}$$

#### Comparative Sizes of Involute Gear Teeth

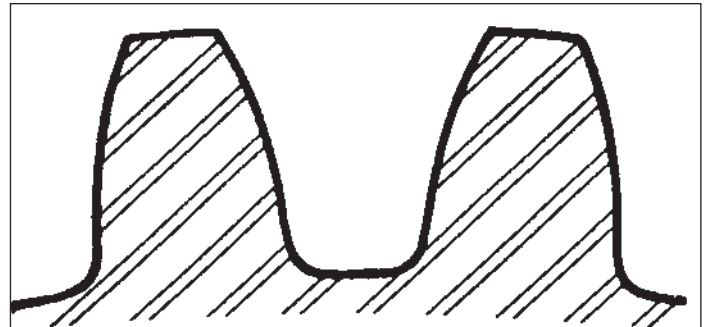

1 1/4 Diametral Pitch - 1.7952" Circular Pitch

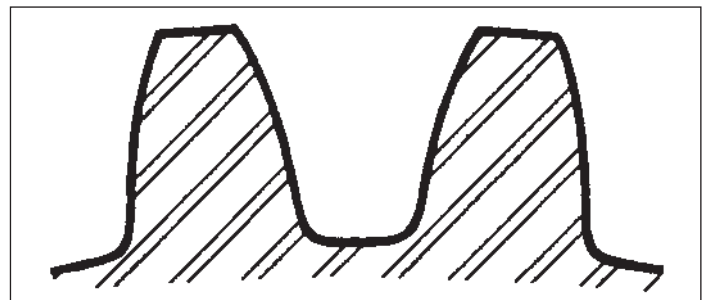

2 Diametral Pitch - 1.5708" Circular Pitch

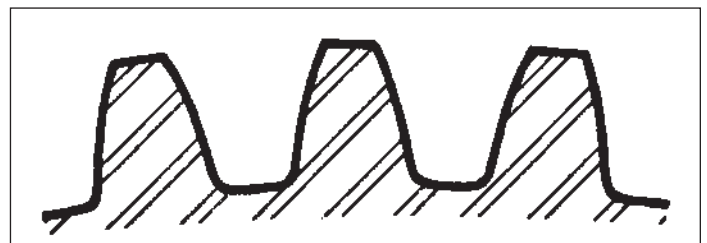

2 1/2 Diametral Pitch - 1.2566" Circular Pitch

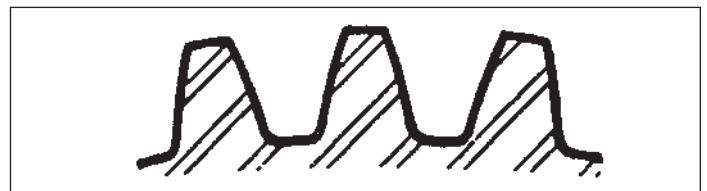

3 Diametral Pitch - 1.0472" Circular Pitch

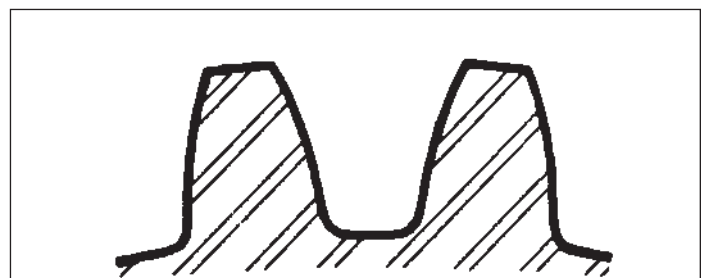

3 1/2 Diametral Pitch - .8976" Circular Pitch

## SPUR GEARS

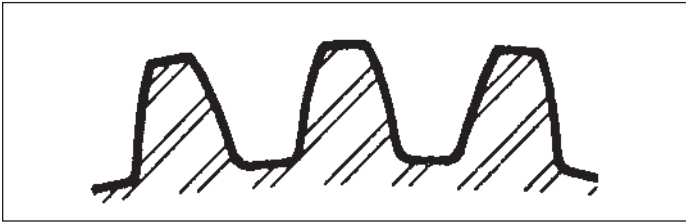

4 Diametral Pitch - .7854" Circular Pitch

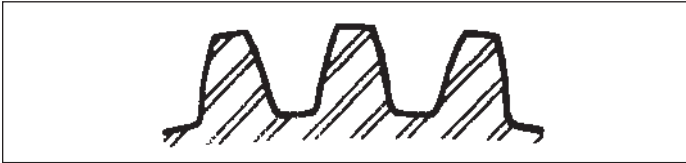

5 Diametral Pitch - .6283" Circular Pitch

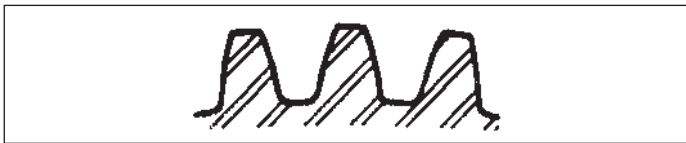

6 Diametral Pitch - .5236" Circular Pitch

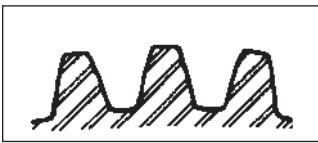

7 Diametral Pitch  
.4488" Circular Pitch

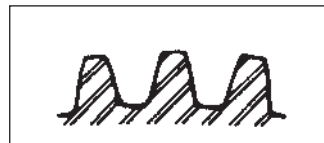

8 Diametral Pitch  
.3927" Circular Pitch

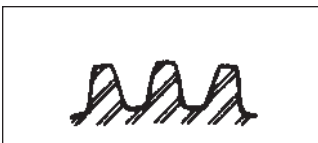

10 Diametral Pitch  
.3142" Circular Pitch

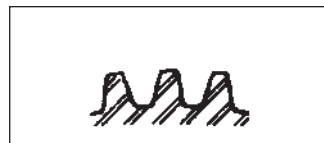

12 Diametral Pitch  
.2618" Circular Pitch

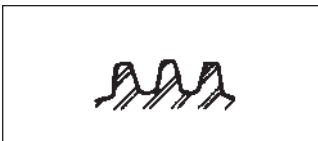

14 Diametral Pitch  
.2244" Circular Pitch

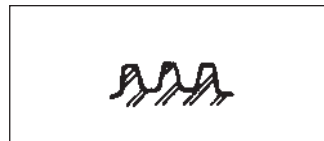

16 Diametral Pitch  
.1963" Circular Pitch

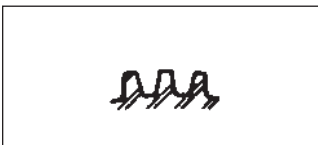

18 Diametral Pitch  
.1745" Circular Pitch

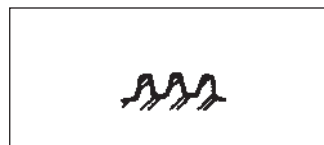

20 Diametral Pitch  
.1571" Circular Pitch

**CIRCULAR PITCH** is the distance in inches from a point on one tooth to the same point on another adjacent tooth measured along the pitch circle.

**ADDENDUM** is the portion of the tooth between the outside and the pitch circle.

**DEDENDUM** is the portion of the tooth between the pitch circle and the bottom of the tooth.

**WORKING DEPTH** is the depth of the two mating gears in proper engagement.

**WHOLE DEPTH** is the tooth depth or the sum of the addendum and the dedendum.

**CLEARANCE** is the difference between the addendum and the dedendum. Figured so the gear will ride on the pitch circle and not bottom out.

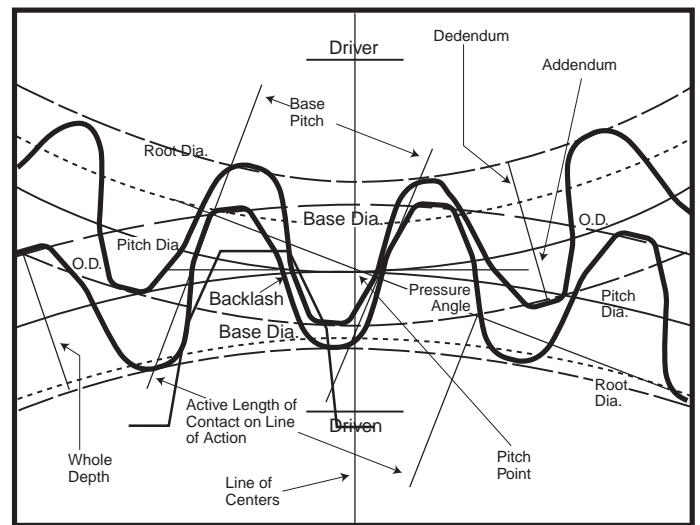

**RATIO** is the relationship of the number of teeth in one gear to the number of teeth of the other. Also the relationship of the respective pitch diameters.

$$\frac{\text{GEAR } 30 \text{ TEETH}}{\text{PINION } 15 \text{ TEETH}} = \frac{2}{1} \quad 2:1 \text{ Ratio}$$

$$\frac{\text{GEAR } 4\text{DP } 30}{\text{PINION } 4\text{DP } 15} = \frac{7.500 \text{ PD}}{3.750 \text{ PD}} = 2:1 \text{ Ratio}$$

Ratio of worm gears is determined by dividing the number of teeth on the worm gear by the number of threads on the worm.

For example:

W84ODR - Double thread  
 40 teeth      8 DP    Right Hand  
 $\frac{40}{2} = 20:1$     Ratio

**ROTATION** is normally reversed with even number of gears and in the same direction with odd number of gears.

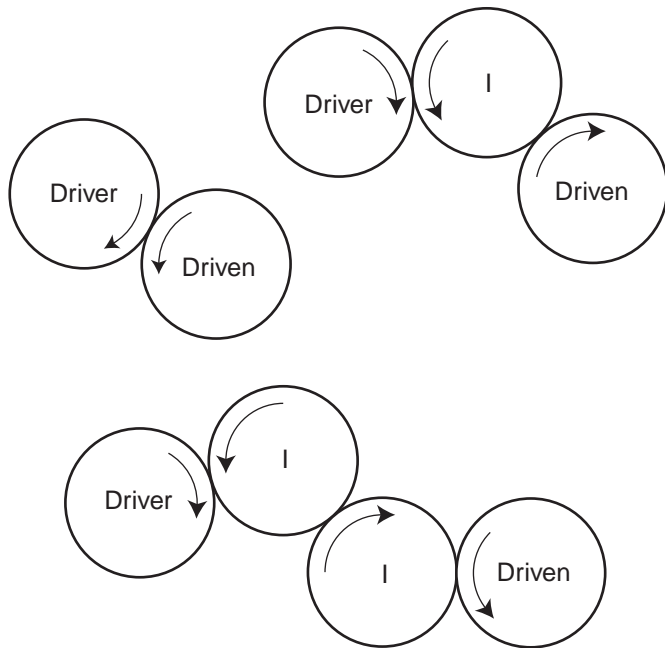

**BACKLASH** is an important factor in proper gear installation. A certain amount of backlash must be built into gear drive allowing for tolerances in concentricity and tooth form. Not enough backlash will cause early failure due to overloading, heat due to improper lubrication, binding and fatigue of tooth surfaces.

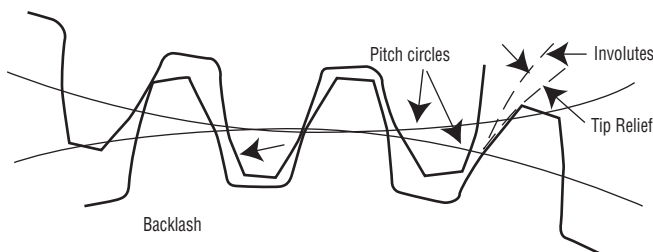

*Backlash and tip relief.*

### GENERAL FORMULAS

for finding various spur gear parts.

$$PD = \frac{Nt}{DP}$$

$$DP = \frac{Nt}{PD}$$

$$DP = \frac{Nt + 2}{OD}$$

$$Nt = PD \times DP$$

$$CD = \frac{PD(Dr) + PD(Dn)}{2}$$

$$A = \frac{1}{DP}$$

$$OD = \frac{Nt + 2}{DP}$$

$$D = \frac{1.157}{DP}$$

$$C = \frac{.157}{DP}$$

$$WD = \frac{2.157}{DP}$$

- C = Clearance
- Nt = Number of Teeth
- Dp = Diametrical Pitch
- PD = Pitch Diameter
- OD = Outside Diameter
- CD = Center Distance
- Dr = Driver
- Dn = Driven
- A = Addendum
- D = Dedendum
- WD = Whole Depth

*NOTE: The above calculations are for American Standard full depth involute tooth spur gears.*

## SPUR GEARS

$$D = WD - A$$

$$\text{Working Depth} = \text{ADD} \times 2$$

$$C = WD - 2 \times \text{ADD}$$

While some gears are cut with the standard hob type machines, you may encounter gears which have been cut with a shaper type machine. The gears cut with a shaper have slightly deeper teeth and the bottom of the teeth are not as flat as hob cut gears.

HOB CUT                  SHAPER CUT

$$WD = \frac{2.157}{DP}$$

$$WD = \frac{2.250}{DP}$$

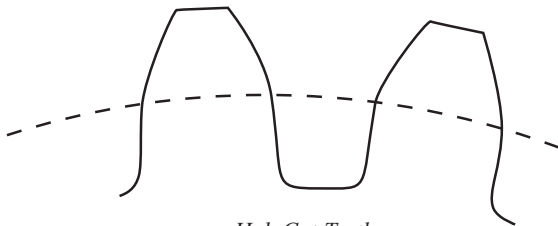

*Hob Cut Teeth*

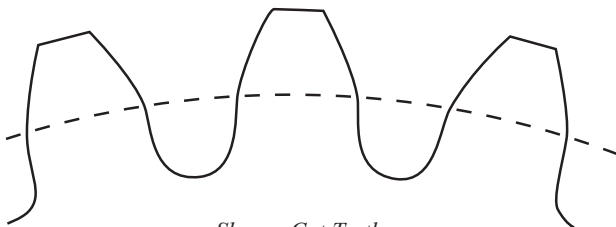

*Shaper Cut Teeth*

There are three other American Standard types known as Stub teeth. Two systems are widely used. One is the American Stub (20°) and the other is the Fellows Stub (20°).

### AMERICAN STUB TOOTH CALCULATIONS

$$PD = \frac{Nt}{DP}$$

$$CD = \frac{PD(Dr) + PD(Dn)}{2}$$

$$DP = \frac{Nt}{PD}$$

$$A = \frac{.8}{DP}$$

$$OD = \frac{Nt + 1.6}{DP}$$

$$D = \frac{1}{DP}$$

$$WD = \frac{1.8}{DP}$$

$$C = \frac{.2}{DP}$$

### FELLOWS STUB TOOTH

The DP is expressed as a fraction for example 3/4, 4/5, 5/7, 10/12, etc.

In the Fellows Stub tooth system, the numerator determines the pitch diameter only. The denominator determines the size and configuration of the teeth.

$$OD = \frac{Nt}{\text{Numerator}} + \frac{2}{\text{Denominator}} \frac{\text{NUMERATOR}}{\text{DENOMINATOR}}$$

$$OD = \frac{40}{4} + \frac{2}{5} = 10.000 + .400 = 10.400$$

### AMERICAN STD.

$$\begin{array}{ll} 4DP & 40T \\ 10.000 & PD \\ 10.500 & OD \end{array}$$

### AMERICAN STUB

$$\begin{array}{ll} 4 DP & 40T \\ 10.000 & PD \\ 10.400 & OD \end{array}$$

### FELLOWS STUB

$$\begin{array}{ll} 4/5 DP & 40T \\ 10.000 & PD \\ 10.400 & OD \end{array}$$

*NOTE: For most practical applications Fellows Stub gears may be substituted for American Stub.*

$$A = \frac{1}{DEN} = \frac{1}{5} = .200$$

$$D = \frac{1.25}{DEN} = \frac{1.25}{5} = .250$$

$$C = \frac{.25}{DEN} = \frac{.25}{5} = .050$$

$$PD = \frac{Nt}{NUM} = \frac{40}{4} = 10,000$$

$$WD = \text{ADD} + \text{DED} = .200 + .250 = .450$$

$$WD = \frac{2.25}{DEN} = \frac{2.25}{5} = .450$$

**SPUR GEAR DIMENSIONAL FORMULAS  
FOR FULL DEPTH INVOLUTE TEETH**

TO OBTAIN	HAVING	FORMULA
Diametral Pitch (DP)	Circular Pitch (CP)	$DP = \frac{3.1416}{CP}$
	No. Of Teeth (Nt) And Pitch Dia. (PD)	$DP = \frac{Nt}{PD}$
	No. Of Teeth (Nt) And Outside Dia. (OD)	$DP = \frac{Nt + 2}{OD}$
Circular Pitch	Diametral Pitch (DP)	$CP = \frac{3.1416}{DP}$
Pitch Diameter (PD)	No. Of Teeth (Nt) And Diametral Pitch (DP)	$PD = \frac{Nt}{DP}$
Number of Teeth (Nt)	Pitch Dia. (PD) & Diametral Pitch (DP)	$Nt = PD \times DP$
Tooth Thickness (TT) (@ Std. PD)	Diametral Pitch (DP)	$TT = \frac{1.5708}{DP}$
Addendum (Add)	Diametral Pitch	$Add. = \frac{1}{DP}$
Outside Diameter (OD)	Pitch Dia. (PD) And Addendum (Add)	$OD = PD + 2 \text{ Add.}$
Whole Depth (WD) (Coarser Than 20 DP)	Diametral Pitch (DP)	$WD = \frac{2.157}{DP}$ (Hobbed) $WD = \frac{2.25}{DP}$ (Shaped)
Clearance (CL)	Whole Depth (WD) And Addendum (Add)	$CL = WD - 2 \text{ Add.}$

# SPUR GEAR HORSEPOWER RATINGS



For  
Class I Service (Service Factor = 1.0)

## 4 Diametral Pitch

## 20° Pressure Angle

## 3½" Face

No. Teeth	25 RPM		50 RPM		100 RPM		200 RPM		300 RPM		500 RPM		600 RPM		900 RPM		1200 RPM		1800 RPM		
	S	CI	S	CI	S	CI	S	CI	S	CI	S	CI	S	CI	S	CI	S	CI	S	CI	
11	2.62		5.09		9.64		17.41		23.81		33.72		37.64		46.69		53.06				
12•	3.10		6.02		11.40		20.59		28.15		39.88		44.52		55.21		62.75				
13	3.62		7.03		13.30		24.03		32.86		46.55		51.97		64.45		73.25				
14•	4.07		7.91		14.98		27.06		37.00		52.41		58.51		72.57		82.48				
15•	4.57		8.88		16.80		30.35		41.51		58.80		65.64		81.41		92.53				
16•	4.97		9.67		18.30		33.05		45.20		64.03		71.47		88.64		100.75				
17	5.41		10.51		19.90		35.95		49.16		69.64		77.74		96.42						
18•	5.84		11.35		21.49		38.82		53.09		75.20		83.95		104.12						
19	6.29		12.22		23.13		41.77		57.13		80.93		90.33		112.04						
20•	6.74		13.11		24.81		44.81		61.29		86.81		96.91								
21	7.19		13.98		26.46		47.79		65.36		92.58		103.34								
22•	7.65		14.87		28.14		50.83		69.52		98.48		109.93								
24•	8.52		16.56		31.35		56.63		77.45		109.71		122.47								
25	8.96		17.41		32.95		59.52		81.39		115.30		128.70								
26	9.43		18.32		34.67		62.63		85.65		121.32		135.43								
27	9.90		19.24		36.42		65.79		89.97		127.45		142.27								
28•	10.39		20.18		38.21		69.01		94.38		133.69		149.24								
30•	11.32		22.00		41.63		75.20		102.84		145.69										
32•	12.27		23.85		45.15		81.56		111.54		158.00										
33	12.76		24.80		46.95		84.80		115.97		164.28										
35	13.79		26.81		50.74		91.66		125.35		177.56										
36•	14.30		27.79		52.61		95.03		129.96		184.10										
40•	16.40		31.87		60.32		108.95		149.00												
42	17.39		33.80		63.98		115.58		158.06												
44•	18.41		35.77		67.71		122.31		167.27												
45	18.92		36.77		69.60		125.72		171.93												
48•	20.54		39.91		75.54		136.46		186.61												
50	21.50		41.78		79.08		142.84		195.35												
52	22.52		43.77		82.85		149.65		204.66												
54	23.56		45.78		86.66		156.54		214.08												
55	24.00		46.63		88.26		159.44		218.04												
56•	24.49		47.59		90.09		162.73														
60•	26.62		51.73		97.92		176.87														
64•	28.60		55.57		105.19		190.01														
66	29.63		57.58		108.99		196.87														
70	31.65		61.50		116.41		210.27														
72•	32.55		63.26		119.73		216.28														
80•	36.76		71.43		135.21		244.23														
84	38.86		75.52		142.94		258.21														
88	40.80		79.30		150.09																
90	41.83		81.28		153.85																
96	44.92		87.29		165.23																
100	46.90		91.13		172.50																
108	50.87		98.87		187.14																
110	51.93		100.92		191.03																
112	52.88		102.76		194.50																
120	57.03		110.84		209.79																
144	54.18		105.28		199.28																
160	77.39		150.40		284.68																
200	97.58		189.64		358.95																

Ratings are based on strength calculation. Basic static strength rating, or for hand operation of above gears, is approximately 3 times the 100 RPM rating.

• Designates stock sizes for this pitch.

Note: 1. Ratings to right of heavy line are not recommended, as pitch line velocity exceeds 1000 feet per minute. They should be used for interpolation purposes only.

2. Non-metallic gears are most commonly used for the driving pinion of a pair of gears, with mating gear made of Cast Iron or Steel, where pitch line velocities exceed 1000 FPM and are not subjected to shock loads.



# SPUR GEAR HORSEPOWER RATINGS

For  
Class I Service (Service Factor = 1.0)

5 Diametral Pitch

20° Pressure Angle

2½" Face

No. Teeth	25 RPM		50 RPM		100 RPM		200 RPM		300 RPM		500 RPM		600 RPM		900 RPM		1200 RPM		1800 RPM	
	S	CI	S	CI	S	CI	S	CI	S	CI	S	CI	S	CI	S	CI	S	CI	S	CI
11•	1.20		2.35		4.50		8.28		11.49		16.67		18.78		23.82		27.50		32.54	
12	1.42		2.78		5.32		9.79		13.59		19.71		22.21		28.17		32.53			
13•	1.66		3.25		6.21		11.43		15.86		23.01		25.93		32.88		37.97			
14•	1.87		3.66		7.00		12.87		17.86		25.90		29.19		37.02		42.75			
15•	2.10		4.10		7.85		14.44		20.04		29.06		32.75		41.53		47.96			
16	2.29		4.47		8.55		15.72		21.82		31.64		35.66		45.22		52.22			
17•	2.49		4.86		9.30		17.10		23.73		34.42		38.79		49.19		56.80			
18	2.69		5.25		10.04		18.46		25.63		37.17		41.88		53.11		61.34			
19•	2.89		5.65		10.80		19.87		27.58		40.00		45.07		57.16		66.01			
20	3.10		6.06		11.59		21.31		29.58		42.91		48.35		61.31					
21	3.31		6.46		12.36		22.73		31.55		45.76		51.56		65.39					
22•	3.52		6.87		13.15		24.18		33.56		48.67		54.85		69.55					
24•	3.92		7.66		14.65		26.93		37.39		54.22		61.10		77.49					
25	4.12		8.05		15.39		28.30		39.29		56.98		64.21		81.43					
26	4.33		8.47		16.20		29.78		41.34		59.96		67.57							
27•	4.55		8.90		17.02		31.29		43.43		62.99		70.98							
28•	4.78		9.33		17.85		32.82		45.56		66.08		74.46							
30	5.20		10.17		19.45		35.76		49.64		72.00		81.14							
32	5.64		11.03		21.09		38.79		53.84		78.09		88.00							
33•	5.87		11.47		21.93		40.33		55.98		81.19		91.49							
35	6.34		12.40		23.70		43.59		60.51		87.76		98.89							
36•	6.58		12.85		24.58		45.19		62.73		90.99									
40	7.54		14.73		28.18		51.81		71.92		104.32									
42	8.00		15.63		29.89		54.96		76.30		110.66									
44•	8.46		16.54		31.63		58.17		80.74		117.11									
45	8.70		17.00		32.51		59.79		82.99											
48•	9.44		18.45		35.29		64.89		90.08											
50	9.89		19.32		36.94		67.93		94.30											
52	10.36		20.24		38.70		71.17		98.79											
54	10.83		21.17		40.48		74.44		103.34											
55	11.03		21.56		41.23		75.82		105.25											
56•	11.26		22.01		42.08		77.39		107.42											
60	12.24		23.92		45.74		84.11		116.76											
64	13.15		25.70		49.14		90.36		125.43											
66•	13.62		26.62		50.91		93.62		129.96											
70	14.55		28.44		54.38		100.00		138.81											
72•	14.97		29.25		55.93		102.85													
80	16.90		33.03		63.16		116.15													
84	17.87		34.92		66.78		122.79													
88•	18.76		36.67		70.12		128.93													
90	19.23		37.58		71.87		132.16													
96•	20.65		40.36		77.19		141.93													
100	21.56		42.14		80.58															
108•	23.39		45.71		87.42															
110	23.88		46.67		89.24															
112•	24.31		47.51																	
120	26.23		51.25																	
144	24.91		48.68																	
160	35.59		69.54																	
200	44.87		87.69																	

Ratings are based on strength calculation. Basic static strength rating, or for hand operation of above gears, is approximately 3 times the 100 RPM rating.

• Designates stock sizes for this pitch.

Note: 1. Ratings to right of heavy line are not recommended, as pitch line velocity exceeds 1000 feet per minute. They should be used for interpolation purposes only.

2. Non-metallic gears are most commonly used for the driving pinion of a pair of gears, with mating gear made of Cast Iron or Steel, where pitch line velocities exceed 1000 FPM and are not subjected to shock loads.



# SPUR GEAR HORSEPOWER RATINGS

For  
Class I Service (Service Factor = 1.0)

6 Diametral Pitch

20° Pressure Angle

2" Face

No. Teeth	25 RPM		50 RPM		100 RPM		200 RPM		300 RPM		500 RPM		600 RPM		900 RPM		1200 RPM		1800 RPM	
	S	CI	S	CI	S	CI	S	CI	S	CI	S	CI	S	CI	S	CI	S	CI	S	CI
11•	0.67		1.32		2.54		4.73		6.63		9.79		11.11		14.34		16.78		20.21	
12•	0.79		1.56		3.00		5.59		7.84		11.58		13.14		16.96		19.84		23.91	
13	0.93		1.82		3.50		6.52		9.15		13.51		15.34		19.80		23.16		27.91	
14•	1.04		2.05		3.94		7.35		10.31		15.21		17.27		22.29		26.08		31.42	
15•	1.17		2.30		4.43		8.24		11.56		17.07		19.37		25.01		29.26		35.25	
16•	1.28		2.50		4.82		8.97		12.59		18.58		21.10		27.23		31.85		38.38	
17	1.39		2.72		5.24		9.76		13.69		20.21		22.95		29.61		34.65			
18•	1.50		2.94		5.66		10.54		14.79		21.83		24.78		31.98		37.42			
19	1.61		3.16		6.09		11.34		15.91		23.49		26.66		34.41		40.26			
20	1.73		3.39		6.53		12.17		17.07		25.20		28.60		36.92		43.19			
21•	1.84		3.62		6.97		12.97		18.21		26.87		30.50		39.37		46.06			
22	1.96		3.85		7.41		13.80		19.37		28.59		32.45		41.88		49.00			
24•	2.19		4.29		8.26		15.38		21.57		31.85		36.15		46.65		54.59			
25	2.30		4.51		8.68		16.16		22.67		33.47		37.99		49.03					
26	2.42		4.74		9.13		17.00		23.86		35.22		39.97		51.59					
27•	2.54		4.98		9.59		17.86		25.06		37.00		41.99		54.20					
28	2.66		5.22		10.06		18.74		26.29		38.81		44.05		56.85					
30•	2.90		5.69		10.97		20.42		28.65		42.29		48.00		61.95					
32	3.15		6.17		11.89		22.14		31.07		45.86		52.06							
33•	3.27		6.42		12.36		23.02		32.31		47.69		54.13							
35	3.54		6.94		13.36		24.88		34.92		51.54		58.50							
36•	3.67		7.19		13.86		25.80		36.20		53.44		60.66							
40	4.21		8.25		15.89		29.58		41.51		61.27		69.54							
42•	4.46		8.75		16.85		31.38		44.03		64.99		73.77							
44	4.72		9.26		17.83		33.21		46.59		68.78		78.07							
45	4.85		9.52		18.33		34.13		47.89		70.70		80.25							
48•	5.27		10.33		19.90		37.05		51.98		76.73									
50	5.51		10.81		20.83		38.78		54.42		80.32									
52	5.78		11.33		21.82		40.63		57.01		84.15									
54•	6.04		11.85		22.82		42.50		59.63		88.02									
55	6.15		12.07		23.25		43.29		60.74											
56	6.28		12.32		23.73		44.18		61.99											
60•	6.83		13.39		25.79		48.02		67.38											
64•	7.33		14.39		27.70		51.59		72.38											
66•	7.60		14.91		28.71		53.45		75.00											
70	8.12		15.92		30.66		57.09		80.10											
72•	8.35		16.37		31.54		58.72		82.39											
80	9.43		18.49		35.61		66.31		93.04											
84•	9.97		19.55		37.65		70.10		98.36											
88	10.46		20.53		39.53		73.61		103.28											
90	10.73		21.04		40.52		75.45													
96•	11.52		22.60		43.52		81.03													
100	12.03		23.59		45.43		84.60													
108•	13.05		25.59		49.29		91.77													
110	13.32		26.12		50.31		93.68													
112	13.56		26.60		51.23		95.39													
120•	14.63		28.69		55.25															
144	13.89		27.25		52.49															
160	19.85		38.93		74.98															
200	25.03		49.09		94.54															

Ratings are based on strength calculation. Basic static strength rating, or for hand operation of above gears, is approximately 3 times the 100 RPM rating. • Designates stock sizes for this pitch.

- Note: 1. Ratings to right of heavy line are not recommended, as pitch line velocity exceeds 1000 feet per minute. They should be used for interpolation purposes only.
2. Non-metallic gears are most commonly used for the driving pinion of a pair of gears, with mating gear made of Cast Iron or Steel, where pitch line velocities exceed 1000 FPM and are not subjected to shock loads.



# SPUR GEAR HORSEPOWER RATINGS

For  
Class I Service (Service Factor = 1.0)

8 Diametral Pitch

20° Pressure Angle

1½" Face

No. Teeth	25 RPM		50 RPM		100 RPM		200 RPM		300 RPM		500 RPM		600 RPM		900 RPM		1200 RPM		1800 RPM	
	S	CI	S	CI	S	CI	S	CI	S	CI	S	CI	S	CI	S	CI	S	CI	S	CI
11	0.28		0.56		1.09		2.06		2.94		4.45		5.10		6.76		8.07		10.00	
12•	0.34		0.66		1.29		2.44		3.48		5.26		6.03		7.99		9.54		11.83	
13	0.39		0.78		1.51		2.85		4.06		6.14		7.04		9.33		11.14		13.81	
14•	0.44		0.87		1.70		3.21		4.57		6.91		7.93		10.50		12.54		15.55	
15•	0.50		0.98		1.90		3.60		5.13		7.76		8.90		11.78		14.07		17.45	
16•	0.54		1.07		2.07		3.92		5.58		8.44		9.69		12.83		15.31		18.99	
17	0.59		1.16		2.25		4.26		6.07		9.18		10.53		13.95		16.66		20.66	
18•	0.64		1.25		2.43		4.61		6.56		9.92		11.38		15.07		17.99		22.31	
19•	0.68		1.35		2.62		4.96		7.06		10.67		12.24		16.22		19.36		24.01	
20•	0.73		1.45		2.81		5.32		7.57		11.45		13.13		17.40		20.77		25.76	
21	0.78		1.54		3.00		5.67		8.07		12.21		14.00		18.55		22.14			
22•	0.83		1.64		3.19		6.03		8.59		12.99		14.90		19.73		23.56			
24•	0.93		1.83		3.55		6.72		9.56		14.47		16.60		21.98		26.24			
25	0.97		1.92		3.73		7.06		10.05		15.21		17.44		23.10		27.58			
26•	1.02		2.02		3.93		7.43		10.58		16.00		18.35		24.31		29.02			
27	1.08		2.12		4.12		7.80		11.11		16.81		19.28		25.54		30.49			
28•	1.13		2.23		4.33		8.19		11.66		17.63		20.22		26.79		31.98			
30•	1.23		2.43		4.71		8.92		12.70		19.21		22.04		29.19		34.85			
32•	1.33		2.63		5.11		9.68		13.77		20.84		23.90		31.66					
33	1.39		2.73		5.31		10.06		14.32		21.67		24.85		32.92					
35	1.50		2.96		5.74		10.87		15.48		23.42		26.86		35.58					
36•	1.56		3.06		5.96		11.27		16.05		24.28		27.85		36.89					
40•	1.78		3.51		6.83		12.92		18.40		27.84		31.93		42.29					
42•	1.89		3.73		7.24		13.71		19.52		29.53		33.87		44.86					
44•	2.00		3.94		7.67		14.51		20.66		31.25		35.84		47.48					
45	2.06		4.05		7.88		14.91		21.23		32.12		36.84							
48•	2.23		4.40		8.55		16.19		23.05		34.86		39.99							STEEL
50		1.12		2.21		4.30		8.13		11.58		17.52		20.09						CAST
52•		1.18		2.32		4.50		8.52		12.13		18.35		21.05						
54		1.23		2.42		4.71		8.91		12.69		19.20		22.02						
55		1.25		2.47		4.80		9.08		12.93		19.55		22.43						
56•		1.28		2.52		4.90		9.27		13.19		19.96		22.89						
60•		1.39		2.74		5.32		10.07		14.34		21.69		24.88						
64•		1.49		2.94		5.72		10.82		15.40		23.30								
66		1.55		3.05		5.92		11.21		15.96		24.14								
70		1.65		3.26		6.33		11.97		17.05		25.79								
72•		1.70		3.35		6.51		12.32		17.53										
80•		1.92		3.78		7.35		13.91		19.80										
84		2.03		4.00		7.77		14.70		20.93										
88•		2.13		4.20		8.16		15.44		21.98										
90		2.18		4.30		8.36		15.82		22.53										
96•		2.34		4.62		8.98		16.99		24.20										
100		2.45		4.82		9.37		17.74		25.26										
108		2.66		5.23		10.17		19.25		27.40										
110		2.71		5.34		10.38		19.65		27.97										
112•		2.76		5.44		10.57		20.01		28.48										
120•		2.98		5.87		11.40		21.58		30.72										
144•		2.83		5.57		10.83		20.50												
160•		4.04		7.96		15.47		29.28												
200		5.09		10.04		19.51		36.92												

Ratings are based on strength calculation. Basic static strength rating, or for hand operation of above gears, is approximately 3 times the 100 RPM rating. • Designates stock sizes for this pitch.

Note: 1. Ratings to right of heavy line are not recommended, as pitch line velocity exceeds 1000 feet per minute. They should be used for interpolation purposes only.

2. Non-metallic gears are most commonly used for the driving pinion of a pair of gears, with mating gear made of Cast Iron or Steel, where pitch line velocities exceed 1000 FPM and are not subjected to shock loads.



# SPUR GEAR HORSEPOWER RATINGS

For  
Class I Service (Service Factor = 1.0)

10 Diametral Pitch

20° Pressure Angle

1 1/4" Face

No. Teeth	25 RPM		50 RPM		100 RPM		200 RPM		300 RPM		500 RPM		600 RPM		900 RPM		1200 RPM		1800 RPM	
	S	CI	S	CI	S	CI	S	CI	S	CI	S	CI	S	CI	S	CI	S	CI	S	CI
11	0.15		0.30		0.59		1.13		1.62		2.49		2.87		3.88		4.70		5.95	
12•	0.18		0.36		0.70		1.33		1.91		2.94		3.40		4.58		5.55		7.04	
13	0.21		0.42		0.81		1.55		2.23		3.43		3.97		5.35		6.48		8.22	
14•	0.24		0.47		0.91		1.75		2.51		3.87		4.47		6.02		7.30		9.25	
15•	0.27		0.53		1.03		1.96		2.82		4.34		5.01		6.76		8.19		10.38	
16•	0.29		0.57		1.12		2.14		3.07		4.72		5.45		7.36		8.91		11.30	
17	0.31		0.62		1.22		2.32		3.34		5.14		5.93		8.00		9.70		12.30	
18•	0.34		0.67		1.31		2.51		3.61		5.55		6.41		8.64		10.47		13.28	
19	0.37		0.72		1.41		2.70		3.88		5.97		6.89		9.30		11.27		14.29	
20•	0.39		0.78		1.52		2.90		4.16		6.40		7.40		9.98		12.09		15.33	
21	0.42		0.83		1.62		3.09		4.44		6.83		7.89		10.64		12.89		16.35	
22•	0.44		0.88		1.72		3.29		4.72		7.26		8.39		11.32		13.71		17.39	
24•	0.50		0.98		1.91		3.66		5.26		8.09		9.35		12.61		15.28		19.37	
25•	0.52		1.03		2.01		3.85		5.53		8.50		9.82		13.25		16.05		20.36	
26•	0.55		1.08		2.12		4.05		5.82		8.95		10.34		13.94		16.89			
27	0.58		1.14		2.22		4.25		6.11		9.40		10.86		14.65		17.75			
28•	0.60		1.19		2.33		4.46		6.41		9.86		11.39		15.37		18.61			
30•	0.66		1.30		2.54		4.86		6.99		10.74		12.41		16.74		20.28			
32•	0.71		1.41		2.76		5.27		7.58		11.65		13.46		18.16		22.00			
33	0.74		1.47		2.87		5.48		7.88		12.11		14.00		18.88		22.87			
35•	0.80		1.59		3.10		5.93		8.52		13.09		15.13		20.41		24.72			
36•	0.83		1.64		3.21		6.14		8.83		13.58		15.68		21.16		25.63			
40•	0.95		1.88		3.68		7.04		10.12		15.56		17.98		24.26					
42	1.01		2.00		3.91		7.47		10.74		16.51		19.07		25.73					
44	1.07		2.12		4.14		7.91		11.36		17.47		20.19		27.23					
45•	1.10		2.18		4.25		8.13		11.68		17.96		20.75		27.99					
48•	1.19		2.36		4.61		8.82		12.68		19.49		22.52		30.38					
50•	1.25		2.47		4.83		9.24		13.27		20.41		23.57							
52	1.31		2.59		5.06		9.68		13.90		21.38		24.70							
54	1.37		2.71		5.29		10.12		14.54		22.36		25.83							
55•	1.40		2.76		5.39		10.31		14.81		22.78		26.31							
56	1.42		2.82		5.50		10.52		15.12		23.25		26.86							
60•	1.55		3.06		5.98		11.44		16.43		25.27		29.19							
64		0.80		1.58		3.08		5.90		8.47		13.03		15.05						
66		0.83		1.63		3.19		6.11		8.78		13.50		15.60						
70•		0.88		1.75		3.41		6.53		9.38		14.42		16.66						
72		0.91		1.80		3.51		6.71		9.65		14.83		17.13						
80•		1.03		2.03		3.96		7.58		10.89		16.75								
84		1.08		2.14		4.19		8.01		11.52		17.71								
88		1.14		2.25		4.40		8.41		12.09		18.59								
90•		1.17		2.31		4.51		8.62		12.39		19.06								
96		1.25		2.48		4.84		9.26		13.31										
100•		1.31		2.59		5.06		9.67		13.90										
108		1.42		2.81		5.49		10.49		15.08										
110		1.45		2.87		5.60		10.71		15.39										
112		1.48		2.92		5.70		10.90		15.67										
120		1.59		3.15		6.15		11.76		16.90										
144		1.51		2.99		5.84		11.17		16.05										
160		2.16		4.27		8.35		15.96		22.93										
200		2.72		5.38		10.52		20.12		28.92										

Ratings are based on strength calculation. Basic static strength rating, or for hand operation of above gears, is approximately 3 times the 100 RPM rating.

• Designates stock sizes for this pitch.

Note: 1. Ratings to right of heavy line are not recommended, as pitch line velocity exceeds 1000 feet per minute. They should be used for interpolation purposes only.

2. Non-metallic gears are most commonly used for the driving pinion of a pair of gears, with mating gear made of Cast Iron or Steel, where pitch line velocities exceed 1000 FPM and are not subjected to shock loads.



# SPUR GEAR HORSEPOWER RATINGS

For  
Class I Service (Service Factor = 1.0)

12 Diametral Pitch

20° Pressure Angle

1" Face

No. Teeth	25 RPM		50 RPM		100 RPM		200 RPM		300 RPM		500 RPM		600 RPM		900 RPM		1200 RPM		1800 RPM	
	S	CI	S	CI	S	CI	S	CI	S	CI	S	CI	S	CI	S	CI	S	CI	S	CI
11	0.08		0.17		0.33		0.63		0.92		1.43		1.66		2.27		2.78		3.58	
12•	0.10		0.20		0.39		0.75		1.09		1.69		1.96		2.68		3.28		4.24	
13•	0.12		0.23		0.45		0.88		1.27		1.97		2.29		3.13		3.83		4.95	
14•	0.13		0.26		0.51		0.99		1.43		2.22		2.58		3.52		4.32		5.57	
15•	0.15		0.29		0.57		1.11		1.60		2.49		2.89		3.95		4.84		6.25	
16•	0.16		0.32		0.63		1.20		1.74		2.71		3.15		4.30		5.27		6.81	
17	0.18		0.35		0.68		1.31		1.90		2.95		3.42		4.68		5.74		7.40	
18•	0.19		0.37		0.73		1.42		2.05		3.18		3.70		5.06		6.19		7.99	
19•	0.20		0.40		0.79		1.52		2.20		3.43		3.98		5.44		6.67		8.60	
20•	0.22		0.43		0.85		1.63		2.36		3.68		4.27		5.84		7.15		9.23	
21•	0.23		0.46		0.90		1.74		2.52		3.92		4.55		6.22		7.63		9.84	
22•	0.25		0.49		0.96		1.85		2.68		4.17		4.84		6.62		8.11		10.47	
24•	0.28		0.55		1.07		2.06		2.99		4.64		5.39		7.38		9.04		11.66	
25•	0.29		0.57		1.13		2.17		3.14		4.88		5.67		7.75		9.50		12.26	
26•	0.31		0.60		1.19		2.28		3.30		5.14		5.96		8.16		9.99		12.90	
27	0.32		0.63		1.25		2.40		3.47		5.40		6.27		8.57		10.50		13.55	
28•	0.34		0.67		1.31		2.52		3.64		5.66		6.57		8.99		11.01		14.21	
30•	0.37		0.73		1.42		2.74		3.96		6.17		7.16		9.79		12.00		15.49	
32•	0.40		0.79		1.54		2.97		4.30		6.69		7.77		10.62		13.01			
33	0.41		0.82		1.61		3.09		4.47		6.95		8.08		11.05		13.53			
35	0.45		0.88		1.73		3.34		4.83		7.52		8.73		11.94		14.63			
36•	0.46		0.92		1.80		3.46		5.01		7.79		9.05		12.38		15.16			
40	0.53		1.05		2.06		3.97		5.74		8.94		10.38		14.19		17.39			
42•	0.56		1.12		2.19		4.21		6.09		9.48		11.01		15.05		18.44			
44	0.60		1.18		2.32		4.46		6.45		10.03		11.65		15.93		19.52			
45	0.61		1.21		2.38		4.58		6.63		10.31		11.97		16.37		20.06			
48•	0.66		1.32		2.58		4.97		7.19		11.19		13.00		17.77					
50	0.70		1.38		2.70		5.21		7.53		11.71		13.60		18.60					
52	0.73		1.44		2.83		5.45		7.89		12.27		14.25		19.49					
54•	0.76		1.51		2.96		5.71		8.25		12.84		14.91		20.39					
55	0.78		1.54		3.02		5.81		8.41		13.08		15.18		20.77					
56	0.79		1.57		3.08		5.93		8.58		13.35		15.50		21.19					
60•	0.86		1.71		3.35		6.45		9.33		14.51		16.84		23.04					
64	0.93		1.83		3.60		6.93		10.02		15.58		18.10		24.75					
66•	0.96		1.90		3.73		7.18		10.38		16.15		18.75							
70	1.02		2.03		3.98		7.66		11.09		17.24		20.03							
72•	1.05		2.09		4.09		7.88		11.40											
80		0.57		1.13		2.22		4.27		6.18		9.61		11.16						
84•		0.60		1.20		2.35		4.52		6.53		10.16		11.80						
88		0.63		1.26		2.46		4.74		6.86		10.67		12.39						
90		0.65		1.29		2.52		4.86		7.03		10.94								
96•		0.70		1.38		2.71		5.22		7.55		11.75								
100		0.73		1.44		2.83		5.45		7.89		12.27								
108•		0.79		1.57		3.07		5.91		8.55		13.31								
110		0.81		1.60		3.13		6.04		8.73		13.58								
112		0.82		1.63		3.19		6.15		8.89										
120•		0.89		1.76		3.44		6.63		9.59										
144•		0.84		1.67		3.27		6.30		9.11										
160		1.20		2.38		4.67		9.00		13.01										
200		1.52		3.00		5.89		11.34		16.41										

Ratings are based on strength calculation. Basic static strength rating, or for hand operation of above gears, is approximately 3 times the 100 RPM rating.

• Designates stock sizes for this pitch.

Note: 1. Ratings to right of heavy line are not recommended, as pitch line velocity exceeds 1000 feet per minute. They should be used for interpolation purposes only.

2. Non-metallic gears are most commonly used for the driving pinion of a pair of gears, with mating gear made of Cast Iron or Steel, where pitch line velocities exceed 1000 FPM and are not subjected to shock loads.

# SPUR GEAR HORSEPOWER RATINGS



For  
Class I Service (Service Factor = 1.0)

16 Diametral Pitch

20° Pressure Angle

3/4" Face

No. Teeth	25 RPM		50 RPM		100 RPM		200 RPM		300 RPM		500 RPM		600 RPM		900 RPM		1200 RPM		1800 RPM	
	S	CI	S	CI	S	CI	S	CI	S	CI	S	CI	S	CI	S	CI	S	CI	S	CI
11	0.04		0.07		0.14		0.27		0.40		0.63		0.73		1.02		1.28		1.69	
12*	0.04		0.08		0.17		0.32		0.47		0.74		0.87		1.21		1.51		2.00	
13*	0.05		0.10		0.19		0.38		0.55		0.87		1.01		1.41		1.76		2.33	
14*	0.06		0.11		0.22		0.42		0.62		0.98		1.14		1.59		1.98		2.63	
15*	0.06		0.12		0.24		0.48		0.69		1.10		1.28		1.79		2.22		2.95	
16*	0.07		0.14		0.27		0.52		0.76		1.19		1.40		1.94		2.42		3.21	
17*	0.07		0.15		0.29		0.56		0.82		1.30		1.52		2.12		2.63		3.49	
18*	0.08		0.16		0.31		0.61		0.89		1.40		1.64		2.28		2.84		3.77	
19	0.09		0.17		0.34		0.65		0.95		1.51		1.76		2.46		3.06		4.05	
20*	0.09		0.18		0.36		0.70		1.02		1.62		1.89		2.64		3.28		4.35	
21*	0.10		0.20		0.39		0.75		1.09		1.73		2.02		2.81		3.50		4.64	
22*	0.10		0.21		0.41		0.80		1.16		1.84		2.15		2.99		3.72		4.93	
24*	0.12		0.23		0.46		0.89		1.29		2.04		2.39		3.33		4.15		5.50	
25	0.12		0.24		0.48		0.93		1.36		2.15		2.51		3.50		4.36		5.78	
26*	0.13		0.26		0.50		0.98		1.43		2.26		2.64		3.69		4.59		6.08	
27	0.14		0.27		0.53		1.03		1.50		2.38		2.78		3.87		4.82		6.38	
28*	0.14		0.28		0.56		1.08		1.58		2.49		2.91		4.06		5.06		6.70	
30*	0.15		0.31		0.61		1.18		1.72		2.72		3.18		4.43		5.51		7.30	
32*	0.17		0.33		0.66		1.28		1.86		2.94		3.44		4.80		5.98		7.91	
33	0.17		0.35		0.68		1.33		1.94		3.06		3.58		4.99		6.21		8.23	
35	0.19		0.37		0.74		1.44		2.09		3.31		3.87		5.39		6.72		8.89	
36*	0.20		0.39		0.77		1.49		2.17		3.43		4.01		5.59		6.96		9.22	
40*	0.22		0.45		0.88		1.71		2.49		3.93		4.60		6.41		7.98		10.57	
42	0.24		0.47		0.93		1.81		2.64		4.17		4.88		6.80		8.47			
44	0.25		0.50		0.99		1.92		2.80		4.42		5.16		7.20		8.96			
45	0.26		0.51		1.01		1.97		2.87		4.54		5.31		7.40		9.21			
48*	0.28		0.56		1.10		2.14		3.12		4.93		5.76		8.03		10.00			
50	0.29		0.58		1.15		2.24		3.26		5.16		6.03		8.41		10.47			
52	0.31		0.61		1.21		2.34		3.42		5.40		6.32		8.81		10.96			
54	0.32		0.64		1.26		2.45		3.58		5.65		6.61		9.21		11.47			
55	0.33		0.65		1.29		2.50		3.64		5.76		6.73		9.38		11.68			
56*	0.34		0.67		1.31		2.55		3.72		5.88		6.87		9.58					
60*	0.36		0.72		1.43		2.77		4.04		6.39		7.47		10.41					
64*	0.39		0.78		1.53		2.98		4.34		6.86		8.02		11.18					
66	0.41		0.81		1.59		3.08		4.50		7.11		8.31		11.58					
70	0.43		0.86		1.70		3.29		4.81		7.59		8.88		12.37					
72*	0.45		0.88		1.74		3.39		4.94		7.81		9.13		12.73					
80*	0.50		1.00		1.97		3.83		5.58		8.82		10.31		14.37					
84*	0.53		1.06		2.08		4.05		5.90		9.32		10.90		15.19					
88*	0.56		1.11		2.19		4.25		6.20		9.79		11.45							
90	0.57		1.14		2.24		4.35		6.35		10.03		11.73							
96*	0.62		1.22		2.41		4.68		6.82		10.78		12.60							
100	0.64		1.27		2.51		4.88		7.12		11.25		13.16							
108		0.33		0.66		1.31		2.54		3.71		5.86		6.85						
110		0.34		0.68		1.34		2.60		3.79		5.98		6.99						
112*		0.35		0.69		1.36		2.64		3.85		6.09		7.12						
120		0.37		0.74		1.47		2.85		4.16		6.57		7.68						
144*		0.36		0.71		1.39		2.71		3.95		6.24								
160*		0.51		1.01		1.99		3.87		5.64		8.91								
200		0.64		1.27		2.51		4.88		7.11		11.24								

Ratings are based on strength calculation. Basic static strength rating, or for hand operation of above gears, is approximately 3 times the 100 RPM rating.

• Designates stock sizes for this pitch.

Note: 1. Ratings to right of heavy line are not recommended, as pitch line velocity exceeds 1000 feet per minute. They should be used for interpolation purposes only.

2. Non-metallic gears are most commonly used for the driving pinion of a pair of gears, with mating gear made of Cast Iron or Steel, where pitch line velocities exceed 1000 FPM and are not subjected to shock loads.



# SPUR GEAR HORSEPOWER RATINGS

For  
Class I Service (Service Factor = 1.0)

20 Diametral Pitch

20° Pressure Angle

1/2" Face

No. Teeth	25 RPM		50 RPM		100 RPM		200 RPM		300 RPM		500 RPM		600 RPM		900 RPM		1200 RPM		1800 RPM	
	S	CI	S	CI	S	CI	S	CI	S	CI	S	CI	S	CI	S	CI	S	CI	S	CI
11	0.02		0.03		0.06		0.12		0.17		0.28		0.32		0.46		0.57		0.78	
12•	0.02		0.04		0.07		0.14		0.20		0.33		0.38		0.54		0.68		0.92	
13	0.02		0.04		0.08		0.16		0.24		0.38		0.45		0.63		0.79		1.07	
14•	0.02		0.05		0.09		0.18		0.27		0.43		0.50		0.71		0.89		1.20	
15•	0.03		0.05		0.11		0.21		0.30		0.48		0.56		0.80		1.00		1.35	
16•	0.03		0.06		0.11		0.22		0.33		0.52		0.61		0.87		1.09		1.47	
17	0.03		0.06		0.12		0.24		0.36		0.57		0.67		0.94		1.19		1.60	
18•	0.03		0.07		0.13		0.26		0.38		0.61		0.72		1.02		1.28		1.73	
19	0.04		0.07		0.14		0.28		0.41		0.66		0.78		1.10		1.38		1.86	
20•	0.04		0.08		0.16		0.30		0.44		0.71		0.83		1.18		1.48		2.00	
21•	0.04		0.08		0.17		0.32		0.47		0.76		0.89		1.25		1.58		2.13	
22•	0.04		0.09		0.18		0.34		0.50		0.80		0.94		1.33		1.68		2.26	
24•	0.05		0.10		0.20		0.38		0.56		0.90		1.05		1.49		1.87		2.52	
25•	0.05		0.10		0.21		0.40		0.59		0.94		1.11		1.56		1.96		2.65	
26	0.06		0.11		0.22		0.42		0.62		0.99		1.16		1.64		2.07		2.79	
27	0.06		0.12		0.23		0.44		0.65		1.04		1.22		1.73		2.17		2.93	
28•	0.06		0.12		0.24		0.47		0.68		1.09		1.28		1.81		2.28		3.07	
30•	0.07		0.13		0.26		0.51		0.75		1.19		1.40		1.97		2.48		3.35	
32•	0.07		0.14		0.28		0.55		0.81		1.29		1.52		2.14		2.69		3.63	
33	0.07		0.15		0.29		0.57		0.84		1.34		1.58		2.22		2.80		3.78	
35•	0.08		0.16		0.32		0.62		0.91		1.45		1.70		2.40		3.03		4.08	
36•	0.08		0.17		0.33		0.64		0.94		1.50		1.77		2.49		3.14		4.23	
40•	0.10		0.19		0.38		0.74		1.08		1.72		2.02		2.86		3.60		4.85	
42	0.10		0.20		0.40		0.78		1.15		1.83		2.15		3.03		3.81		5.15	
44	0.11		0.21		0.42		0.83		1.21		1.93		2.27		3.21		4.04		5.45	
45•	0.11		0.22		0.44		0.85		1.25		1.99		2.34		3.30		4.15		5.60	
48	0.12		0.24		0.47		0.92		1.35		2.16		2.54		3.58		4.50		6.08	
50•	0.13		0.25		0.49		0.97		1.42		2.26		2.65		3.75		4.71		6.36	
52	0.13		0.26		0.52		1.01		1.48		2.37		2.78		3.92		4.94		6.66	
54	0.14		0.27		0.54		1.06		1.55		2.48		2.91		4.10		5.17			
55	0.14		0.28		0.55		1.08		1.58		2.52		2.96		4.18		5.26			
56	0.14		0.28		0.56		1.10		1.61		2.57		3.02		4.27		5.37			
60•	0.16		0.31		0.61		1.20		1.75		2.80		3.29		4.64		5.84			
64	0.17		0.33		0.66		1.28		1.88		3.01		3.53		4.98		6.27			
66	0.17		0.34		0.68		1.33		1.95		3.11		3.66		5.16		6.50			
70•	0.19		0.37		0.73		1.42		2.08		3.33		3.91		5.51		6.94			
72•	0.19		0.38		0.75		1.46		2.14		3.42		4.02		5.67		7.14			
80•	0.22		0.43		0.85		1.65		2.42		3.86		4.54		6.40					
84•	0.23		0.45		0.89		1.75		2.56		4.08		4.80		6.77					
88	0.24		0.47		0.94		1.83		2.69		4.29		5.04		7.11					
90•	0.24		0.49		0.96		1.88		2.76		4.40		5.16		7.29					
96•	0.26		0.52		1.03		2.02		2.96		4.72		5.55		7.83					
100•	0.27		0.55		1.08		2.11		3.09		4.93		5.79		8.17					
108	0.30		0.59		1.17		2.29		3.35		5.35		6.28							
110	0.30		0.60		1.19		2.33		3.42		5.46		6.41							
112	0.31		0.62		1.22		2.38		3.48		5.56		6.53							
120•	0.33		0.66		1.31		2.56		3.76		5.99		7.04							
144	0.32		0.63		1.25		2.43		3.57		5.69		6.69							
160	0.45		0.90		1.78		3.48		5.10		8.13		9.56							
200	0.57		1.14		2.24		4.38		6.43		10.26		12.05							

Ratings are based on strength calculation. Basic static strength rating, or for hand operation of above gears, is approximately 3 times the 100 RPM rating.

• Designates stock sizes for this pitch.

Note: 1. Ratings to right of heavy line are not recommended, as pitch line velocity exceeds 1000 feet per minute. They should be used for interpolation purposes only.

2. Non-metallic gears are most commonly used for the driving pinion of a pair of gears, with mating gear made of Cast Iron or Steel, where pitch line velocities exceed 1000 FPM and are not subjected to shock loads.

# WORMS & WORM GEARS

## WORMS & WORM GEARS

Worms and worm gears are used to power right angle, nonintersecting shafts. In normal applications the worm gear is driven by the worm.

The most popular use of worms and worm gears is in applications where high ratio speed reduction is desired in a relatively limited space. They are also used in applications where high resistance to the worm gear shaft reversing and driving back through the worm is desired.

*Right Hand Worm and Gear*



*Single, Double, quadruple thread worms.*



The worms (shown above) are cylindrical in form with their face usually greater than their diameter. They have one or more threads, or starts; giving them an appearance not unlike a screw.

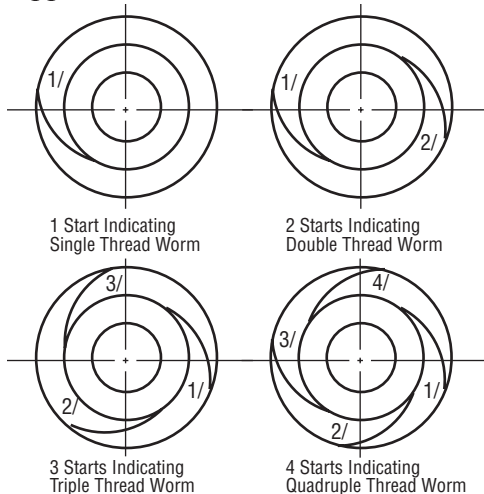

A stock worm may have one, two, three or four threads. The number of threads can be identified by counting the number of starts at the end.

Worms and worm gears are also available with right hand or left hand threads.

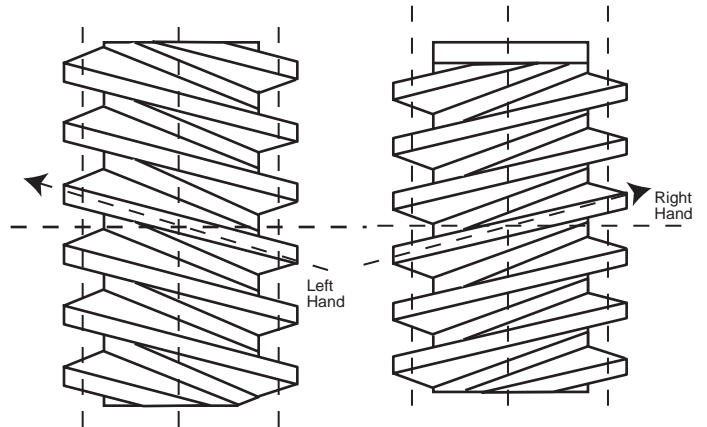

*Left Hand Worm*

*Right Hand Worm*

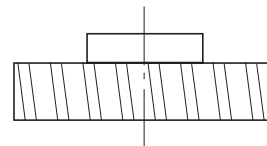

*Left Hand Worm Gear*

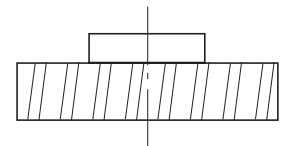

*Right Hand Worm Gear*

*Martin* stock worms and worm gears can be furnished as follows:

### WORMS

- Soft or hardened steel
- With or without hubs
- Right hand or left hand
- Single - Double - Triple or Quadruple Thread

### WORM GEARS

- Bronze or Cast Iron
- Right or left hand
- Single - Double - Triple or Quadruple Thread

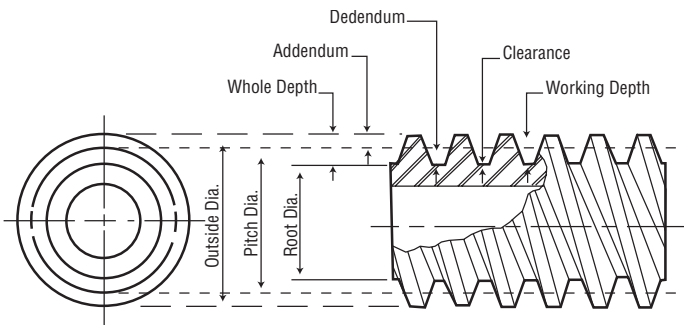

Some Rules for Calculating Worm Sizes and Proportions

$$\text{Whole Depth} = \frac{2.157}{\text{Dia. Pitch}}$$

$$\text{Addendum} = \frac{1}{\text{Dia. Pitch}}$$

$$\text{Dedendum} = \text{Whole Depth} - \text{Addendum}$$

$$\text{Working Depth} = 2 \times \text{Addendum}$$

$$\text{Clearance} = \text{Whole Depth} - 2 \times \text{Addendum}$$

Pitch Diameter is the result of the diameter of hob used in manufacture. The diameter of the worm can be made various sizes depending on desired results. When the diameter changes the helix angle also changes; therefore, the worm diameter determines the general design of the set and tooling used. Worm diameters shown in the catalog have been selected as standard for stock gears.

$$\text{Outside Diameter} = \text{Pitch Diameter} + 2 \times \text{Addendum}$$

$$\text{Bottom Diameter} = \text{Outside Diameter} - 2 \times \text{Whole Depth}$$

The lead of a worm is the distance a thread advances axially when the worm turns one complete revolution.

The circular or linear pitch of a worm is the measurement from a point on one thread to the corresponding point of an adjacent thread.

The following sketches show the pitch remains the same while the lead increases in proportion to the increase in threads.

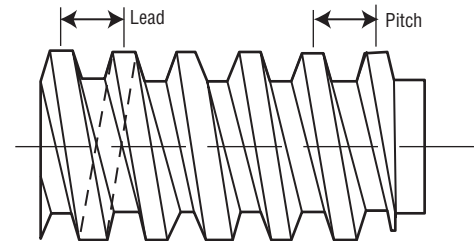

SINGLE THREAD WORM

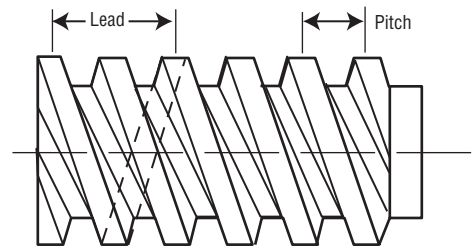

DOUBLE THREAD WORM

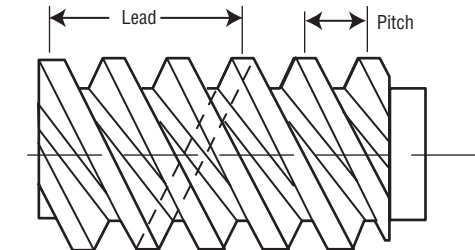

TRIPLE THREAD WORM

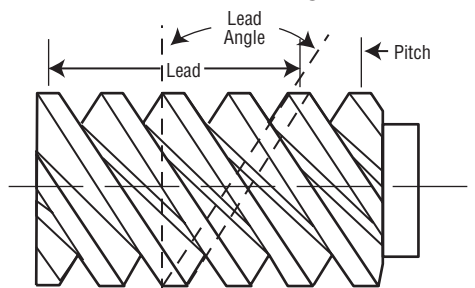

QUADRUPLE THREAD WORM

Single Thread Worm —

$$\text{Cir. Pitch} = \text{Lead}$$

Double Thread Worm —

$$\text{Cir. Pitch} = \frac{\text{Lead}}{2} \text{ or } \text{Lead} = \text{Cir. Pitch} \times 2$$

Triple Thread Worm —

$$\text{Cir. Pitch} = \frac{\text{Lead}}{3} \text{ or } \text{Lead} = \text{Cir. Pitch} \times 3$$

Quadruple Thread Worm —

$$\text{Cir. Pitch} = \frac{\text{Lead}}{4} \text{ or } \text{Lead} = \text{Cir. Pitch} \times 4$$



# WORMS & WORM GEARS

The preceding illustrations indicates the Lead (helix) angle of the worm is the result of a line drawn perpendicular to the worm axis and a line parallel to the worm thread.

If the helix angle is to be calculated, the Lead and pitch diameter must be known and a table of cotangents available (such as in Machinery Handbook). The following formula may then be used.

$$\frac{PD \times \pi}{LEAD} = \text{Cot of Lead Angle}$$

## Trigonometric Functions

°	'	Sine	Tan.	Cotan.	Cosine	°	'	°	'	Sine	Tan.	Cotan.	Cosine	°	'
0	0	.000000	.000000	INFINITE	1.000000	0	90	11	0	.190809	.194380	5.1445540	.981627	0	79
	10	.002909	.002909	343.77371	.999996	50			10	.913664	.197401	5.0658352	.981068	50	
	20	.005818	.005818	171.88540	.999983	40			20	.196517	.200425	4.9894027	.980500	40	
	30	.008727	.008727	114.58865	.999962	30			30	.199368	.203452	4.9151570	.979925	30	
	40	.011635	.011635	85.939791	.999932	20			40	.202218	.206483	4.8430045	.979341	20	
	50	.014544	.014544	68.750087	.999894	10			50	.205065	.209518	4.7728568	.978748	10	
1	0	.017452	.017455	57.289962	.999848	0	89	12	0	.207912	.212557	4.7046301	.978148	0	78
	10	.020361	.020365	49.103881	.999793	50			10	.210756	.215599	4.6382457	.977539	50	
	20	.023269	.023275	42.964077	.999729	40			20	.213599	.218645	4.5736287	.976921	40	
	30	.026177	.026186	38.188459	.999657	30			30	.216440	.221695	4.5107085	.976296	30	
	40	.029085	.029097	34.367771	.999577	20			40	.219279	.224748	4.4494181	.975662	20	
	50	.031992	.032009	31.241577	.999488	10			50	.222116	.227806	4.3896940	.975020	10	
2	0	.034899	.034921	28.636253	.999391	0	88	13	0	.224951	.230868	4.3314759	.974370	0	77
	10	.037806	.037834	26.431600	.999285	50			10	.227784	.233934	4.2747066	.973712	50	
	20	.040713	.040747	24.541758	.999171	40			20	.230616	.237004	4.2193318	.973045	40	
	30	.043619	.043661	22.903766	.999048	30			30	.233445	.240079	4.1652998	.972370	30	
	40	.046525	.046576	21.470401	.998917	20			40	.236273	.243158	4.1125614	.971687	20	
	50	.049431	.049491	20.205553	.998778	10			50	.239098	.246241	4.0610700	.970995	10	
3	0	.052336	.052408	19.081137	.998630	0	87	14	0	.241922	.249328	4.0107809	.970296	0	76
	10	.055241	.055325	18.074977	.998473	50			10	.244743	.252420	3.9616518	.969588	50	
	20	.058145	.058243	17.169337	.998308	40			20	.247563	.255517	3.9136420	.968872	40	
	30	.061049	.061163	16.349855	.998135	30			30	.250380	.258618	3.8667131	.968148	30	
	40	.063952	.064083	15.604784	.997957	20			40	.253195	.261723	3.8208281	.967415	20	
	50	.066854	.067004	14.924417	.997763	10			50	.256008	.264834	3.7759519	.966675	10	
4	0	.069756	.069927	14.300666	.997564	0	86	15	0	.258819	.267949	3.7320508	.965926	0	75
	10	.072658	.072851	13.726738	.997357	50			10	.261628	.271069	3.6890927	.965169	50	
	20	.075559	.075776	13.196888	.997141	40			20	.264434	.274195	3.6470467	.964404	40	
	30	.078459	.078702	12.706205	.996917	30			30	.267238	.277325	3.6058835	.963630	30	
	40	.081359	.081629	12.250505	.996685	20			40	.270040	.280460	3.5655749	.962849	20	
	50	.084258	.084558	11.826167	.996444	10			50	.272840	.283600	3.5260938	.962059	10	
5	0	.087156	.087489	11.430052	.996195	0	85	16	0	.275637	.286745	3.4874144	.961262	0	74
	10	.090053	.090421	11.059431	.995937	50			10	.278432	.289896	3.4495120	.960456	50	
	20	.092950	.093354	10.711913	.995671	40			20	.281225	.293052	3.4123626	.959642	40	
	30	.095846	.096289	10.385397	.995396	30			30	.284015	.296214	3.3759434	.958820	30	
	40	.098741	.099226	10.078031	.995113	20			40	.286803	.299380	3.3402326	.957990	20	
	50	.101635	.102164	9.7881732	.994822	10			50	.289589	.302553	3.3052091	.957151	10	
6	0	.104528	.105104	9.5143645	.994522	0	84	17	0	.292372	.305731	3.2708526	.956305	0	73
	10	.107421	.108046	9.2553035	.994214	50			10	.295152	.308914	3.2371438	.955450	50	
	20	.110313	.110990	9.0098261	.993897	40			20	.297930	.312104	3.2040638	.954588	40	
	30	.113203	.113936	8.7768874	.993572	30			30	.300706	.315299	3.1715948	.953717	30	
	40	.116093	.116883	8.5554668	.993238	20			40	.303479	.318500	3.1397194	.952838	20	
	50	.118982	.119833	8.3449558	.992896	10			50	.306249	.321707	3.1084210	.951951	10	
7	0	.121869	.122785	8.1443464	.992546	0	83	18	0	.309017	.324920	3.0776835	.951057	0	72
	10	.124756	.125738	7.9530224	.992187	50			10	.311782	.328139	3.0474915	.950154	50	
	20	.127642	.128694	7.7703506	.991820	40			20	.314545	.331364	3.0178301	.949243	40	
	30	.130526	.131653	7.5957541	.991445	30			30	.317305	.334595	2.9886850	.948324	30	
	40	.133410	.134613	7.4287064	.991061	20			40	.320062	.337833	2.9600422	.947397	20	
	50	.136292	.137576	7.2687255	.990669	10			50	.322816	.341077	2.9318885	.946462	10	
8	0	.139173	.140541	7.1153697	.990268	0	82	19	0	.325568	.344328	2.9042109	.945519	0	71
	10	.142053	.143508	6.9682335	.989859	50			10	.328317	.347585	2.8769970	.944568	50	
	20	.144932	.146478	6.8269437	.989442	40			20	.331063	.350848	2.8502349	.943609	40	
	30	.147809	.149451	6.6911562	.989016	30			30	.333807	.354119	2.8239129	.942641	30	
	40	.150686	.152426	6.5605538	.988582	20			40	.336547	.357396	2.7980198	.941666	20	
	50	.153561	.155404	6.4348428	.988139	10			50	.339285	.360680	2.7725448	.940684	10	
9	0	.156434	.158384	6.3137515	.987688	0	81	20	0	.342020	.363970	2.7474774	.939693	0	70
	10	.159307	.161368	6.1970279	.987229	50			10	.344752	.367268	2.7228076	.938694	50	
	20	.162178	.164354	6.0844381	.986762	40			20	.347481	.370573	2.6985254	.937687	40	
	30	.165048	.167343	5.9757644	.986286	30			30	.350207	.373885	2.6746215	.936672	30	
	40	.167916	.170334	5.8708042	.985801	20			40	.352931	.377204	2.6510867	.935650	20	
	50	.170783	.173329	5.7693688	.985309	10			50	.355651	.380530	2.6279121	.934619	10	
10	0	.173648	.176327	5.6712818	.984808	0	80	21	0	.358368	.383864	2.6050891	.933580	0	69
	10	.176512	.179328	5.5763786	.984298	50			10	.361082	.387205	2.5826094	.932534	50	
	20	.179375	.182332	5.4845052	.983781	40			20	.363793	.390554	2.5604649	.931480	40	
	30	.182236	.185339	5.3955172	.983255	30			30	.366501	.393911	2.5386479	.930418	30	
	40	.185095	.188359	5.3092793	.982721	20			40	.369206	.397275	2.5171507	.929348	20	
	50	.187953	.191363	5.2256647	.982178	10			50	.371908	.400647	2.4959661	.928270	10	68
°	'	Cosine	Cotan.	Tan.	Sine	°	'	°	'	Cosine	Cotan.	Tan.	Sine	°	'

NOTE: For functions from 90° to 68°-10' read from bottom of table upward.

### Trigonometric Functions

°	'	Sine	Tan.	Cotan.	Cosine	°	'	°	'	Sine	Tan.	Cotan.	Cosine	°	'
22	0	.374607	.404026	2.4750869	.927184	0	68	34	0	.559193	.674509	1.4825610	.829038	0	56
	10	.377302	.407414	2.4545061	.926090	50			10	.561602	.678749	1.4732983	.827407	50	
	20	.379994	.410810	2.4342172	.924980	40			20	.564007	.683007	1.4641147	.825770	40	
	30	.382683	.414214	2.4142136	.923880	30			30	.566406	.687281	1.4550090	.824126	30	
	40	.385369	.417626	2.3944889	.922762	20			40	.568801	.691573	1.4459801	.822475	20	
	50	.388052	.421046	2.3750372	.921638	10			50	.571191	.695881	1.4370268	.820817	10	
23	0	.390731	.424475	2.3558524	.920505	0	67	35	0	.573576	.700208	1.4281480	.819152	0	55
	10	.393407	.427912	2.3369287	.919364	50			10	.575957	.704552	1.4193427	.817480	50	
	20	.396080	.431358	2.3182606	.918216	40			20	.578332	.708913	1.4106098	.815801	40	
	30	.398749	.434812	2.2998425	.917060	30			30	.580703	.713293	1.4019483	.814116	30	
	40	.401415	.438276	2.2816693	.915896	20			40	.583069	.717691	1.3933571	.812423	20	
	50	.404078	.441748	2.2637357	.914725	10			50	.585429	.722108	1.3848355	.810723	10	
24	0	.406737	.445229	2.2460368	.913545	0	66	36	0	.587785	.726543	1.3763810	.809017	0	54
	10	.409392	.448719	2.2285676	.912358	50			10	.590136	.730996	1.3679959	.807304	50	
	20	.412045	.452218	2.2113234	.911164	40			20	.592482	.735469	1.3596764	.805584	40	
	30	.414693	.455726	2.1942997	.909961	30			30	.594823	.739961	1.3514224	.803857	30	
	40	.417338	.459244	2.1774920	.908751	20			40	.597159	.744472	1.3432331	.802123	20	
	50	.419980	.462771	2.1608958	.907533	10			50	.599489	.749003	1.3351075	.800383	10	
25	0	.422618	.466308	2.1445069	.906308	0	65	37	0	.601815	.753554	1.3270448	.798636	0	53
	10	.425253	.469854	2.1283213	.905075	50			10	.604136	.758125	1.3190441	.796882	50	
	20	.427884	.473410	2.1123348	.903834	40			20	.606451	.762716	1.3111046	.795121	40	
	30	.430511	.476976	2.0965436	.902585	30			30	.608761	.767327	1.3032254	.793353	30	
	40	.433125	.480551	2.0809438	.901329	20			40	.611067	.771959	1.2954057	.791579	20	
	50	.435755	.484137	2.0655318	.900065	10			50	.613367	.776612	1.2876447	.789798	10	
26	0	.438371	.487733	2.0503038	.898794	0	64	38	0	.615661	.781286	1.2799416	.788011	0	52
	10	.440984	.491339	2.0352565	.897515	50			10	.617951	.785981	1.2722957	.786217	50	
	20	.443593	.494955	2.0203862	.896229	40			20	.620235	.790698	1.2647062	.784416	40	
	30	.446197	.498582	2.0056897	.894934	30			30	.622515	.795436	1.2571723	.782608	30	
	40	.448799	.502219	1.9911637	.893633	20			40	.624789	.800196	1.2496933	.780794	20	
	50	.451397	.505867	1.9768050	.892323	10			50	.627057	.804980	1.2422685	.778973	10	
27	0	.453990	.509525	1.9626105	.891007	0	63	39	0	.629320	.809784	1.2348972	.777146	0	51
	10	.456580	.513195	1.9485772	.889682	50			10	.631578	.814612	1.2275786	.775312	50	
	20	.459166	.516876	1.9347020	.888350	40			20	.633831	.819463	1.2203121	.773472	40	
	30	.461749	.520567	1.9209821	.887011	30			30	.636078	.824336	1.2130970	.771625	30	
	40	.464327	.524270	1.9074147	.885664	20			40	.638320	.829234	1.2059327	.769771	20	
	50	.466901	.527984	1.8939971	.884309	10			50	.640557	.834155	1.1988184	.767911	10	
28	0	.469472	.531709	1.8807265	.882948	0	62	40	0	.642788	.839100	1.1917536	.766044	0	50
	10	.472038	.535547	1.8676003	.881578	50			10	.645013	.844069	1.1847376	.764171	50	
	20	.474600	.539195	1.8546159	.880201	40			20	.647233	.849062	1.1777698	.762292	40	
	30	.477149	.542956	1.8417709	.878817	30			30	.649448	.854081	1.1708496	.760406	30	
	40	.479713	.546728	1.8290628	.877425	20			40	.651657	.859124	1.1639763	.758514	20	
	50	.482263	.550515	1.8164892	.876026	10			50	.653861	.864193	1.1571495	.756615	10	
29	0	.484810	.554309	1.8040478	.874620	0	61	41	0	.656059	.869287	1.1503684	.754710	0	49
	10	.487352	.558118	1.7917362	.873206	50			10	.658252	.874407	1.1436326	.752798	50	
	20	.489890	.561939	1.7795524	.871784	40			20	.660439	.879553	1.1369414	.750880	40	
	30	.492424	.565773	1.7674940	.870356	30			30	.662620	.884725	1.1302944	.748956	30	
	40	.494953	.569619	1.7555590	.868920	20			40	.664796	.889924	1.1236909	.747025	20	
	50	.497479	.573478	1.7437453	.867476	10			50	.666966	.895151	1.1171305	.745088	10	
30	0	.500000	.577350	1.7320508	.866025	0	60	42	0	.669131	.900404	1.1106125	.743145	0	48
	10	.502517	.581235	1.7204736	.864567	50			10	.671289	.905685	1.1041365	.741195	50	
	20	.505030	.585134	1.7090116	.863102	40			20	.673443	.910994	1.0977020	.739239	40	
	30	.507538	.589045	1.6976631	.861629	30			30	.675590	.916331	1.0913085	.737277	30	
	40	.510043	.592970	1.6864261	.860149	20			40	.677732	.921697	1.0849554	.735309	20	
	50	.512543	.596908	1.6752988	.858662	10			50	.679868	.927021	1.0786423	.733335	10	
31	0	.515038	.600861	1.6642795	.857167	0	59	43	0	.681998	.932515	1.0723687	.731354	0	47
	10	.517529	.604827	1.6533663	.855665	50			10	.684123	.937968	1.0661341	.729367	50	
	20	.520016	.608807	1.6425576	.854156	40			20	.686242	.943451	1.0599381	.727374	40	
	30	.522499	.612801	1.6318517	.852640	30			30	.688355	.948965	1.0537801	.725374	30	
	40	.524977	.616809	1.6212469	.851117	20			40	.690462	.954508	1.0476598	.723369	20	
	50	.527450	.620832	1.6107417	.849586	10			50	.692563	.960083	1.0415767	.721357	10	
32	0	.529919	.624869	1.6003345	.848048	0	58	44	0	.694658	.965689	1.0355303	.719340	0	46
	10	.532384	.628921	1.5900238	.846503	50			10	.696748	.971326	1.0295203	.717316	50	
	20	.534844	.632988	1.5798079	.844951	40			20	.698832	.976996	1.0235461	.715286	40	
	30	.537300	.637079	1.5696856	.843391	30			30	.700909	.982697	1.0176074	.713251	30	
	40	.539751	.641167	1.5596552	.841825	20			40	.702981	.988432	1.0117088	.711209	20	
	50	.542197	.645280	1.5497155	.840251	10			50	.705047	.994199	1.0058348	.709161	10	
33	0	.544639	.649408	1.5398650	.838671	0	57	45	0	.707107	1.000000	1.0000000	.707107	0	45
	10	.547076	.653551	1.5301025	.837083	50				—	—	—	—	50	
	20	.549509	.657710	1.5204261	.835488	40				—	—	—	—	40	
	30	.551937	.661886	1.5108352	.833886	30				—	—	—	—	30	
	40	.554360	.666077	1.5013282	.832277	20				—	—	—	—	20	
	50	.556769	.670285	1.4919039	.830661	10	56	—		—	—	—	—	10	
°	'	Cosine	Cotan.	Tan.	Sine	°	'	°	'	Cosine	Cotan.	Tan.	Sine	°	'

NOTE: For functions from 45°-0' to 68° read from bottom of table upward.

# WORMS & WORM GEARS

Basic diameters and tooth parts of a stock worm gear.

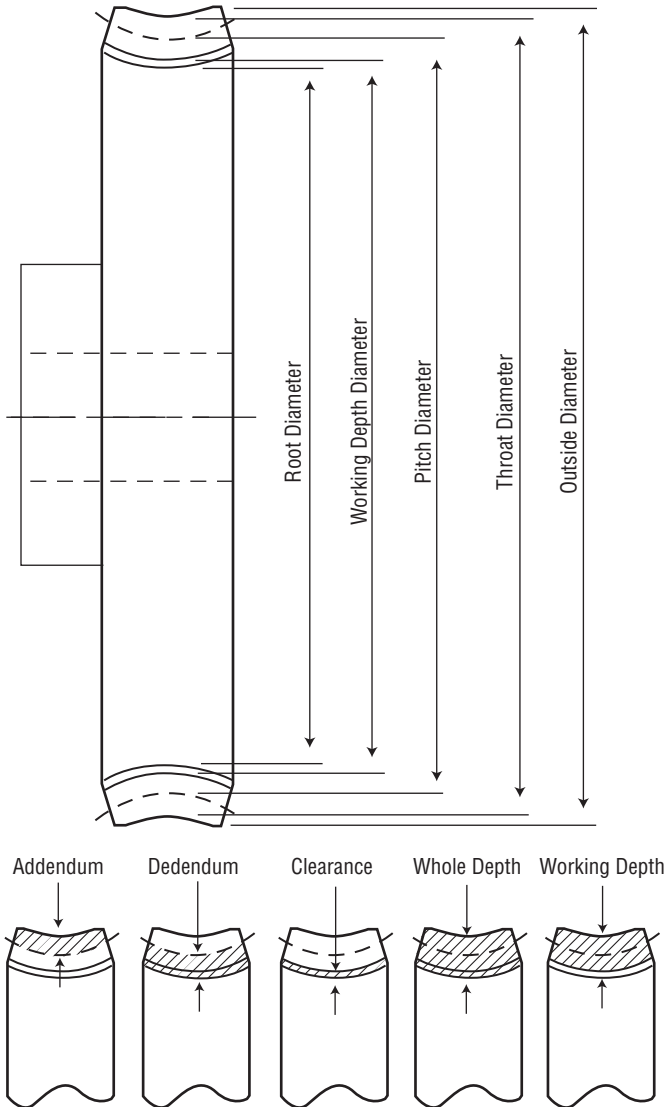

## PITCH

All *Martin* stock worm gears are listed by their diametral pitch.

Diametral pitch of a worm gear is defined as the number of teeth in the gear per one inch of pitch diameter. It can be determined by the formula:

$$\text{Dia. Pitch} = \frac{\text{Number of Teeth}}{\text{Pitch Dia.}}$$

Circular Pitch of a worm gear is determined by the

same method as used in spur gears. It is a measurement, in inches, along the pitch circle between corresponding points on adjacent teeth.

The formula for determining circular pitch (CP) is:

$$\text{CP} = \frac{\text{Pitch dia.} \times \pi}{\text{Number of Teeth}}$$

The relationship between circular pitch (CP) and diametral pitch (DP) is shown in the following formulas:

$$\text{CP} = \frac{\pi}{\text{DP}}$$

$$\text{DP} = \frac{\pi}{\text{CP}}$$

$$\text{DP} \times \text{CP} = \pi$$

The pressure Angle of all *Martin* stock worms and worm gears are either 14-1/2 degrees or 20 degrees as shown in the catalog.

A worm and worm gear operating on proper centers must be of the same:

Pitch

Pressure Angle

Number of Threads

Helix Angle

Hand (Right or Left)

Tooth Proportions

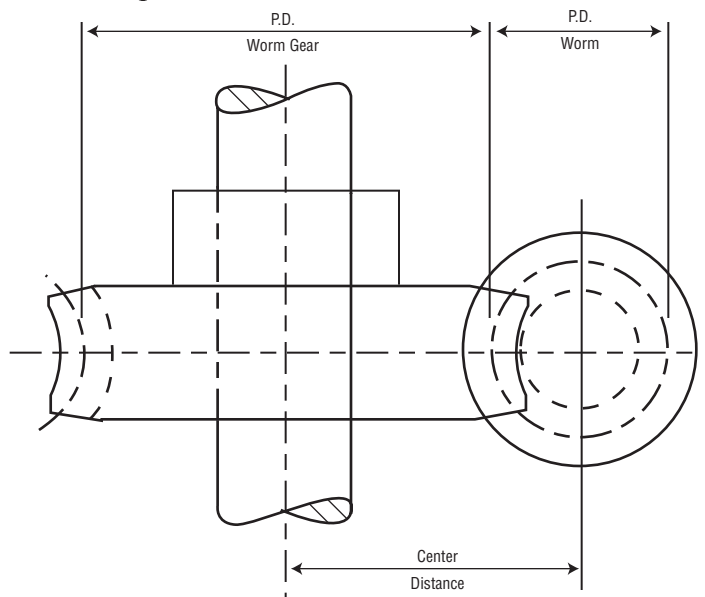

The center distance is the measurement in inches from center to center of the two right angle shafts on which the worm and worm gear are mounted.

Proper centers for all *Martin* stock worm and worm gear sets are shown in the catalog in the third vertical column reading across from desired worm gear.

Center distance is determined by the formula:

$$\text{C.D.} = \frac{\text{P.D. of worm} + \text{P.D. of gear}}{2}$$

Worms and worm gears are most often used to provide a large ratio of reduction in a relatively small space. The ratio of a worm and worm gear set is determined by the following formula:

$$\text{Ratio} = \frac{\text{Number of gear teeth}}{\text{Number of worm threads}}$$

*Note: Refer to page 24 of this manual to determine the number of threads.*

**EXAMPLE:**

A 6 DP, 60 tooth worm gear has a 10" P.D. and a 6 DP worm has a 2" P.D. Regardless of number of threads or helix angle this set will operate on 6" centers.

*Using formula*

$$\text{C.D.} = \frac{\text{P.D. of worm} + \text{P.D. of gear}}{2}$$

OR

$$\frac{2'' + 10}{2} = 6'' \text{ C.D.}$$

*Using formula*

$$\text{Ratio} = \frac{\text{Number of gear teeth}}{\text{Number of worm thread}} = \text{What would}$$

the ratios be using a single - double triple and quad. thread worms & gears.

Single- Ratio =  $\frac{60}{1} = 60 \text{ to } 1$

Double - Ratio =  $\frac{60}{2} = 30 \text{ to } 1$

Triple - Ratio =  $\frac{60}{3} = 20 \text{ to } 1$

Quad.- Ratio =  $\frac{60}{4} = 15 \text{ to } 1$

Backlash in a worm and worm gear set is the space between the backside (non-driving side) of a worm thread and the gear tooth behind it. The amount of accumulative backlash of a set can be felt by holding the worm shaft in a fixed position and rotating the gear shaft back and forth. For most

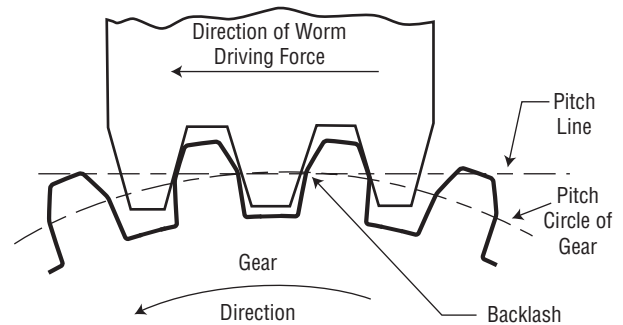

worm reducers the backlash is 1/2°.

Backlash is cut into a set to provide proper running clearance and adequate lubrication between gear tooth and worm threads. It will also ensure maximum efficiency and a smooth running set.

Although proper backlash is cut into a worm and gear set during manufacture it cannot be maintained unless the set is installed on proper centers.

When installed on centers which are too close, the set will bind not permitting sufficient clearance for lubricating gear teeth and worm threads. This condition will cause excessive heat and tooth wear. When installed on centers which are too great, excessive backlash will result. This will cause excessive noise and possibly vibration. Improper running characteristics such as these will shorten the life of the set.

# WORMS & WORM GEARS

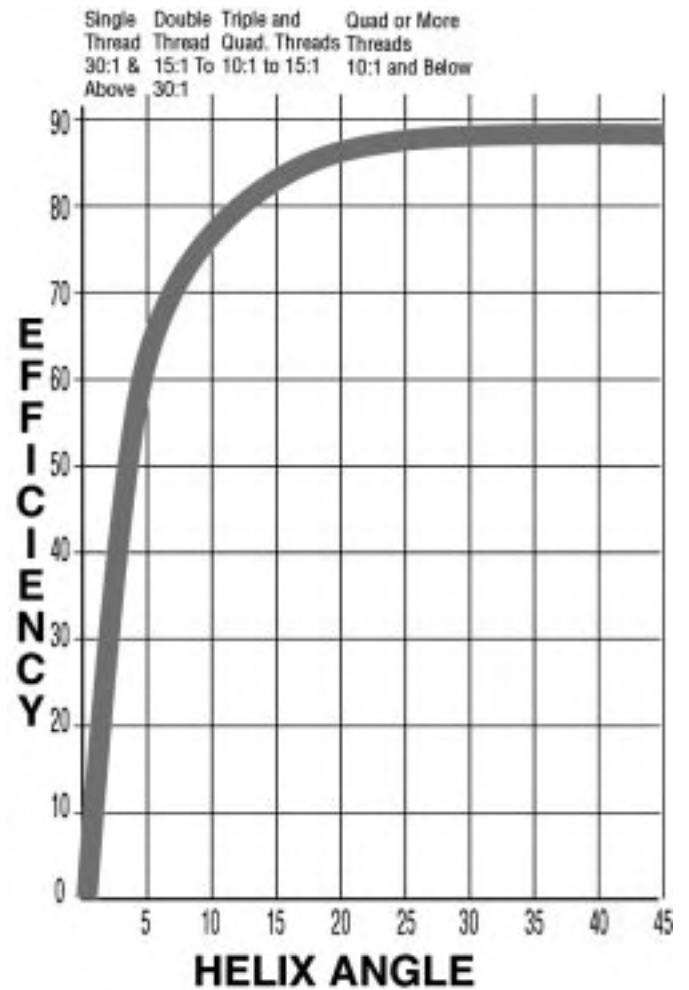
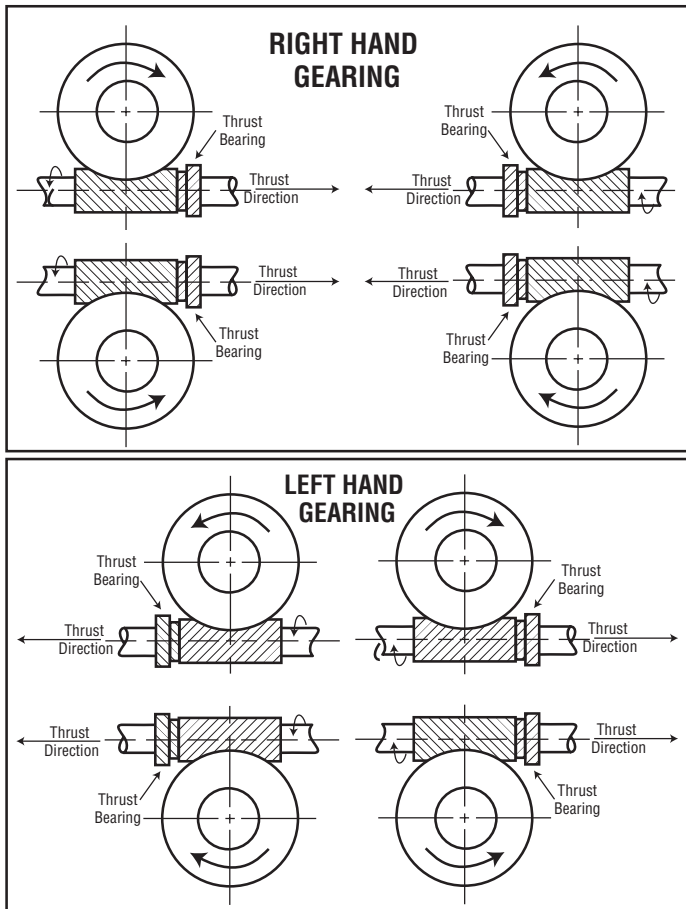

## EFFICIENCY

A worm and worm gear drive is probably the least efficient of all type gearing due to the sliding action of the worm across the teeth of the gear. This sliding action causes a definite loss of power, or efficiency, through friction. While there are many factors which increase or decrease the amount of friction loss, such as materials used, surface finishes, accuracy of cutting, worm speed, lubrication, and loading; the factor having the most pronounced effect is the helix angle of the worm.

The general rule is: The greater the helix angle, the greater the efficiency. It, therefore, can be said the greater the number of threads in the worm, the greater the helix angle, resulting in greater efficiency.

The following curve chart shows the approximate relationship of helix angle, number of threads in worm, and efficiency.

## SELF - LOCKING

As the lead angle of a worm gear set increases, so does the efficiency. This is true for several reasons. For a higher lead angle, the tooth load component causing friction is reduced. With reduced pressure the coefficient of friction is decreased. Lubrication is also more easily permitted to enter the tooth mesh with lower tooth pressure. Within reasonable limits, tests have shown that coefficient of friction decreases with increased rubbing speeds such as are inherent with higher lead angles.

Self-locking occurs mathematically when the coefficient of friction is greater than the tangent of the lead angle. This condition precludes the worm gear "back driving" the worm. This generally occurs at lead angles of approximately 5° or less. This feature can be useful for applications such as hoists where it is desirable to have the worm gear remain at rest once positioned by the worm.

Extreme caution should be exercised in terming a particular worm gear self-locking for all conditions. Vibration can cause a worm gear set that is statically self-locking to “crawl”. Border line self-locking sets tend to lose this characteristic once they are “polished in”.

Certain worm gearing is useful for dynamic braking; however, self-locking sets are to be avoided when heavy inertial loads such as flywheels are to be driven since heavy tooth loading results where worm driving power is interrupted.

Always refer to low lead angle (5° and under) worm gearing as “Nominally” self-locking and suggest that positive self-locking be accomplished by the use of a brake or other mechanical means.

### HORSEPOWER & TORQUE RATINGS

In the current *Martin* catalog there are 26 pages of load ratings for stock worms and worm gears showing horsepower, torque, and efficiency. For this reason they will not be duplicated in this manual, however, the following information should be noted.

There is no accepted formula for calculating ratings of cast iron gear and soft steel worms. The catalog ratings are for hardened steel worms operating

with bronze gears only. To estimate ratings of soft worms and cast iron gears 50% of these ratings may be used.

Cast iron gears and soft steel worms are normally used for hand operated equipment or slow speed operations where light loading is encountered.

It should be noted that ratings as shown in *Martin* Catalog 2001 are for Class I service. In making

CLASSIFICATION	APPLICATION	SERVICE FACTOR
Class I	Continuous 8 to 10 hour service with no shock load.	1.0
Class II	Continuous 8 to 10 hour with recurrent shock load, or continuous 24 hour service with no shock load.	1.2
Class III	Continuous 24 hour service with shock load.	1.3
Class IV	Intermittent duty with worm speed of 100 RPM or more.	0.7
Class V	Slow speed service with worm speed less than 100 RPM.	Use torque rating only to make selection.

selection, proper service factor should be applied.

To use service factors multiply actual H.P. or torque by service factor. This will produce corrected H.P. or torque requirement. Select gearing according

## FORMULA FOR WORM GEARS

(Based On Diametral Pitch)

TO FIND	RULE	FORMULA
Worm Gear Pitch Diameter	Divide No. of Teeth by Diametral Pitch	Pitch Dia. = $\frac{\text{No. Teeth in Worm Gear}}{\text{Dia. Pitch}}$
Worm Gear Throat Diameter	Add 2 Addenda to Pitch Diameter	Throat Dia. = (2 x Addendum) + Pitch Dia.
Worm Gear O. Diameter	Add 3 Addenda to Pitch Diameter	O. Dia. = (3 x Addendum) + Pitch Dia.
Worm Pitch Diameter	Subtract the Worm Gear Pitch Diameter from Twice the Center Distance	Worm Pitch Dia. = (2 x Center Distance) - Worm Gear Pitch Dia.
Worm O. Diameter	Add 2 Addenda to Worm Pitch Diameter	Worm O. Dia. = Worm Pitch Dia. + 2 x Addendum
Worm Lead	Divide 3.1416 by Diameter Pitch and Multiply by Number Threads in Worm	Worm Lead = $\frac{3.1416}{\text{Dia. Pitch}} \times \text{No. Threads in Worm}$
Co-Tangent of Worm Helix Angle	Multiply Worm Pitch Diameter by Diametral Pitch and Divide by Number Worm Threads	Co-Tangent Worm Helix Angle = $\frac{\text{Worm Pitch Dia.} \times \text{Dia. Pitch}}{\text{No. Worm Threads}}$
Center Distance	Add Worm Pitch Diameter to Worm Gear Pitch Diameter and Divide Sum by 2	Center Distance = $\frac{\text{Worm Pitch Dia.} + \text{W. Gear Pitch Dia.}}{2}$
Ratio	Divide No. Teeth in Worm Gear by Number of Worm Threads	Ratio = $\frac{\text{No. Teeth in Worm Gear}}{\text{No. Worm Threads}}$

NOTE: TOOTH DATA (ADDENDUM, FULL DEPTH, ETC.) IS SAME AS FOR SPUR GEARS

# BEVEL & MITER GEARS

## BEVEL GEARS

Bevel gears and pinions, like spur gears, are made up of several basic circles. However, unlike a spur gear, the tooth portion of the bevel is in the shape of a section of a cone.

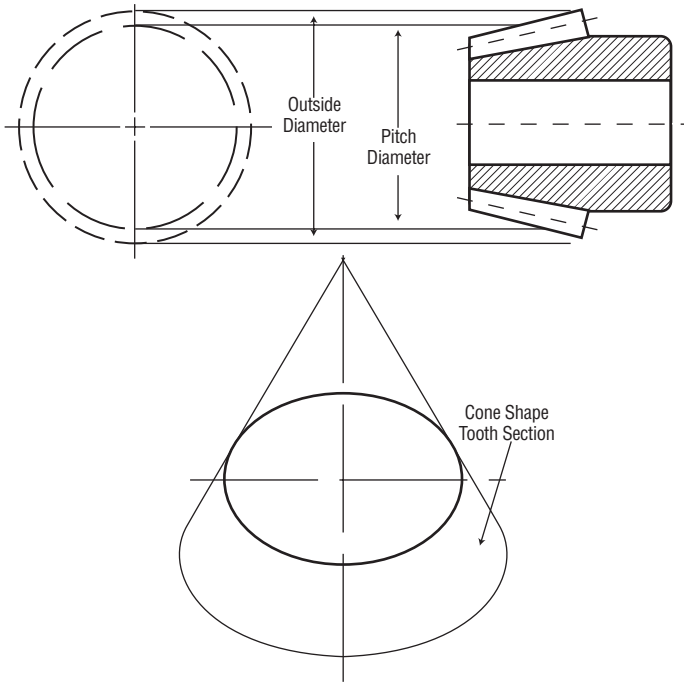

*Martin* stock bevel gear sets are designed to connect shafts that are on the same plane and at an angle of 90° to each other.

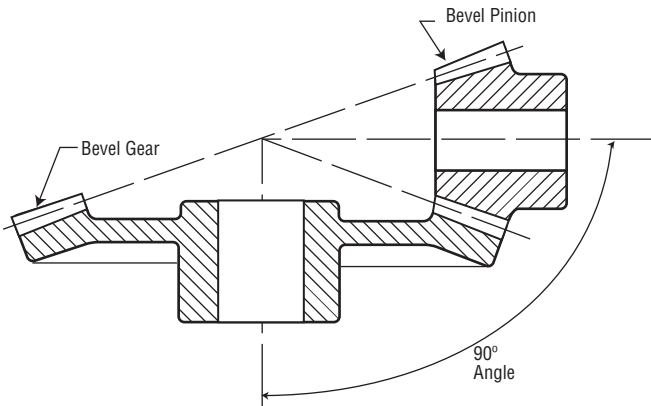

Since the bevel gear is always greater in pitch diameter and number of teeth than the bevel pinion, there is always a ratio greater than 1:1. It can, therefore, be said that a *Martin* bevel set is used to transmit power or motion at a 90° angle with a decrease

or increase of speed.

The following are formulae involving ratio:

$$\text{Ratio} \quad \frac{N_g}{n_p} = \frac{\text{rpm}_p}{\text{RPM}_g} = \frac{\text{P.D.}_g}{\text{p.d.}_p}$$

$$N_g = n_p \times \text{Ratio} \quad n_p = \frac{N_g}{\text{Ratio}}$$

$$\text{RPM}_g = \frac{\text{rpm}_p}{\text{Ratio}} \quad \text{rpm}_p = \text{RPM}_g \times \text{Ratio}$$

$$\text{P.D.}_g = \text{p.d.}_p \times \text{Ratio} \quad \text{p.d.}_p = \frac{\text{P.D.}_g}{\text{Ratio}}$$

*NOTE: SPECIAL BEVEL SETS CAN BE PRODUCED TO OPERATE AT ANGLES OTHER THAN 90°.*

### EXAMPLE

A bevel pinion having 18 teeth and a pitch diameter of 1-1/2" is turning at 1200 rpm and is driving a bevel gear with 54 teeth. Determine the pitch diameter and the rpm of the gear.

$$\text{Ratio} \quad \frac{N_g}{n_p} = \frac{54}{18} = 3:1$$

$$\text{RPM}_g = \frac{\text{rpm}_p}{\text{Ratio}} = \frac{1200}{3} = 400$$

$$\text{P.D.}_g = \text{p.d.}_p \times \text{Ratio} = 1.5" \times 3 = 4.5"$$

### PITCH AND TOOTH PARTS

All *Martin* bevel gears and pinions are listed in the catalog by their diametral pitch. To calculate the diametral pitch (D.P.) of a bevel gear the same method is used as for spur gears.

$$\text{D.P.} = \frac{N_t}{\text{P.D.}}$$

The above formula indicates D.P. of a bevel to be the number of teeth per one inch of pitch diameter.

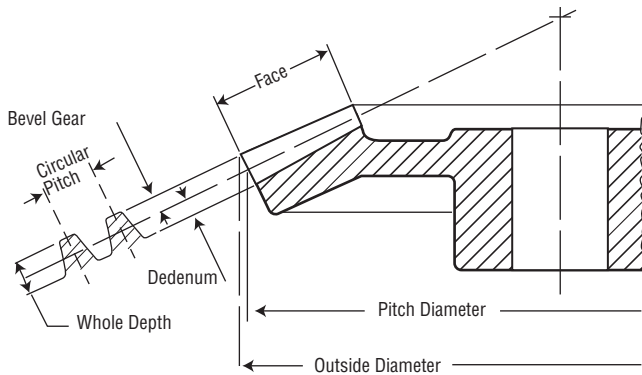

The Circular Pitch of a bevel gear may be found by measuring from a point on one tooth along the pitch line AT THE LARGE END OF THE TEETH to the same point on an adjacent tooth.

Circular Pitch is illustrated in the above sketch. Also illustrated are Addendum, Dedendum, and Whole Depth. A study of these tooth parts will reveal their sizes are also determined at the large end or outside edge of the tooth.

Bevel gears and pinions shown in the *Martin* catalog are of the “Gleason System”. Bevel sets produced by this system are described as having long and short addendums and being of the CONIFLEX® tooth design.

In a mating bevel gear and pinion, the pinion has a long addendum and the gear a short addendum. The difference in length varies with the ratio. For instance, in a miter gear set where the ratio is 1:1 the addendums, using this system, would be equal. However, as the ratio increases, the addendum of the bevel pinion would increase in length and the addendum of the gear would decrease proportionately as the whole depth and clearance remain constant.

Bevel gear sets produced by this method offer greater strength and durability. They will operate with less noise than those having equal addendums and not of the CONIFLEX® tooth form.

By having long addendums on the pinion, undercut is avoided and tooth strength is increased. Since the addendum of the gear is reduced, the life and strength of the set tend to balance.

The following should be noted from the preceding sketch.

### ADDENDUM:

The addendum is the portion of the tooth between

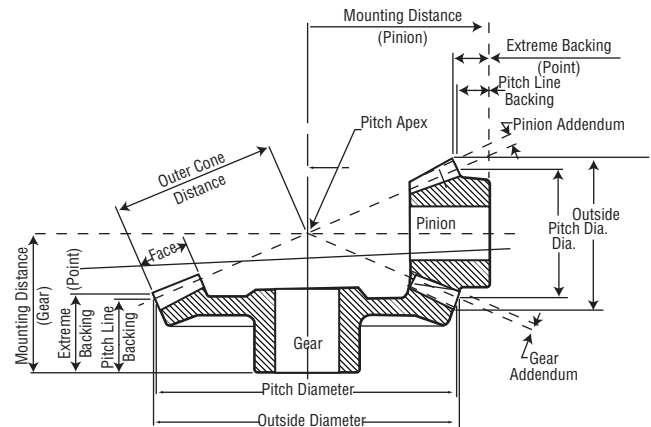

the pitch circle and the outside circle measured at the large end, or outside edge, of the tooth. It should be noted in this illustration that the pinion has a long addendum and the gear a short addendum while the whole depth of both are equal.

### MOUNTING DISTANCE:

The mounting distance of the pinion is measured from the pitch apex to the back end of the pinion hub.

The mounting distance of the gear is measured from the pitch apex to the back end of the gear hub.

The length through the bore may be made longer or shorter by adding or removing material from the front, or small end of the gear and/or pinion without changing the mounting distance.

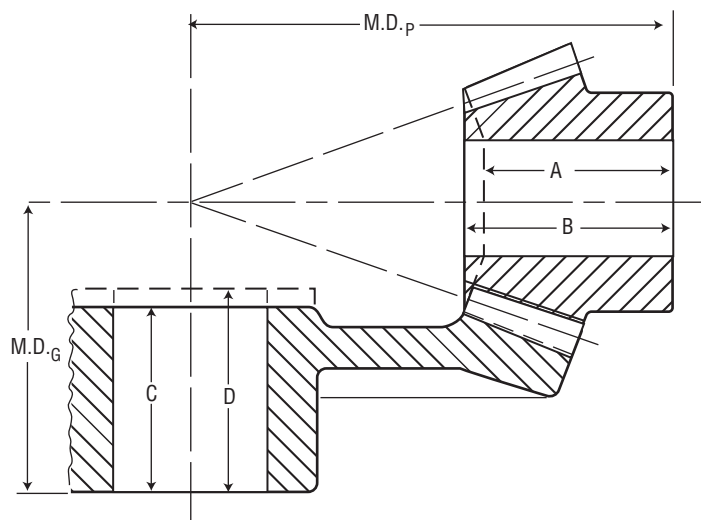

The illustration above shows the pinion having two lengths through bore (A & B), and gear having two (C & D), with pinion mounting distance (M.D.p) and gear mounting distance (M.D.G) remaining constant.

# BEVEL & MITER GEARS

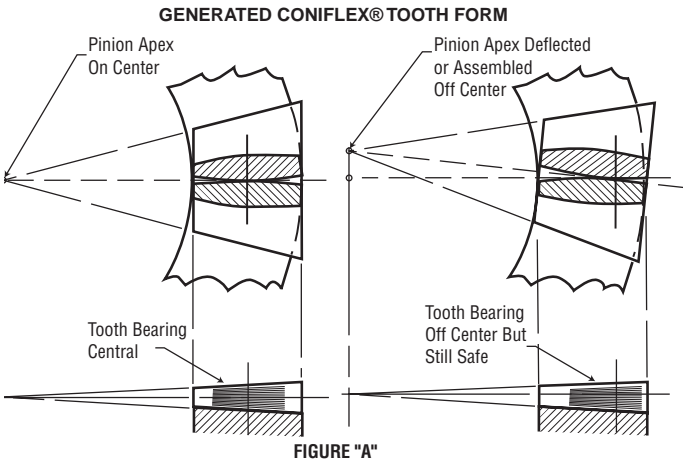

FIGURE "A"

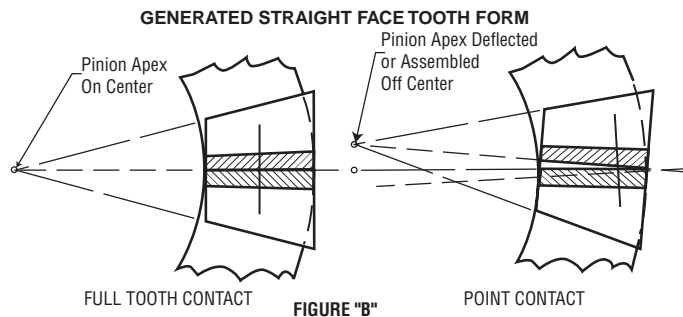

FIGURE "B"

The illustration above shows the effect of misalignment on the bearing pattern for a bevel gear and pinion cut with both the CONIFLEX® tooth form and the old style, straight face, tooth form.

**Figure A** shows a top view of a bevel gear tooth and a bevel pinion tooth which reveals the curvature of the CONIFLEX® tooth form. The sketch at the left indicates the usual operating position of the set, while the sketch at the right indicates the position after a displacement, or due to misalignment at assembly.

**Figure B** shows the same operating positions for straight face generated teeth.

In studying the two, it is evident that misalignment of the CONIFLEX® gear will position the load off center but the amount of load bearing surface remains adequate and the load is not concentrated at the ends of the teeth. With the straight face tooth, the load is carried across the full length of the tooth when alignment is perfect but any slight misalignment will transfer the load to the very end of the tooth offering only a small area as a load carrying surface.

A bevel gear set of CONIFLEX® tooth form then

will continue to run smoothly and quietly with a safe load distribution even under conditions of slight misalignment.

It should be noted, that a gear or pinion cut with the CONIFLEX® tooth form will operate with a gear or pinion having straight face. However, only partial benefits will be gained.

Also, a gear or pinion having long or short addendums will not operate properly with a gear or pinion having equal addendums.

The horsepower ratings for *Martin* stock bevel sets in this manual, and in the catalog, are based on the Gleason long and short addendum system and the CONIFLEX® tooth form.

## BEVEL GEAR NOMENCLATURE (Gleason System)

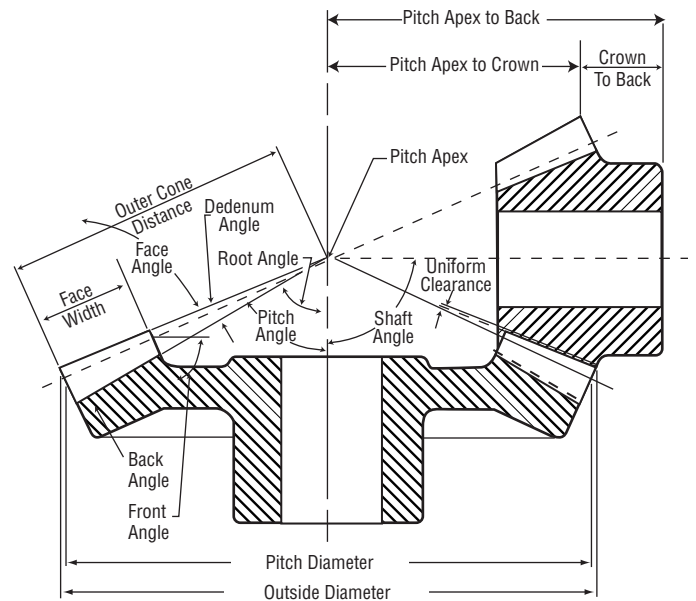

## RELATIVE ROTATION - THRUST

Earlier it was stated that a *Martin* bevel set is used to transmit power or motion at a 90 degree angle with an increase or decrease of speed. It may also be said they can reverse the direction of shaft rotations.

The next sketch shows in this position, looking at the hub ends, the pinion shaft is turning counter-clockwise while the gear shaft is turning clockwise. If the pinion is placed on the other side of the gear, and the pinion shaft continues to turn in the same

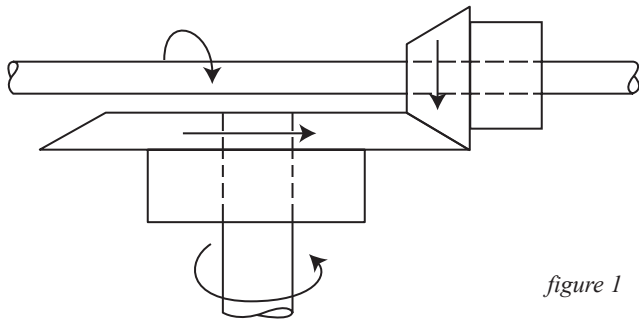

figure 1

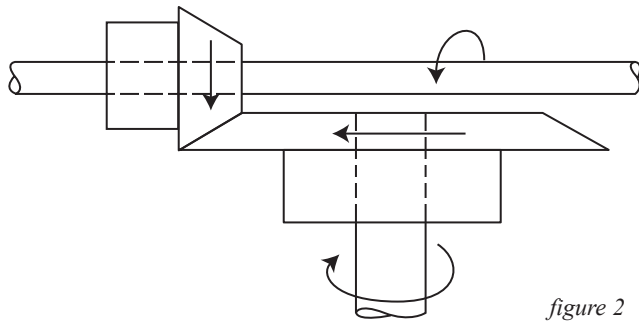

figure 2

direction, the direction of rotation of the gear shaft will reverse. (see figure 2)

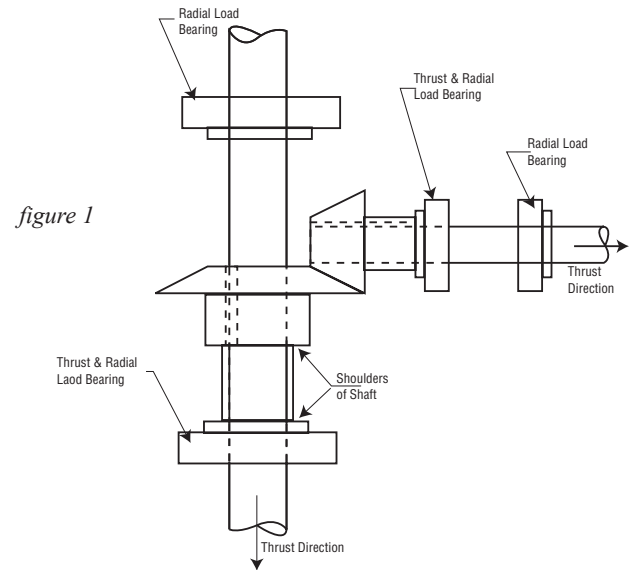

figure 1

## BEVEL & MITER GEAR FORMULAS

TO FIND	RULE	FORMULA
Pitch Diameter	Divide Number of Teeth By Diametral Pitch	$\text{Pitch Diameter} = \frac{\text{No. Teeth}}{\text{Dia. Pitch}}$
Tangent of Pitch Angle of Driven	Divide Number of Teeth In Driven By Number of Teeth in Driver	$\text{Tan. Pitch Angle of Driven} = \frac{\text{No. Teeth in Driven}}{\text{No. Teeth in Driver}} = \text{Ratio}$
Pitch Angle of Driver	Subtract Pitch Angle of Driven from 90 Degrees	$\text{Pitch Angle of Driver} = 90 \text{ Deg.} - \text{Pitch Angle of Driven}$
Pitch Cone Radius	Divide Pitch Diameter by Twice the Sine of the Pitch Angle	$\text{Pitch Cone Radius} = \frac{\text{Pitch Diameter}}{2 \times \text{Sine Pitch Angle}}$
Tangent of Addendum Angle	Divide Addendum by the Pitch Cone Radius	$\text{Tangent of Add. Angle} = \frac{\text{Addendum}}{\text{Pitch Cone Radius}}$
Face Angle	Add Addendum to The Pitch Angle	$\text{Face Angle} = \text{Add. Angle} + \text{Pitch Angle}$
Tangent of Dedendum Angle	Divide Dedendum by the Pitch Cone Radius	$\text{Tangent of Ded. Angle} = \frac{\text{Dedendum}}{\text{Pitch Cone Radius}}$
Root Angle	Subtract Dedendum Angle from Pitch Angle	$\text{Root Angle} = \text{Pitch Angle} - \text{Dedendum Angle}$
Angular Addendum	Multiply Addendum by Cosine Of Pitch Angle	$\text{Angular Addendum} = \text{Addendum} \times \text{Cosine Pitch Angle}$
Outside Diameter	Add 2 Angular Addenda to Pitch Diameter	$\text{O. Diameter} = 2 \text{ Angular Add.} + \text{Pitch Diameter}$
Mounting Distance	Add One Half the Pitch Diameter of Mating to Pitch Line	$\text{Mounting Distance} = \frac{\text{Pitch Diameter Of Mate}}{2} + \text{Backing To Pitch Line}$
Distance from Cone Center to Crown	Multiply One Half O. Diameter by Co-tangent of Face Angle	$\text{Cone Center To Crown} = \frac{\text{O. Diameter}}{2} \times \text{Co-tangent Face Angle}$
Backing To Crown	Subtract Cone Center to Crown from Mounting Distance	$\text{Backing To Crown} = \text{Mounting Distance} - \text{Cone Center To Crown}$
Ratio	Divide Teeth in Driven by Teeth in Driver	$\text{Ratio} = \frac{\text{No. Teeth In Driven}}{\text{No. Teeth in Driver}}$

## BEVEL & MITER GEARS

---

When a bevel gear and pinion are connecting two intersecting right angle shafts, and are under load, they tend to push away from each other, or separate. This action is termed THRUST .

Regardless of the assembly, straight tooth bevel sets the DIRECTION OF THRUST, for both pinion and gear, is always **BACKWARD TOWARD THE HUB**

The thrust load of a bevel gear set must always be compensated for with bearings having adequate thrust capacity and properly positioned on the shafts.

The sketch on the preceding page shows a typical arrangement of bevel gears and tapered roller bearings.

The pinion is mounted on the end of a shaft being supported by two opposing roller bearings. The thrust is being taken by the bearing on the left as the hub is mounted against the cone. Both bearings will support the radial load and the one on the right will accept any overhung load imposed on the shaft to its right side (or outboard).

The gear is mounted between two tapered roller bearings and against a shoulder on the shaft. The shoulder holds the gear in proper mesh. Since the direction of thrust is down, the bottom bearing must accept the thrust load. Here again, the radial load is supported by both bearings.

Calculation of bevel gear thrust will not be dealt with in this manual due to its complexity. It is recommended that only qualified engineers and designers make bearing selections for this type gearing. To assist in bearing selections load computation manuals may be obtained from most bearing manufacturers.



# BEVEL & MITER GEARS

## Cast Iron

Catalog Number	Revolutions per Minute							
	50	100	200	300	600	900	1200	1800
B330-2	2.5	4.5	7.7	10.0	15.3			
B315-2	2.5	4.5	7.7	10.0	15.3			
B432-2	1.33	2.3	4.0	5.3	8.0	9.5		
B416-2	1.33	2.3	4.0	5.3	8.0	9.5		
B442-3	1.10	2.0	3.7	5.0	7.5	9.0		
B414-3	1.10	2.0	3.7	5.0	7.5	9.0		
B456-4	1.4	2.5	4.4	6.0	9.0	10.9		
B414-4	1.4	2.5	4.4	6.0	9.0	10.9		
B530-2	.5	1.0	1.9	2.5	3.9	4.8	5.5	
B515-2	.5	1.0	1.9	2.5	3.9	4.8	5.5	
B545-3	.7	1.4	2.4	3.3	5.2	6.4	7.2	
B515-3	.7	1.4	2.4	3.3	5.2	6.4	7.2	
B560-4	1.0	1.8	3.3	4.4	6.9	8.4	9.5	
B515-4	1.0	1.8	3.3	4.4	6.9	8.4	9.5	
B636-2	.5	1.0	1.7	2.3	3.7	4.4	5.0	
B618-2	.5	1.0	1.7	2.3	3.7	4.4	5.0	
B642-2	.6	1.1	2.0	2.7	4.0	5.0		
B621-2	.6	1.1	2.0	2.7	4.0	5.0		
B645-3	.4	.8	1.4	2.0	3.2	3.9	4.6	
B615-3	.4	.8	1.4	2.0	3.2	3.9	4.6	
B648-2	.8	1.5	2.5	3.4	5.1	6.1		
B624-2	.8	1.5	2.5	3.4	5.1	6.1		
B660-4	.5	.9	1.7	2.3	3.7	4.6	5.2	
B615-4	.5	.9	1.7	2.3	3.7	4.6	5.2	
B840-2	.4	.7	1.3	1.8	2.9	3.7	4.2	
B820-2	.4	.7	1.3	1.8	2.9	3.7	4.2	
B848-3	.2	.4	.7	1.0	1.7	2.2	2.5	2.9
B816-3	.2	.4	.7	1.0	1.7	2.2	2.5	2.9
B864-4	.2	.4	.7	1.0	1.7	2.2	2.5	
B816-4	.2	.4	.7	1.0	1.7	2.2	2.5	
B872-4	.4	.7	1.2	1.8	2.8	3.6	4.2	
B818-4	.4	.7	1.2	1.8	2.8	3.6	4.2	
B1060-3	.17	.3	.6	.8	1.3	1.7	1.9	2.3
B1020-3	.17	.3	.6	.8	1.3	1.7	1.9	2.3
B1060-4	.1	.2	.4	.5	.9	1.2	1.4	1.8
B1015-4	.1	.2	.4	.5	.9	1.2	1.4	1.8
B1090-6	.14	.25	.5	.7	1.2	1.7	1.9	2.3
B1015-6	.14	.25	.5	.7	1.2	1.7	1.9	2.3
B1236-2	.05	.11	.2	.3	.5	.6	.8	1.0
B1218-2	.05	.11	.2	.3	.5	.6	.8	1.0
B1254-3	.07	.15	.3	.4	.7	.9	1.0	1.3
B1218-3	.07	.15	.3	.4	.7	.9	1.0	1.3
B1272-4	.07	.15	.3	.4	.7	.9	1.1	1.4
B1218-4	.07	.15	.3	.4	.7	.9	1.1	1.4
B1272-6	.06	.11	.2	.3	.6	.8	1.0	1.2
B1212-6	.06	.11	.2	.3	.6	.8	1.0	1.2

## Steel

Catalog Number	Revolutions per Minute							
	50	100	200	300	600	900	1200	1800
BS636-2	.9	1.7	3.0	4.1	6.4	8.0	9.0	
BS618-2	.9	1.7	3.0	4.1	6.4	8.0	9.0	
BS840-2	.5	.9	1.5	2.1	3.5	4.4	5.0	
BS820-2	.5	.9	1.5	2.1	3.5	4.4	5.0	
BS1030-15	.2	.4	.7	1.0	1.7	2.1	2.3	2.9
BS1020-15	.2	.4	.7	1.0	1.7	2.1	2.3	2.9
BS1040-2	.25	.5	.9	1.3	2.1	2.7	3.0	3.7
BS1020-2	.25	.5	.9	1.3	2.1	2.7	3.0	3.7
BS1050-2	.33	.64	1.2	1.6	2.5	3.2	3.7	
B 1025-2	.33	.64	1.2	1.6	2.5	3.2	3.7	
BS1060-3	.3	.5	1.0	1.4	2.4	3.0	3.5	4.3
BS1020-3	.3	.5	1.0	1.4	2.4	3.0	3.5	4.3
BS1227-15	.09	.17	.33	.5	.8	1.0	1.2	1.6
BS1218-15	.09	.17	.33	.5	.8	1.0	1.2	1.6
BS1236-2	.12	.25	.4	.6	1.0	1.4	1.7	2.0
BS1218-2	.12	.25	.4	.6	1.0	1.4	1.7	2.0
BS1236-2A	.12	.25	.4	.6	1.0	1.4	1.7	2.0
BS1218-2A	.12	.25	.4	.6	1.0	1.4	1.7	2.0
BS1248-2	.18	.37	.7	.9	1.6	2.0	2.3	2.8
B1224-2	.18	.37	.7	.9	1.6	2.0	2.3	2.8
BS1254-3	.14	.28	.5	.7	1.2	1.6	1.9	2.3
B1218-3	.14	.28	.5	.7	1.2	1.6	1.9	2.3
BS1428-2	.05	.08	.16	.20	.40	.54	.7	.8
BS1414-2	.05	.08	.16	.20	.40	.54	.7	.8
BS1624-2	.02	.03	.05	.08	.14	.20	.25	.3
BS1612-2	.02	.03	.05	.08	.14	.20	.25	.3
BS1624-15	.03	.05	.09	.14	.25	.33	.4	.5
BS1612-15	.03	.05	.09	.14	.25	.33	.4	.5
BS1632-2	.03	.08	.14	.20	.37	.5	.6	.8
BS1616-2	.03	.08	.14	.20	.37	.5	.6	.8
BS1648-3	.05	.09	.17	.25	.50	.6	.8	1.0
BS1616-3	.05	.09	.17	.25	.50	.6	.8	1.0
BS1664-4	.05	.10	.20	.33	.50	.7	.9	1.1
BS1616-4	.05	.10	.20	.33	.50	.7	.9	1.1

# MITER GEARS

## MITER GEARS

Working Depth = 2 Addendums

Miter gears, for all purpose of design and application, are considered to be bevel gears with a 1:1 ratio. To run together they must be of the same pitch and have the same pressure angle and number of

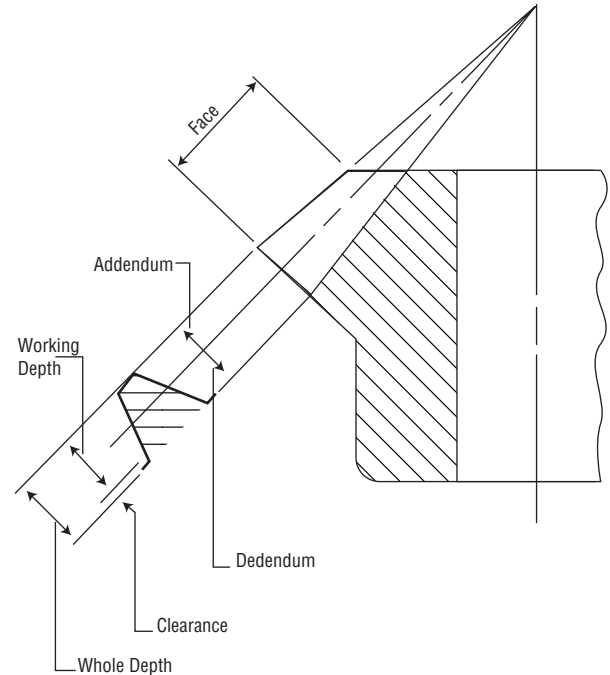
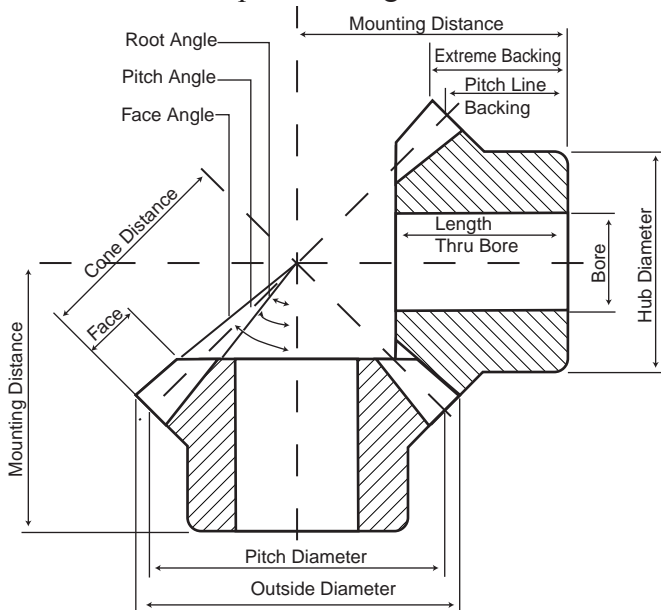

teeth.

*Martin* miter gears are cut with the Gleason CONIFLEX® tooth form; however, since they are 1:1 ratio they have equal addendums. It is, therefore, possible to use the following rules to determine pitch and tooth proportions.

$$\text{Diametral Pitch (D.P.)} = \frac{\pi}{\text{Circular Pitch (C.P.)}}$$

$$\text{Circular Pitch (C.P.)} = \frac{\pi}{\text{Diametral Pitch (D.P.)}}$$

$$\text{Pitch Diameter (P.D.)} = \frac{\text{Number of Teeth (Nt)}}{\text{D.P.}}$$

$$\text{Whole Depth} = \frac{2.188}{\text{D.P.}} + .002$$

$$\text{Addendum} = \frac{1}{\text{D.P.}}$$

$$\text{Dedendum} = \frac{2.188}{\text{D.P.}} - \text{Addendum}$$

$$\text{Clearance} = \frac{.188}{\text{D.P.}} + .002$$

## HORSEPOWER RATINGS

*Martin* stock miter gears are available in either soft .40 carbon steel or with hardened teeth only.

The following ratings show both soft and hardened gear.

Hardened gears have suffix “H” indicating hardened teeth only - plain bore.

Hardened gears having suffix “HK” indicate hardened teeth only - keyway and set screw.

When more than one bore size is available - additional sizes are shown.

Caution should be exercised in using these ratings for gears produced by other manufacturers since *Martin*'s soft miter gears are produced from .40 carbon steel having 120,000 p.s.i. tensile strength rating. Tooth strength and durability for gears produced from .20 carbon steel are rated considerably less. i.e. 1020 is 60 - 80,000 p.s.i. tensile strength.



# MITER GEAR

## Steel

Catalog Number	Revolutions Per Minute									
	10	25	50	100	200	300	600	900	1200	1800
M424	.80	1.90	3.6	6.4	10.6	13.5	18.8	21.5	23.0	
HM424	1.40	3.33	6.3	11.2	18.6	23.6	33.0	38.0	40.0	
M428	1.07	2.50	4.8	8.4	13.6	17.2	23.3	26.5	28.5	
HM428	1.90	4.50	8.4	14.7	23.8	30.0	40.0	46.0	50.0	
M525	.45	1.05	2.0	3.7	6.3	8.1	11.6	13.6	15.0	
HM525	.75	1.90	3.6	6.5	11.0	14.2	20.0	24.0	26.0	
M624	.25	.55	1.1	2.0	3.5	4.6	6.9	8.2	19.0	10.2
HM624	.40	1.00	1.9	3.5	6.1	8.0	12.0	14.5	16.0	18.0
M627	.30	.75	1.4	2.5	4.3	5.7	8.5	9.9	11.0	12.0
HM627	.50	1.33	2.5	4.4	7.5	10.0	1.5	17.5	19.0	21.0
M824	.10	.25	.5	.9	1.5	2.1	3.3	4.0	4.5	5.3
HM824	.20	.40	.8	1.5	2.6	3.7	5.8	7.0	8.0	9.3
M828	.15	.33	.7	1.2	2.2	2.9	4.4	5.3	6.0	6.8
HM828	.25	.60	1.2	2.1	3.9	5.0	7.7	9.3	10.5	12.0
M832	.20	.45	.9	1.6	2.8	3.7	5.5	6.5	7.2	8.0
HM832	.33	.80	1.5	2.8	4.9	6.5	9.6	11.4	12.5	14.2
M1020	.03	.08	.2	.3	.6	.8	1.3	1.7	2.0	2.4
HM1020	.05	.15	.3	.5	1.0	1.4	2.3	3.0	3.5	4.2
M1025	.06	.15	.3	.5	.9	1.3	2.0	2.5	2.9	3.5
HM1025	.10	.25	.5	.9	1.6	2.3	3.5	4.4	5.0	6.0
M1030	.08	.20	.4	.7	1.3	1.8	2.8	3.5	3.9	4.5
HM1030	.15	.33	.7	1.3	2.3	3.2	4.9	6.1	6.8	8.0
M1215	.01	.02	.05	.10	.20	.3	.5	.6	.8	.9
HM1215	.02	.04	.10	.17	.33	.4	.8	1.0	1.3	1.6
M1218	.01	.03	.08	.14	.25	.4	.7	.9	1.0	1.3
HM1218	.02	.05	.15	.25	.47	.7	1.1	1.5	1.8	2.2
M1221	.02	.05	.11	.20	.40	.5	.9	1.2	1.4	1.7
HM1221	.04	.10	.20	.33	.70	1.0	1.6	2.1	2.5	3.0
M1224	.03	.07	.15	.25	.50	.7	1.2	1.5	1.7	2.0
HM1224	.05	.12	.25	.47	.90	1.2	2.1	2.6	3.0	3.5
M1230	.05	.12	.25	.44	.80	1.1	1.8	2.2	2.5	3.0
HM1230	.09	.21	.40	.75	1.40	1.9	3.2	4.0	4.4	5.3
M1414	.01	.02	.02	.05	.09	.1	.2	.3	.4	.5
HM1414	.02	.04	.04	.09	.16	.2	.4	.6	.7	.9
M1616	.01	.02	.02	.05	.09	.1	.2	.3	.4	.5
HM1616	.02	.04	.04	.09	.16	.2	.4	.6	.7	.9
M1620	.02	.04	.04	.08	.14	.2	.4	.5	.6	.8
HM1620	.04	.07	.15	.25	.4	.7	.9	1.0	1.0	1.3
M1624	.03	.06	.12	.20	.3	.5	.7	.8	.8	1.0
HM1624	.05	.10	.21	.40	.5	.9	1.2	1.4	1.4	1.8
M2020	.01	.02	.04	.08	.1	.2	.2	.4	.4	.5
HM2020	.02	.04	.07	.14	.2	.4	.5	.6	.6	.8
M2025	.02	.03	.06	.12	.2	.3	.4	.5	.5	.6
HM2025	.04	.05	.10	.21	.21	.3	.5	.7	.9	1.0

Ratings listed to right of dark line exceed recommended pitch line velocity.

## HELICAL GEARS

### HELICAL GEARS

*Martin's* helical gears are cylindrical in form with teeth of 14-1/2° pressure angle cut across the face on a 45° angle. These are transverse pitch Helical gears. *Martin* does not manufacture transverse pitch, *Martin* manufactures normal diametral pitch helical gears

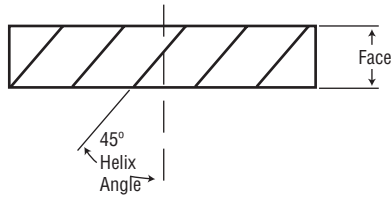

usually, with helix angles less than 25°.

They should all have hardened teeth with soft reworkable centers with the exception of a few of the smaller sizes in the lighter pitches, which are hardened all over and are indicated in the catalog. Bores and keyways should be cut before the heat treating processes.

*Martin's* helical gears are produced with teeth cut either right or left hand on any helix angle from normal diametral pitch. This makes it possible for them to operate on parallel shafts or on non-intersecting, right angle (90°) shafts. Helical gears may be cut

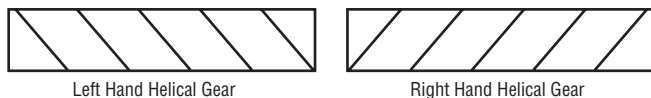

with almost any helix angle, in 14-1/2° and 20° pressure angles.

When used on parallel shafts one gear must be left hand and the other must be right hand. The normal diametral pitch, Helix angle and pressure angle must be the same for gears to mesh properly.

When used on right angle, non-intersecting shafts must be of the same hand and cut with 45° helix angles.

When helical gears are used to connect two or more parallel shafts they will run more smoothly and quietly, and are more effective than spurs at

high speeds. They may also be operated in a speed range considerably higher than spurs. For most practical installations, use at least 12 teeth for smooth action and a maximum velocity of 2000 fpm for helical gear drives. For spur gears, use a velocity of 1200 fpm as maximum. A good rule of thumb is on 14-1/2 degree use at least 15 teeth for a pinion and for 20 degree use 13T minimum.

Helical gears used to connect parallel shafts have several other inherent advantages over spur gears. The action is distributed over more than one tooth. All phases of tooth engagement, such as sliding and rolling contact, occur simultaneously which tends to equalize wear and preserve the correct tooth shape. The load is transferred gradually and uniformly as successive teeth come into engagement. The bending action resulting from tooth load is less than for a spur gear, due to the line of contact extending diagonally across the meshing teeth.

Since helical gears can have a 45° helix angle, they may be used for connecting two non-intersecting shafts that are at a 90° angle. The advantage they offer when mounted in this position is transmittal of relatively light loads at a low ratio of reduction (usually 4:1 or less). When higher ratios are desired it is more practical to use worms and worm gears.

The greatest disadvantage in the use of helicals for either type shaft connection is the end thrust developed under load due to the helix angle of the teeth.

The following pages contain diagrams illustrating the direction of thrust, in relation to shaft rotations, for all type mountings. Also indicated is the point at which adequate thrust bearings should be installed on the shafts.

In calculating thrust loads of helicals the formula used is:

$$\text{Thrust Load} = \text{Tangential Load at Pitch Line} \times \text{Tangent of Helix Angle.}$$

Since the tangent of 45° is 1.0, and helical gears have a 45° helix angle, the thrust load in all cases is

### PARALLEL SHAFTS

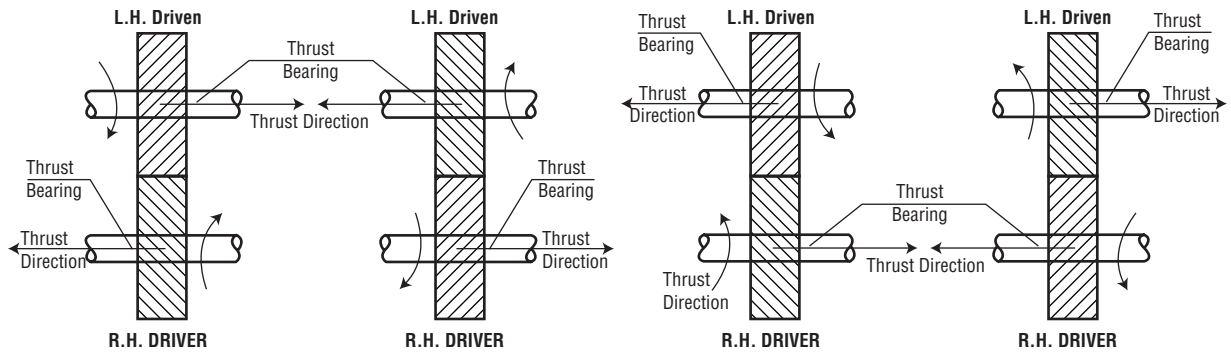

### 90° Non-Intersecting Shafts

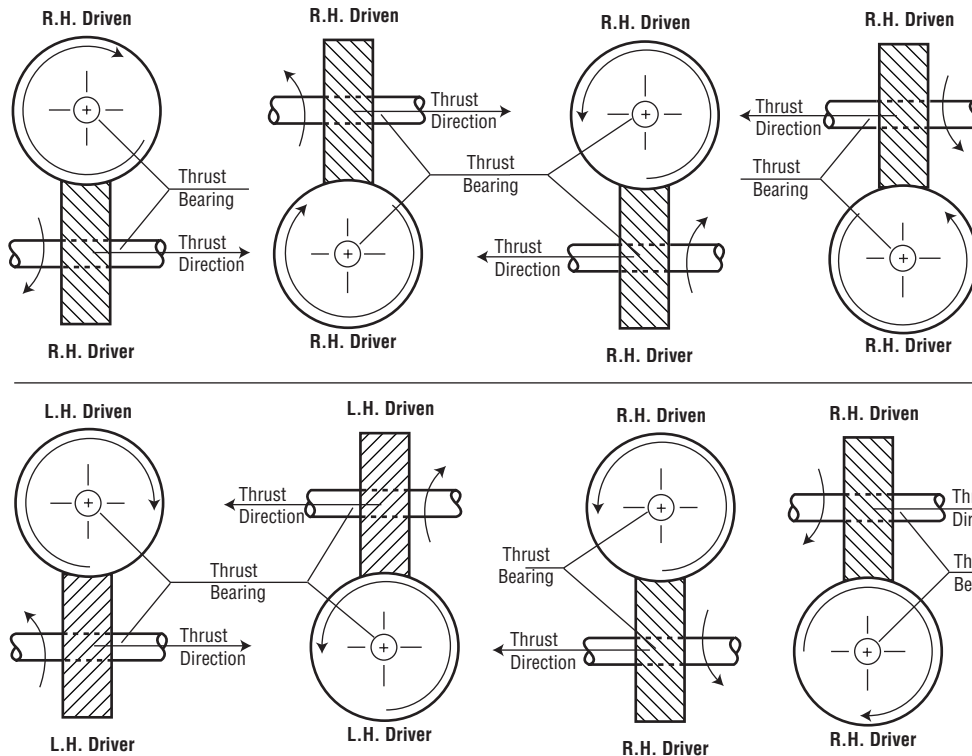

equal to the tooth load at the pitch line. In normal diametral pitch helicals, the helix angle may be varied to fit a required center distance.

### PITCH

A helical gear, like a spur gear, has both a circular and diametral pitch, which is termed transverse pitch. In addition, and unlike a spur gear, it has a circular and diametral pitch termed normal pitch.

The illustration (right) shows the transverse circular pitch which corresponds to the circular pitch of a spur gear of the same number of teeth and pitch

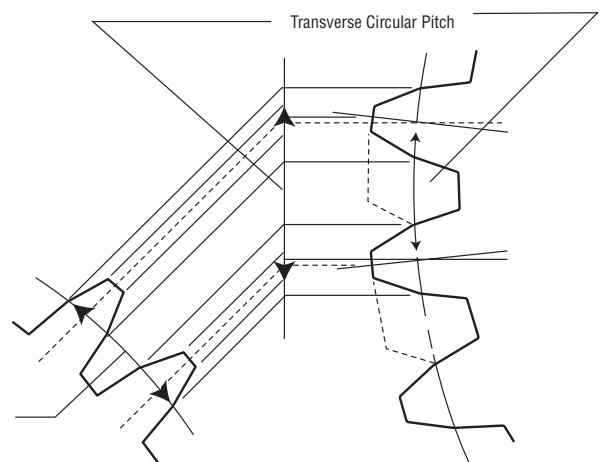

# HELICAL GEARS

diameter. The same method then will apply for determining diametral pitch.

$$\text{Transverse D.P.} = \frac{Nt}{P.D.}$$

OR

$$\text{Transverse D.P.} = \frac{\pi}{\text{Transverse C.P.}}$$

The illustration also shows the normal circular pitch as being measured in a plane perpendicular to

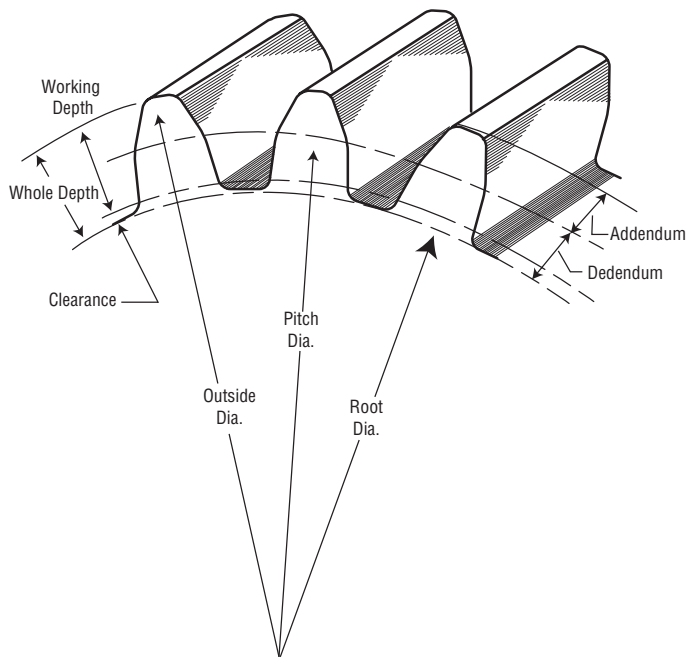

the direction of the teeth. (It is also the pitch of the cutter or hob used in cutting the teeth)

The Normal Pitch is used in calculating helical gear tooth proportions.

$$\text{Addendum} = \frac{1}{N.D.P.}$$

$$\text{Normal D.P.} = \frac{\pi}{\text{Normal C.P.}}$$

$$\text{Whole Depth} = \frac{2.157}{N.D.P.}$$

$$= \text{Addendum} + \text{Dedendum}$$

$$= \frac{\text{Outside Dia.} - \text{Root Dia.}}{2}$$

$$\text{Working Depth} = 2 \times \text{Addendum} = \text{Whole Depth}$$

- Clearance

$$\text{Clearance} = \text{Whole Depth} - 2 \text{ Addendums}$$

$$\text{Dedendum} = \text{Addendum} + \text{Clearance} = \frac{\text{Pitch Dia.} - \text{Root Dia.}}{2}$$

$$\text{Outside Diameter} = \frac{(\text{No. of Teeth} \times \text{Secant of Helix Angle}) + 2}{\text{Normal Diametral Pitch}}$$

$$\text{Outside Diameter} = \text{Pitch Diameter} + \frac{2}{\text{Normal Diametral Pitch}}$$

$$\text{Helix Angle} = \text{Cos Angle} = \frac{\text{No. of Teeth}}{\text{Normal D.P.} \times \text{Pitch Diameter}}$$

(For parallel shaft drive)

$$\text{Normal D.P.} = \frac{\text{Number of Teeth}}{\text{Pitch Dia.} \times \text{Cos Angle}}$$

$$\text{Center Distance} = \frac{P.D. \text{ dr} + P.D. \text{ dn}}{2}$$

$$\text{Helix Angle} = \text{Cos Helix Angle} = \frac{Nt}{N.S.P. \times P.D.}$$

$$\text{End Thrust} = \text{Load} \times \text{Tan Helix Angle}$$

$$\text{Helix Angel (to Figure Center Distance)} = \frac{\text{Cos Helix Angle} = Nt + nt}{2X \text{ C.D.} \times N.D.P.}$$

The Transverse Pitch can be used in determining the pitch diameter of a helical gear and the formula is:

$$P.D. = \frac{Nt}{T.D.P.}$$

OR

$$P.D. = \frac{Nt}{N.D.P. \times \text{Cos Helix Angle}}$$

In all other calculations of helical gear dimensions the NORMAL PITCH is used and the formulas are as follows:

$$\text{Whole Depth} = \frac{2.157}{\text{N.D.P.}}$$

$$\text{Addendum} = \frac{1}{\text{N.D.P.}}$$

$$\text{Clearance} = \text{Whole Depth} - 2 \times \text{Addendum}$$

$$\text{Outside Diameter} = \text{Pitch Diameter} + 2 \text{ Addendums}$$

### EXAMPLES

What are the following dimensions of a 6 transverse diametral pitch helical gear having 24 teeth?

Whole Depth - Addendum - Clearance - Outside Diameter

$$1. \text{ WD} = \frac{2.157}{\text{N.D.P.}} = \frac{2.157}{8.48} = .2543$$

$$2. \text{ A} = \frac{1}{\text{N.D.P.}} = \frac{1}{8.48} = .1179$$

$$3. \text{ C} = \text{WD} - (2\text{A}) = .2543 - (2 \times .1179) = .2543 - .2358 = .0185$$

$$4. \text{ OD} = \text{PD} + (2\text{A}) = 4 + (2 \times .1179) = 4.2358$$

$$\text{PD} = \frac{\text{N}}{\text{T.D.P.}} = \frac{24}{6} = 4$$

### APPROXIMATE RATINGS OF HORSE-POWER TRANSVERSE D.P. HELICAL GEARS ON PARALLEL SHAFTS

*NOTE: When using on right angle shaft mounting use one third of the table rating.*

#### 24 DP 1/4 FACE

	Revolutions Per Minute									
	50	100	200	300	400	600	900	1200	1800	
H2408	.01	.02	.03	.04	.06	.08	.12	.16	.20	
H2412	.01	.03	.05	.07	.10	.13	.18	.24	.31	
H2418	.02	.04	.07	.10	.14	.19	.26	.32	.43	
H2424	.03	.05	.10	.14	.19	.25	.34	.41	.53	
H2436	.04	.08	.14	.20	.25	.35	.46	.54	.67	
H2440	.04	.09	.15	.22	.28	.38	.49	.57	.70	
H2448	.05	.10	.18	.26	.31	.43	.55	.63	.76	

#### 20 DP 3/8 FACE

	Revolutions Per Minute									
	50	100	200	300	400	600	900	1200	1800	
H2008	.02	.03	.07	.10	.13	.19	.28	.35	.46	
H2010	.02	.04	.08	.12	.16	.22	.32	.40	.55	
H2020	.05	.09	.17	.25	.32	.44	.60	.73	.93	
H2025	.06	.11	.21	.30	.38	.53	.71	.85	1.06	
H2030	.07	.14	.25	.36	.45	.61	.81	.96	1.19	
H2035	.08	.16	.28	.41	.51	.68	.89	1.05	1.28	
J2040	.09	.18	.33	.46	.58	.77	.98	1.15	1.36	
H2060	.14	.26	.47	.64	.78	1.00	1.22			

#### 16 DP 1/2 FACE

	Revolutions Per Minute									
	50	100	200	300	400	600	900	1200	1800	
H1608	.03	.05	.12	.18	.25	.35	.50	.63	.85	
H1612	.05	.10	.20	.30	.35	.54	.76	.95	1.22	
H1616	.08	.15	.28	.40	.52	.72	.86	1.19	1.52	
H1620	.10	.18	.35	.49	.63	.85	1.14	1.36	1.70	
H1624	.13	.22	.40	.58	.73	1.00	1.30	1.53	1.88	
H1632	.16	.30	.53	.75	.94	1.25	1.62	1.87	2.22	
H1640	.21	.37	.65	.90	1.11	1.44	1.84	2.12		
H1648	.25	.44	.76	1.05	1.27	1.64	2.06	2.38		

#### 12 DP 3/4 FACE

	Revolutions Per Minute									
	50	100	200	300	400	600	900	1200	1800	
H1210	.12	.26	.48	.70	.88	1.20	1.64	2.00	2.58	
H1212	.17	.31	.51	.78	1.00	1.39	1.89	2.52	2.90	
H1215	.22	.38	.68	.97	1.21	1.69	2.28	2.70	3.28	
H1218	.27	.46	.80	1.15	1.43	1.96	2.57	3.08	3.75	
H1221	.30	.50	.90	1.28	1.60	2.18	2.90	3.38	4.08	
H1224	.35	.59	1.08	1.47	1.83	2.48	3.18	3.72	4.40	
H1230	.40	.72	1.25	1.75	2.09	2.84	3.60	4.15		
H1236	.50	.86	1.52	2.10	2.54	3.25	4.00	4.52		
H1248	.70	1.51	1.90	2.55	3.12	4.02	4.80			

#### 10 DP 7/8 FACE

## HELICAL GEARS

	Revolutions Per Minute								
	50	100	200	300	400	600	900	1200	1800
H1010	.20	.38	.71	1.03	1.34	1.86	2.52	3.08	3.90
H1015	.30	.60	1.10	1.55	1.94	2.70	3.54	4.20	5.15
H1020	.44	.82	1.50	2.10	2.60	3.54	4.48	5.20	6.00
H1025	.58	.95	1.78	2.46	3.00	3.96	4.96	5.68	6.50
H1030	.70	1.20	2.14	2.90	3.50	4.50	5.54	6.30	
H1040	.85	1.40	2.70	3.60	4.20	5.35	6.40		

### 8 DP 1 FACE

	Revolutions Per Minute								
	50	100	200	300	400	600	900	1200	1800
H810	.25	.55	.98	1.37	1.75	2.48	3.40	4.18	4.80
H812	.32	.60	1.13	1.60	2.05	2.80	3.82	4.60	5.38
H816	.48	.85	1.55	2.13	2.63	3.55	4.60	5.35	6.30
H820	.60	1.03	1.83	2.50	3.13	4.10	5.40	5.90	
H832	.90	1.65	2.80	3.80	4.50	5.63	6.70		
H36	1.01	1.80	3.05	4.10	4.85	5.90	7.13		
H480	1.20	1.95	3.30	4.38	5.14	6.35	7.50		

### 6 DP 1-1/4 FACE

	Revolutions Per Minute								
	50	100	200	300	400	600	900	1200	1800
H609	.56	.86	1.90	2.91	3.38	4.50	5.78	6.68	8.06
H612	.75	1.15	2.50	3.60	4.50	6.00	7.70	8.90	10.75
H615	.90	1.80	3.25	4.35	5.50	7.15	8.80	10.20	
H618	1.20	2.15	3.85	5.25	6.40	8.10	10.00	11.30	
H624	1.55	2.85	4.80	6.50	7.85	9.80	11.65		
H630	1.85	3.35	5.75	7.50	8.90	10.90			
H636	2.13	4.10	6.80	8.65	10.00	12.00			

### GEAR TOOTH WEAR AND FAILURE

The sliding and meshing of gear teeth under load causes gear failure due to wear. Gear manufacturers design certain parts of a gear train to wear out or break sooner than others. This is done because some gears are physically easier to replace than others or one gear may be cheaper than another in a set. The following examples apply only to metallic gears, the teeth of which have been produced by one or more machining operations such as: cutting, shaving, lapping, and grinding.

#### SURFACE DETERIORATION

Wear is a general term to cover the sliding of metal against metal, or abrasion by lapping or scratching.

**Normal Wear** is the loss of metal from the surface of a gear tooth which results from unavoidable abrasion at such a rate, and to such a degree, which will not prevent the gear from performing satisfactorily during its expected life.

**Abrasive Wear** is surface injury caused by fine, or fairly fine particles carried in the lubricant or embedded in tooth surfaces. These particles may be metal that detaches from the gear teeth or bearings, abrasive not completely removed before assembling, sand or scale from castings, or other impurities in the oil or in the surrounding atmosphere.

Abrasive material may enter a gear housing due to a harsh environment or may have been left in the gear housing as residual casting scale when the component was manufactured. Abrasive wear corrective action includes:

- Drain and flush residual oil.
- Clean out and flush any oil passages.
- Refill the housing with a light flushing grade oil and run without load for approximately 10 minutes.
- Clean breathers and replace seals and filters if suspected contamination was from the environment.
- Drain the flushing oil and refill with correct oil.

**Scratching** is a form of wear characterized by

deep scratches in the direction of surface sliding. It is caused by particles that are larger in size than those associated with abrasive wear.

**Overload Wear** is a form of wear experienced under conditions of heavy load and low speed in both hardened and unhardened gears. Metal seems to be removed progressively in thin layers or flakes, leaving surfaces that appear somewhat as if etched.

**Ridging** is a particular form of scratching that may occur on case-hardened surfaces of hypoid pinions under heavy load. It would appear as closely spaced grooves and ridges in the direction of surface sliding.

**Plastic Yielding** is a deformation of tooth surfaces resulting from heavy loads and characterized by fins on the tip edges (or ends) of the teeth (not to be confused with shaving fins), and by an occasional ridge and matching groove on the mate at the pitch lines. It is usually associated with ductile materials but occurs with hardened steel as well.

**Rolling & Scuffing** is a form of plastic yielding resulting from heavy, even loads and sliding.

Improper adjustments include radial/axial misalignment, improper end play, out of tolerance backlash, and manufacturer's defect. In gear teeth that do not mesh correctly due to misalignment, the gear wears at high points and removes metal until a mating profile is established. In cases such as manufacturer's defect, once a mating profile has been established, wear lightens or ceases. However, all other misalignment, if not corrected, continue to wear to gear destruction.

**Peening** is a form of plastic yielding caused by localized impacts or by uneven heavy or shock loads.

**Rippling** is a form of plastic yielding over areas of case-hardened steel surfaces under heavy sliding load and is characterized by a fish-scale pattern.

**Welding** is a general kind of surface deterioration which occurs when pressure, sliding and rise of temperature combine to cause the lubrication film to be forced out, thereby allowing metallic surfaces to rub directly against each other to the extent that molecu-

## GEAR TOOTH WEAR AND FAILURE

lar adhesion, or welding occurs followed by immediate tearing apart. Welding can frequently be avoided or arrested by the use of a suitable extreme pressure lubricant.

**Slight Scoring** is a minor impairment of the surface of a welding nature which show slight tears and scratches in the direction of sliding. The scoring will start in an area having a high combination of surface stress and sliding velocity and generally occurs at or near the tip of the tooth. (The term “scoring” has been selected in this nomenclature, in preference to scuffing, seizing, galling, roping, etc.)

**Severe Scoring** is a more advanced degree of welding which shows deep scratches and adhesion, and leads to rapid deterioration.

**Surface Fatigue** is the formation of cavities in the surface of the teeth, usually quite small at first, and at separated areas of high compressive stress. It often results from surface irregularities.

**Initial Pitting** may occur when a pair of gears is first started in service, and may continue only to the stage when local high spots have been reduced so as to provide sufficient area of contact to carry the load without further impairment. This type of pitting is generally not necessarily serious because it tends to be corrective and non-progressive.

**Destructive Pitting** is the type that continues to progress after the initial period of operation, often at an increasing rate and to the degree that remaining unpitted areas are insufficient to carry the load.

Continued operation may produce rapid destruction.

**Electrical Pitting** is an electric arc discharge across the film of oil between mating gear teeth. The temperatures produced are high enough to locally melt gear tooth surfaces. Damage from electrical pitting may be caused by improperly grounded electrical connections, high static charges, or improper welding connections. Electrical pitting is identified by many small craters surrounded by burned or fused metal.

Electric current on gears may break down lubricant if the current is not high enough to etch metal but is high enough to locally burn and break down lubricants. Electrical pitting corrective action includes:

- Placing a ground clamp on the same side of a gear box when welding.
- Running grounding straps from a machine to rigid electrical or pneumatic piping to reduce



*Normal Wear*



*Abrasive Wear.*



*Scratching*



*Overload Wear*

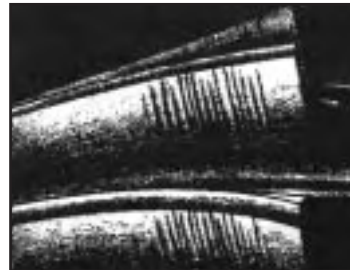

*Ridging*



*Rolling and Peening*



*Rippling*



*Slight Scoring*



*Severe Scoring*



*Initial Pitting*

static electricity created by manufacturing processes.

- Check the electrical system for proper installation and grounding.

**Spalling** is a more extensive type of surface fatigue in which a considerable area of surface is progressively undermined and eventually breaks out in small or large flakes. This seems to occur only in case-hardened gears. Spalling may start at a crack in a way similar to pitting, and does not necessarily follow the junction between case and core.

**Corrosive Wear** is the result of chemical action on metal tooth surfaces produced by improper kinds of lubricants (either by acid or alkaline contamination or by oxidation). The effect may be accelerated by excessive moisture in gear cases.

Corrosion attacks the entire gear, but wear is greatest on working surfaces because the build-up of corrosion itself becomes a partial insulator to the non-working surfaces. Corrosive wear corrective action includes:

- Reducing the load if the system is overloaded.
- Upgrading the system if the system is overloaded and the load cannot be reduced.
- Using an extreme-pressure lubricant if a system is overloaded and the load cannot be reduced nor the system upgraded.
- Checking to see if the wrong grade of lubricant is being used. Contact the machine manufacturer or an oil company representative for proper lubricant specifications.
- Checking the frequency of oil changes. It may be necessary to increase the oil change frequency.

**Burning** produces discoloration and loss of hardness, and results from high temperatures produced by excessive friction, overload, overspeed, lack of backlash, or faulty lubrication.

**Interference** is a type of failure due to extremely heavy tooth contact in a limited area. It is caused by improper tooth action, such as excessive heavy contact between the tip edge of one tooth and the fillet surface of mating tooth which results in localized abrasion or gouging. Such a condition may be the result of improper gear design or manufacture, or faulty assembly of the gears at too close a center

distance for their profile shapes.

**Grinding Checks** are fine cracks in a definite pattern which may be caused by improper grinding technique, or improper heat treatment, or both. They are usually not visible until the gears are placed in



*Destructive Pitting*



*Spalling*

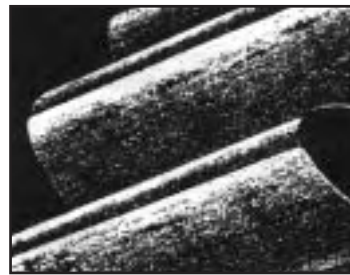

*Corrosive Wear*

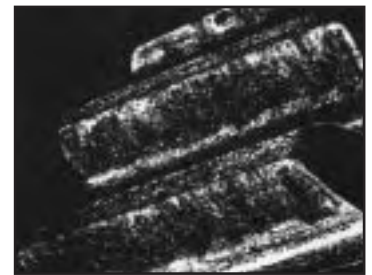

*Burning*



*Interference*

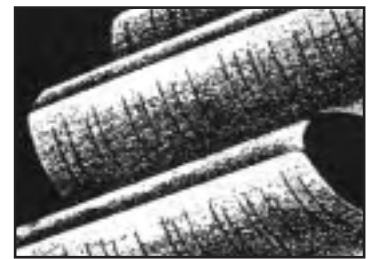

*Grinding Checks*



*Overload Breakage*



*Fatigue Breakage*



*Cracking*



*Quenching Cracks*

## GEAR TOOTH WEAR AND FAILURE

---

service.

Fatigue Wear is gear wear created by repeated stresses below the tensile strength of the material. Fatigue may be identified as cracks or fractures. A fatigue crack is a crack in a gear that occurs due to bending, mechanical stress, thermal stress, or material flaws. A fatigue fracture is a breaking or tearing of gear teeth. Fatigue cracks usually culminate in a fracture when the fatigue crack grows to a point where the remaining tooth section can no longer support the load. Fatigue wear begins at the first moment a gear is used. Fatigue wear is repeated minute deformations under normal stress (normally unseen and immeasurable) that eventually produce cracks or fractures.

Sufficient alternating stresses (vibrations) produce rapid fatigue fracture in industrial gear trains. Other destructive noises, vibrations, overloading, and grinding of gears and gear surfaces must be identified early to be effectively corrected. Proper installation procedures, effective lubrication techniques, and regular periodic inspections with service can produce a successful, profit-oriented mechanical installation.

### TOOTH BREAKAGE

**Overload Breakage** refers to gear tooth breakage resulting from an unexpected shock overload such as jamming of the machinery. It is generally not attributable to improper design, application, or faulty manufacture of the gears.

**Fatigue Breakage** results from the gear material crystallizing through a large number of repetitions of the load (revolutions or cycles), and not from a single application of a shock load. A fatigue break is of a progressive nature that starts as a short crack which continues to extend until a portion, or a whole tooth breaks loose. Discoloration and apparent rubbing on the fractured surfaces are indications of fatigue breakage. Sometimes fatigue fractures are characterized by a series of “contour” lines roughly concentric and spreading from a focal point. This area has a smoother appearance than the surface of the final fracture.

**Cracking** results from residual stresses induced in hardenable material by faulty manufacturing control,

or from improper operating conditions. One cause is too soft a core, or some other form of improper heat treatment. Chipping and flaking represent various forms or degrees of cracking failures in which portions of teeth break out.

Quenching Cracks result from improper heat treatment, or from extremely sharp fillets or tool marks. They usually start at the roots or ends of the teeth. Deliberate fracturing of such a tooth will show a dark area where the crack existed.

Assessing and evaluating gear tooth wear is important in determining causes for excess wear. Often wear can be detected in the preliminary stages, the trouble corrected, and many hours of life added to the gears. Careful and periodic inspection of gears, particularly in connection with large gear drive units, is an important part of proper gear maintenance.

**Addendum:** the height of the tooth above the pitch circle.

**Angular Pitch:** The angle subtended by the circular pitch, usually expressed in radians.

**Axial Base Pitch:** The base pitch of helical involute tooth surfaces in an axial plane.

**Axial Pitch:** Linear pitch in an axial plane and in a pitch surface. In helical gears and worms, axial pitch has the same value at all diameters. In gearing of other types, axial pitch may be confined to the pitch surface and may be in a circular measurement.

**Backlash:** The play between mating teeth or the shortest distance between the non-driving surfaces of adjacent teeth.

**Base Pitch:** In an involute gear, the pitch on the base circle or along the line of action.

Corresponding sides of involute gear teeth are parallel curves, and the base pitch is the constant and fundamental distance between them along a common normal in a plane of rotation.

**Bevel Gears:** Gears with teeth on the outside of a conical-shaped body (normally used on 90-degree axes.)

**Bottom Land:** The surface at the bottom of the space between adjacent teeth.

**Center Distance:** The distance between non-intersecting axes of mating gears.

**Chordal Thickness:** Also called "tooth thickness". The thickness of a tooth at the pitch circle when measuring with a gear tooth caliper.

**Circular Pitch:** The length of the arc of the pitch circle between the centers of other corresponding points of adjacent teeth.  $CIRCULAR\ PITCH = 3.1416/DIAMETRAL\ PITCH$ .

**Circular Thickness:** The thickness of the tooth measured on the pitch circle.

**Clearance:** The radial distance between the top of one tooth and the bottom of the mating tooth space.

**Contact Ratio:** To assure smooth, continuous tooth action, as one pair of teeth passes out of action, a succeeding pair of teeth must have already started action. It is desired to have as much overlap as possible. A measure of this overlapping action is the contact ratio.

**Crown:** A modification that results in the flank of each gear tooth having a slight outward bulge in its center area. A crowned tooth becomes gradually

thinner toward each end. A fully crowned tooth has a little extra material removed at the tip and root areas also. The purpose of crowning is to ensure that the center of the flank carries its full share of the load even if the gears are slightly misaligned or deflect under load.

**Dedendum:** The depth of the tooth space below the pitch circle.

**Diametral Pitch:** The ratio of the number of teeth to the number of inches of pitch diameter.  $DIAMETRAL\ PITCH = 3.1416 / CIRCULAR\ PITCH$ .

**External Gears.** Gears with teeth on the outside of a cylinder.

**Face of Tooth:** The surface between the pitch circle and the top of tooth.

**Face Gears:** Gears with teeth on the end of the cylinder.

**Face Width:** The tooth length in an axial plane.

**Flank of Tooth:** The surface between the pitch circle and the bottom of the tooth space.

**Flank:** The working, or contacting, side of the gear tooth. The flank of a spur gear usually has an involute profile in a transverse section.

**Flash Temperature:** The temperature at which a gear tooth surface is calculated to be hot enough to destroy the oil film and allow instantaneous welding or scoring at the contact point.

**Full Depth Teeth:** Those in which the working depth equals 2.000 divided by normal diametral pitch.

**Gear Center:** The center of the pitch circle.

**Gear Ratio:** The ratio of the number of teeth in mating gears. Usually the number of teeth in the gear divided by the number of teeth in the pinion.

**Gear-Tooth Ratio:** The ratio of the larger to the smaller number of teeth in a pair of gears.

**Helix Angle:** The inclination of the tooth in a lengthwise direction. If the helix angle is 0 degrees, the tooth is parallel to the axis of the gear and is really a spur-gear tooth.

**Helical Gears:** Gears with teeth that spiral around the body of the gear.

**Hypoid Gears:** Similar in general form to bevel gears, but operate on non-intersecting axes.

## GLOSSARY

**Hunting Ratio:** A ratio of numbers of gear and pinion teeth which ensures that each tooth in the pinion will contact every tooth in the gear before it contacts any gear tooth a second time (13 to 48 is a hunting ratio; 12 to 48 is not a hunting ratio.)

**Internal Gears:** Gears with teeth on the inside of a hollow cylinder. (The mating gear for an internal gear must be an external gear.)

**Lead:** The axial advance of a thread or a helical spiral in 360 degree (One turn about the shaft axis).

**Lead Angle:** The inclination of a thread at the pitch line from a line 90 degrees to the shaft axis.

**Line of Action:** The path of action for involute gears. It is the straight line passing through the pitch point and tangent to each other.

**Line of Centers:** Connects the centers of the pitch circles of two engaging gears; it is also the common perpendicular of the axes in crossed helical gears and worm gears.

**Offset:** The perpendicular distance between the axes of hypoid gears or offset face gears.

**Outside Diameter:** (External gears) The distance from the top of one tooth to the top of a tooth opposite measured through the axis of the gear.  $OUTSIDE\ DIAMETER = NUMBER\ OF\ TEETH + 2 / DIAMETRAL\ PITCH.$

**Pitch:** The distance between similar, equally spaced tooth surfaces along a given line or curve.

**Pitch Angle:** In bevel gears, the angle between an element of a pitch cone and its axis.

**Pitch Circle:** The circle through the pitch point having its center at the axis of the gear. Pitch circles are tangent in mating gears.

**Pitch Diameter:** The diameter of the pitch circle.  $PITCH\ DIAMETER = NUMBER\ OF\ TEETH / DIAMETRAL\ PITCH.$

**Pitch Point:** The point of a gear-tooth profile which lies on the pitch circle of that gear. At the moment that the pitch point of one gear contacts its mating gear, the contact occurs at the pitch point of the mating gear, and this common pitch point lies on a line connecting the two gear centers.

**Point of Contact:** Any point at which two tooth profiles touch each other.

**Pressure Angle:** The angle between a tangent to the tooth profile and a line perpendicular to the pitch surface. Standard gears are either 14-1/2 degree or

20 degree. All mating gears must be of the same pressure angle.

**Root Circle:** Tangent to the bottom of the tooth spaces in a cross section.

**Root Diameter:** The distance from the bottom of one tooth to the bottom of a tooth opposite measured through the axis of the gear.

**Runout:** A measure of eccentricity relative to the axis of rotation. Runout is measured in a radial direction and the amount is the difference between the highest and lowest reading in 360 degrees, or one turn. For gear teeth, runout is usually checked by either putting pins between the teeth or using a master gear. Cylindrical surfaces are checked for runout by a measuring probe that reads in a radial direction as the part is turned on its specified axis.

**Tooth Surface:** The side of a gear tooth, or the total area including the tooth face and the tooth flank.

**Shaft Angle:** The angle between the axes of two non-parallel gear shafts.

**Spur Gears:** Gears with teeth straight and parallel to the axis of rotation.

**Tip Relief:** A modification of a tooth profile, whereby a small amount of material is removed near the tip of the gear tooth to accommodate smooth engagement of the teeth.

**Tooth surface:** Forms the side of a gear tooth.

**Tooth profile:** One side of a tooth in a cross section between the outside circle and the root circle.

**Top Land:** The top surface of a gear tooth.

**Undercut:** When part of the involute profile of a gear tooth is cut away near its base, the tooth is said to be undercut. Undercutting becomes a problem when the number of pinion teeth is small.

**Whole Depth:** The radial distance between the outside diameter and the root diameter. It is also known as "Tooth Depth," and equals the sums of the addendum and the dedendum.

**Working Depth:** The depth to which a tooth extends into the tooth space of a mating gear when the center distance is standard. It is equal to the sums of the operating addendums of the two teeth.

**Worm Gears:** Gearsets in which one member of the pair has teeth wrapped around a cylindrical body like screw threads. (Normally this gear, called the worm, has its axis at 90 degrees to the worm-gear axis.)

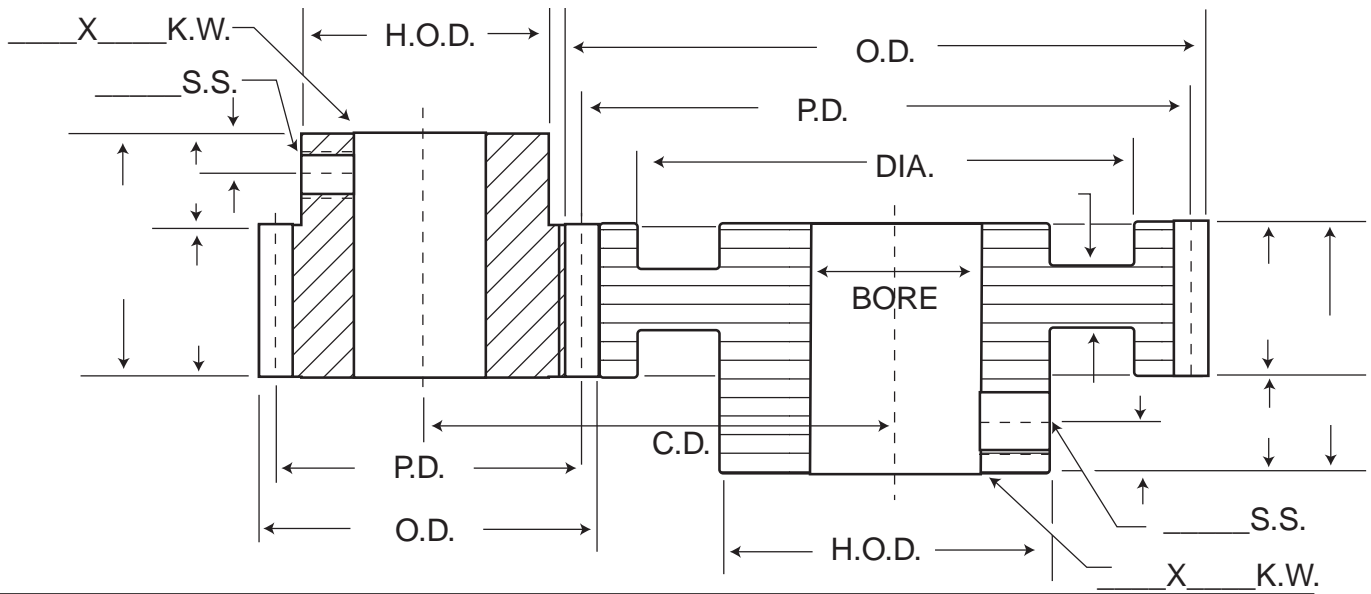

### SPECIFICATIONS

	Pinion	Rack
Diametral Pitch		
Pressure Angle		
Pin Size Over ( ) Pin Diameter		
Number of Teeth		
Material Specifications		
Heat Treatment		
R.P.M. of Gears		
Torque		
Horsepower Transmitted		
Lubrication		
Horsepower Transmitted		
Lubrication		

Duty Cycle:

Service Characteristics:

Remarks:

Customer: \_\_\_\_\_ Phone: \_\_\_\_\_

Address: \_\_\_\_\_ Date: \_\_\_\_\_

Individual Contacted: \_\_\_\_\_ Salesperson: \_\_\_\_\_

# RACK GEAR DATA SHEET

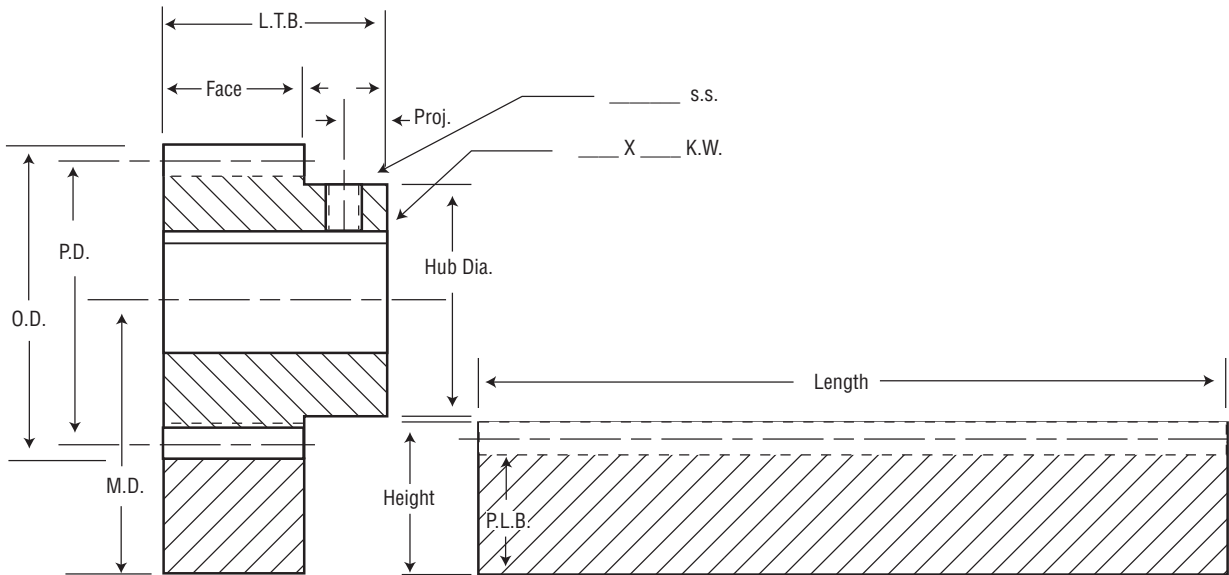

## SPECIFICATIONS

	Pinion	Rack
Diametral Pitch		
Pressure Angle		
Mounting Distance with Pinion		
Pin Size Over ( ) Pin Diameter		
Length		
Face Width		
Height		
Material Specifications		
R.P.M. of Pinion or F.P.M. of Rack		
Torque		
Horsepower Transmitted		
Lubrication		

Duty Cycle:

Service Characteristics:

Remarks:

Customer: \_\_\_\_\_ Phone: \_\_\_\_\_

Address: \_\_\_\_\_ Date: \_\_\_\_\_

Individual Contacted: \_\_\_\_\_ Salesperson: \_\_\_\_\_

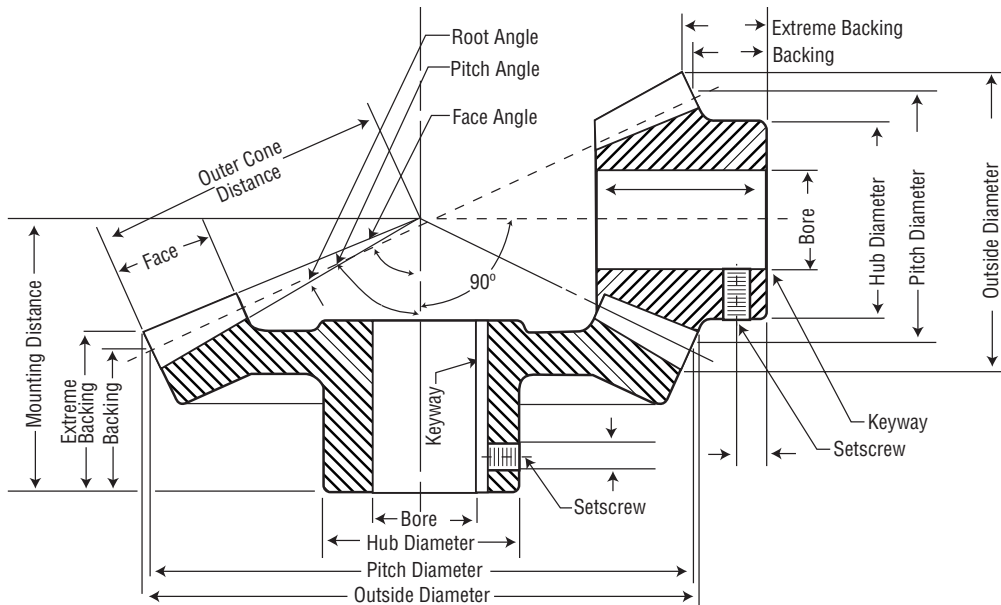

### SPECIFICATIONS

	Pinion	Rack
Diametral Pitch		
Pressure Angle		
Number of Teeth		
Face Angle		
Pitch Angle		
Root Angle		
Material		
Heat Treatment		
R.P.M.		
Torque		
Horsepower		
Lubrication		
Duty Cycle:		

Service Characteristics: (Shock, High or Low Temp., Etc.)

Remarks: (Use Reverse Side for Sketch of Application)

Customer: \_\_\_\_\_ Phone: \_\_\_\_\_

Address: \_\_\_\_\_ Date: \_\_\_\_\_

Individual Contacted: \_\_\_\_\_ Salesperson: \_\_\_\_\_

# MITER GEAR DATA SHEET

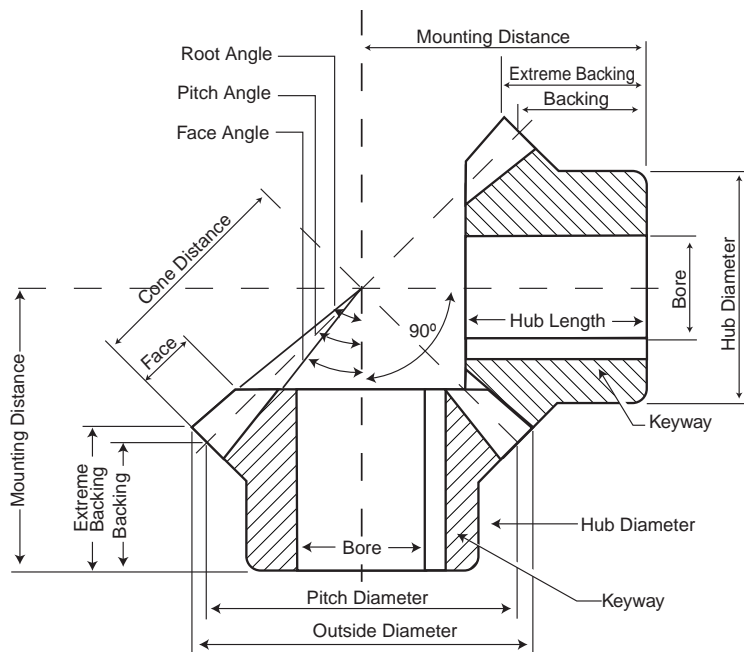

## SPECIFICATIONS

	Pinion	Rack
Diametral Pitch		
Pressure Angle		
Number of Teeth		
Face Angle		
Pitch Angle		
Root Angle		
Tooth Angle		
Material		
Heat Treatment		
R.P.M.		
Torque		
Horsepower		
Lubrication		
Duty Cycle:		

Service Characteristics: (Shock, High or Low Temp., Etc.)

Remarks: (Use Reverse Side for Sketch of Application)

Customer: \_\_\_\_\_ Phone: \_\_\_\_\_

Address: \_\_\_\_\_ Date: \_\_\_\_\_

Individual Contacted: \_\_\_\_\_ Salesperson: \_\_\_\_\_

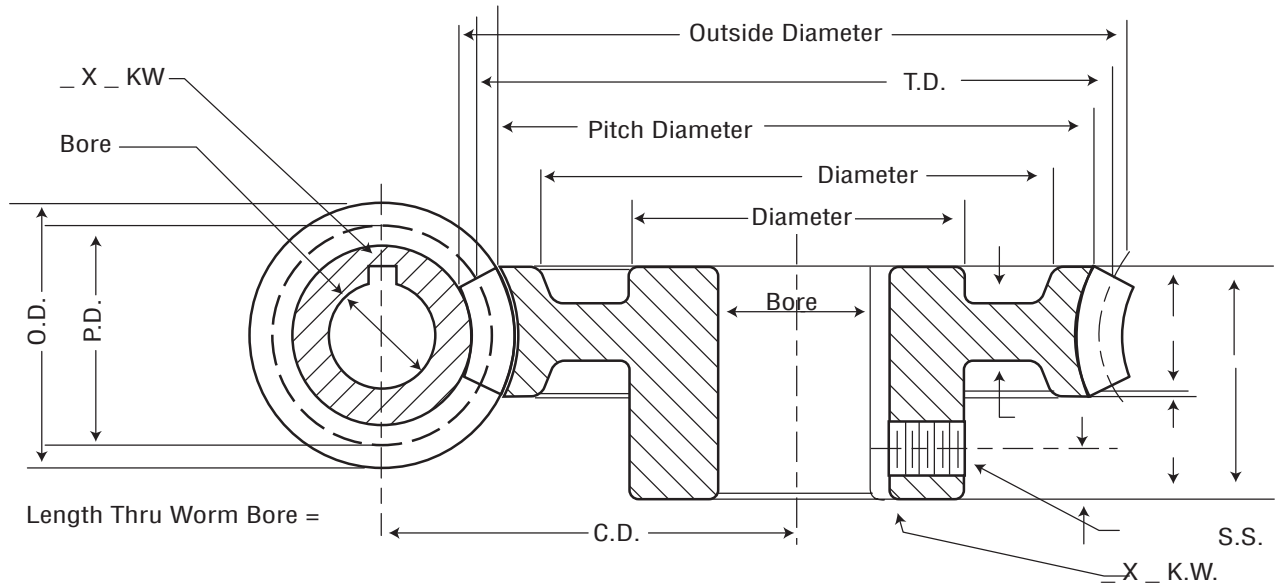

### SPECIFICATIONS

	Worm	Worm Gear
Pitch (Diametral) (Circular)		
Normal Pressure Angle		
Number of Threads ---Teeth		
Helix Angle (Right Hand) (Left Hand)		
Material		
Heat Treatment		
R.P.M.		
Torque		
Horsepower		
Lubrication		
Lead of Worm Thread ( ) is Thread to be Ground (Yes) (No)		

Duty Cycle: \_\_\_\_\_

Service Characteristics: (Shock, High or Low Temp., Etc.) \_\_\_\_\_

Remarks: (Use Reverse Side for Sketch of Application) \_\_\_\_\_

Customer: \_\_\_\_\_ Phone: \_\_\_\_\_

Address: \_\_\_\_\_ Date: \_\_\_\_\_

Individual Contacted: \_\_\_\_\_ Salesperson: \_\_\_\_\_

# HELICAL GEAR DATA SHEET

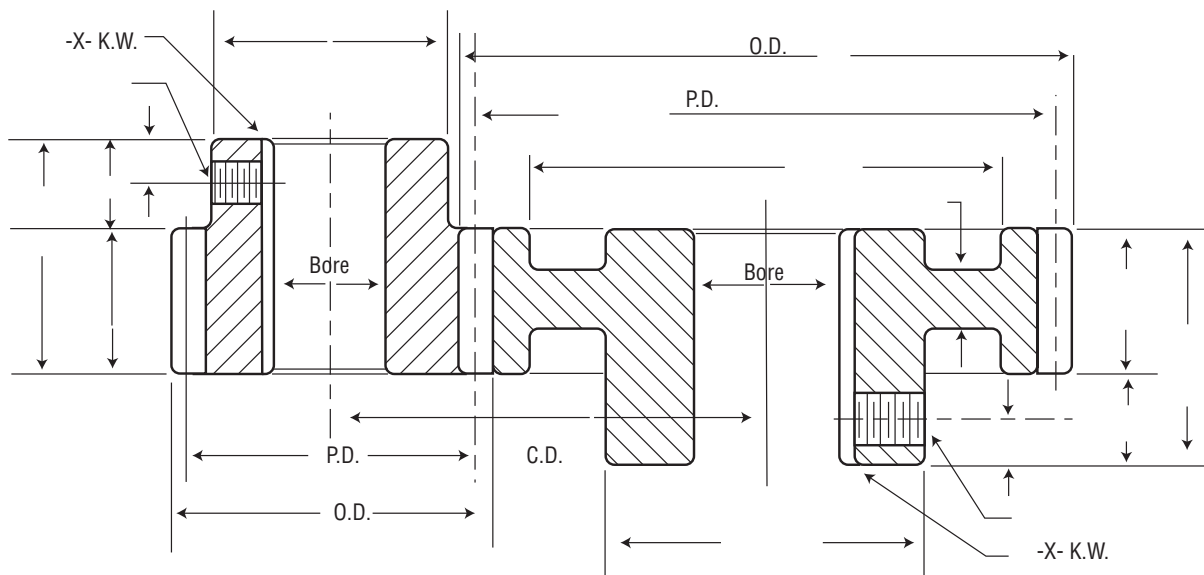

## SPECIFICATIONS

	Pinion	Gear
Diametral Pitch (Normal) (Axial)		
Pressure Angle (Normal) (Axial)		
Helix Angle (Right Hand) (Left Hand)		
Pin Size Over ( ) Pins		
Number of Teeth		
Material		
Heat Treatment		
R.P.M.		
Torque		
Horsepower		
Lubrication		

Duty Cycle:

Service Characteristics: (Shock, High or Low Temp., Etc.)

Remarks: (Use Reverse Side for Sketch of Application)

Customer: \_\_\_\_\_ Phone: \_\_\_\_\_

Address: \_\_\_\_\_ Date: \_\_\_\_\_

Individual Contacted: \_\_\_\_\_ Salesperson: \_\_\_\_\_

Abrasive Wear . . . . .	.44	First Law of Motion . . . . .	.1
Addendum . . . . .	.11, 48	Flank . . . . .	.48
American Std. . . . .	13	Flank of Tooth . . . . .	.48
American Stub . . . . .	.13	Flash Temperature . . . . .	.48
American Stub Tooth Calculations . . . . .	13	Force . . . . .	.1
Angular Pitch . . . . .	48	Full Depth Teeth . . . . .	.48
Approx. Ratings of Horsepower Transverse DP		Gear Center . . . . .	.48
Helical Gears on Parallel Shafts . . . . .	.42	Gear Drives . . . . .	.5
Axial Base Pitch . . . . .	.48	Gear Ratio . . . . .	.48
Axial Pitch . . . . .	.48	Gear Tooth Wear and Failure . . . . .	.44
Backlash . . . . .	12, 48	Gear-Tooth Ratio . . . . .	.48
Base Pitch . . . . .	.48	General Formulas . . . . .	.12
Bevel Gear Nomenclature . . . . .	33	Grinding Checks . . . . .	.46
Bevel Gears . . . . .	.8, 31, 48	Helical Gears . . . . .	7, 39, 48
Bottom Land . . . . .	.48	Helix Angle . . . . .	.48
Burning . . . . .	.45	Herringbone Gears . . . . .	7
Center Distance . . . . .	.48	Horsepower . . . . .	.2
Chordal Thickness . . . . .	.48	Horsepower & Torque Ratings . . . . .	30
Circular Pitch . . . . .	11, 48	Horsepower Ratings . . . . .	37
Circular Thickness . . . . .	.48	Hunting Ratio . . . . .	49
Clearance . . . . .	.11, 48	Hypoid Gears . . . . .	9, 49
Contact Ratio . . . . .	.48	Inclined Plane . . . . .	3
Corrosive Wear . . . . .	.45	Initial Pitting . . . . .	45
Cracking . . . . .	.46	Interference . . . . .	45
Crown . . . . .	.48	Internal Gears . . . . .	7, 49
Dedendum . . . . .	.11, 48	Introduction . . . . .	1
Definition of Radian . . . . .	4	Involute Curve . . . . .	6
Destructive Pitting . . . . .	.45	Lead . . . . .	49
Diametral Pitch . . . . .	.48	Lead Angle . . . . .	49
Efficiency . . . . .	.29	Levers . . . . .	2
Electrical Pitting . . . . .	.45	Line of Action . . . . .	49
External Gears . . . . .	.48	Line of Centers . . . . .	49
Face Gears . . . . .	.48	Mechanical Power Transmission Fundamentals . . . . .	.1
Face of Tooth . . . . .	.48	Mechanical Advantage . . . . .	2
Face Width . . . . .	.48	Miter Gears . . . . .	.8, 37
Fatigue Breakage . . . . .	.46	Mounting Distance . . . . .	32
Fellows Stub . . . . .	.13	Normal Wear . . . . .	.44
Fellows Stub Tooth . . . . .	.13	Offset . . . . .	.49

# INDEX

Outside Diameter . . . . .	49	Second Law of Motion . . . . .	.1
Overload Breakage . . . . .	46	Self - Locking . . . . .	.29
Overload Wear . . . . .	44	Severe Scoring . . . . .	.45
Parts and Nomenclature . . . . .	10	Shaft Angle . . . . .	.49
Peening . . . . .	44	Shaft Centers are not Parallel . . . . .	.8
Pitch . . . . .	10, 27, 40, 49	Six Basic Simple Machines . . . . .	.2
Pitch and Tooth Parts . . . . .	31	Slight Scoring . . . . .	.45
Pitch Angle . . . . .	49	Spalling . . . . .	.45
Pitch Circle . . . . .	10	Spiral Bevel: . . . . .	.8
Pitch Circle . . . . .	49	Spur Gears . . . . .	.49
Pitch Diameter . . . . .	10, 49	Surface Deterioration . . . . .	44
Pitch Point . . . . .	49	Surface Fatigue . . . . .	.45
Plastic Yielding . . . . .	44	Third Law of Motion . . . . .	.1
Point of Contact . . . . .	49	Tip Relief . . . . .	.49
Power . . . . .	2	Tooth Breakage . . . . .	.46
Pressure Angle . . . . .	.6, 49	Tooth profile . . . . .	.49
Principle Types of Gears . . . . .	6	Tooth surface . . . . .	.49
Pulley . . . . .	3	Top Land . . . . .	.49
Rack and Pinions . . . . .	9	Torque . . . . .	.2
Ratio . . . . .	11	Trigonometric Functions . . . . .	.25
Relationship of Torque to Horsepower . . . . .	4	Undercut . . . . .	.49
Relative Rotation - Thrust . . . . .	33	Wedge . . . . .	.4
Ridging . . . . .	44	Welding . . . . .	.44
Rippling 44		Wheel and Axle . . . . .	.3
Rolling & Scuffing 44		Whole Depth . . . . .	.11, 49
Root Circle 49		Work . . . . .	2
Root Diameter . . . . .	49	Working Depth . . . . .	.11
Rotation . . . . .	.6, 12	Working Depth: . . . . .	.49
Runout . . . . .	49	Worm Gears . . . . .	9, 23, 50
Scratching . . . . .	44	Worms . . . . .	.23
Screw . . . . .	3	Worms & Worm Gears . . . . .	.23

## BIBLIOGRAPHY

Penton Publications, Motion Systems PT design, 2000 Handbook, December 1999A177 - A184.

Power Transmission Distributors Association, Power Transmission Handbook, 1990



Sintered Metal is among the many materials used in the manufacture of *Martin* products.



Our headquarters operation in Arlington, Texas serves as backup inventory for our Service Centers throughout North America.



Plastic is among the many materials used in the manufacture of *Martin* products.

## USA

### General Offices Sales and Manufacturing

#### Arlington, TX

3100 Sprocket Drive 76015-2898  
P.O. Box 91588 • Arlington, Texas 76015-0088  
817-258-3000 (FAX 817-258-3333)

### Sales and Manufacturing

#### Danielsville, PA

3376 Delps Road 18038  
P.O. Box 267 • Danielsville, PA 18038-0267  
610-837-1841 (FAX 610-837-7337)

#### Ft. Worth, TX (Conveyor Division)

3600 McCart Street (76110-4692)  
P.O. Box 1038 • Ft. Worth, TX 76101-1038  
817-258-3000 (FAX 817-258-3173)

#### Mansfield, TX

811 4th Avenue 76063  
P.O. Box 193 • Mansfield, TX 76063-0193  
817-473-1520 (FAX 817-473-0465)

#### Montpelier, OH

350 Airport Road 43544  
P.O. Box 29 • Montpelier, OH 43543-0029  
419-485-5515 (FAX 419-485-3565)

#### Sacramento, CA

1199 Vine Street 95814-0426  
Sacramento, CA 95853-3856  
916-441-7172 (FAX 916-441-4600)

#### Scottsdale, GA

3303 Church Street 30079-1395  
P.O. Box 886 • Scottsdale, GA 30079-0886  
404-292-8744 (FAX 404-292-7771)

#### Ft. Worth, TX (Tool & Forge Division)

3600 McCart Street 76110-4692  
P.O. Box 1038 • Ft. Worth, TX 76101-1038  
817-258-3000 (FAX 817-258-3173)

### Mini Manufacturing Centers

#### Boston, MA

357 Fortune Boulevard  
Milford, MA 01757  
508-634-3990 (FAX 508-634-3998)

#### Charlotte, NC

3901 South I-85 Service Road 28208  
Box 19447 • Charlotte, NC 28219-0447  
704-394-9111 (FAX 704-394-9122)

#### Chicago, IL

1505 Birchwood Avenue  
Des Plaines, IL 60018-3001  
847-298-8844 (FAX 847-298-2967)

#### Denver, CO

10800 East 54th Avenue 80239  
P.O. Box 39208 • Denver CO 80239-0208  
303-371-8466 (FAX 303-371-7116)

#### Houston, TX

9910 Bent Oak Drive 77040  
P.O. Box 41209 • Houston, TX 77241-1209  
713-849-4330 (FAX 713-849-4807)

#### Kansas City, MO

1520 N. Commerce Avenue 64120  
P.O. Box 4961 • Kansas City, MO 64120-4961  
816-231-5575 (FAX 816-231-1959)

#### Los Angeles, CA

5920 S. Triangle Drive  
Commerce, CA 90040-3688  
323-728-8117 (FAX 323-722-7526)

#### Minneapolis, MN

10601 Hampshire Avenue South  
Bloomington, MN 55438-2395  
952-829-0623 (FAX 952-944-9385)

#### Portland, OR

3030 N.W. Industrial  
Portland, OR 97210-0046  
503-223-7261 (FAX 503-221-0203)

#### Tampa, FL

3201 Queen Palm Drive Tampa FL 33619  
813-623-1705 (FAX 813-626-8953)

#### Wayne, NJ

7 High Point Drive

P.O. Box 527 • Wayne, NJ 07470-7432  
973-633-5700 (FAX 973-633-7196)

#### Detroit, MI

12555 Belden Ct.  
Livonia, MI 48150  
734-367-0238 (FAX 734-367-0547)

### Manufacturing Only

#### Abilene, TX

#### Clarksville, TX

#### Dallas, TX

#### Paragould, AR (Includes the Plastics Div.)

## CANADA

### Sales and Manufacturing

#### *Martin* Sprocket & Gear Canada Inc.

896 Meyerside Drive  
Mississauga, Ontario, Canada L5T 1R9  
905-670-1991 (FAX 905-670-2110)

#### *Martin* Sprocket & Gear Canada Inc.

#### (Conveyor Division)

Box C3, RR #1  
Ayr., Ontario, Canada NOB 1E0  
519-621-0546 (FAX 519-621-4413)

## CHINA

#### Shanghai

#### Fuzhou

#### Chengdu

## MEXICO

### Sales and Manufacturing

#### *Martin* Sprocket & Gear de Mexico, S.A. de C.V.

Km 52.8 Carretera, Naucalpan-Toluca  
Parque Industrial, Toluca 2000  
Calle 3, Manzana VII, Lote 11  
Toluca Edo. de Mexico, C.P. 50200  
011-52-72-790023 (FAX 011-52-72-790024)

*Sold by the World's Greatest Sales People. Our Distributors.*

*Martin* SPROCKET & GEAR, INC. • 3100 SPROCKET DR. • ARLINGTON, TX 76015 • 817-258-3000

For more information, contact your nearest *Martin* Distributor or Service Center.