

Bronze Bushed Type

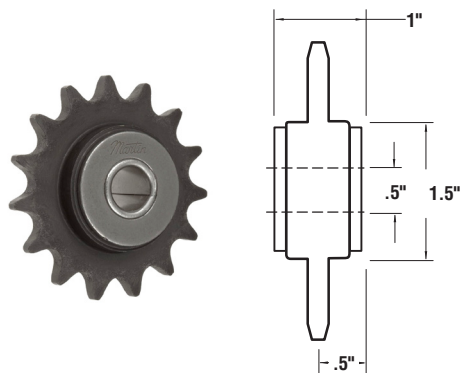

Bronze Bearing Type

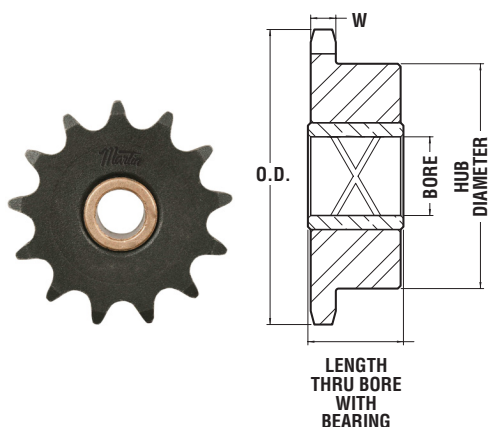

Bronze Bushed Idler Sprocket

No. Teeth	Catalog Number	Chain Size	O.D	Stock Bore	LTB without Bearing	Wt. Lbs.
20	31E20	35	2.6	.5	.75	.46
15	41E15	41-40	2.65	.5	.75	.5
15	51E15	50	3.32	.5	.75	.7
14	61E14	60-60H	3.74	.5	.75	.92

Above idlers have oil impregnated sintered bronze bearings and are mounted on steel journals. Idler RPM to 2500. Radial load rating to 50 pounds.

Bronze Bearing Idler Sprocket

No. Teeth	Catalog Number	Bearing Type	Chain Size	O.D	Stock Bore	LTB without Bearing	LTB with Bearing	W	Hub Dia.	Wt. Lbs.
5	35BR15 1/2	Bronze	35	1.99	.5	.75	.94	.168	1.35	.30
21	35BR21 7/8	Bronze	35	2.71	.875	.88	1.06	.168	2	.75
13	41BR13 1/2	Bronze	41	2.33	.5	.88	.94	.227	1.56	.50
19	41BR19 7/8	Bronze	41	3.29	.875	1	1.06	.227	2.5	1
13	40BR13 1/2	Bronze	40	2.33	.5	.88	.94	.284	1.56	.50
19	40BR19 7/8	Bronze	40	3.29	.875	1	1.06	.284	2.5	1.25
13	50BR13 1/2	Bronze	50	2.91	.5	.88	.94	.343	1.87	.90
17	50BR17 7/8	Bronze	50	3.72	.875	1	1.06	.343	2.62	1.50
15	60BR15 7/8	Bronze	60	3.98	.875	1	1.06	.459	2.62	1.75
17	60BR17 1 1/8	Bronze	60	4.46	1.125	1.25	1.56	.459	3.25	2.75
15	80BR15 1 1/8	Bronze	80	5.3	1.125	1.50	1.56	.575	3.5	4.25

.875" & 1.125" bore have double loop grease groove.

Radial Load Capacity in Pounds at Various Speeds Needle Bearings

Idler Size	RPM					
	100	500	1000	1500	2000	2500
.5 Bore	1021	630	512	453	416	389
1 Bore	2751	1698	1379	1221	1120	1048
1.5 Bore	6306	3891	3160	2798	2567	-

Ratings shown above are based on an average bearing life of 2500 hours.

Needle Bearing Type

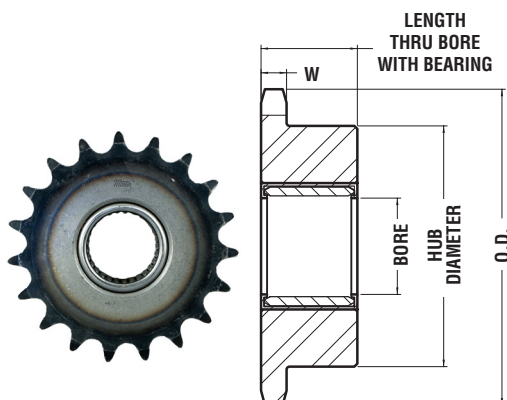

Needle Bearing Idler Sprocket

No. Teeth	Catalog Number	Bearing Type	Chain Size	O.D	Stock Bore	LTB without Bearing	LTB with Bearing	W	Hub Dia.	Wt. Lbs.
19	25NB19H 1/2	Needle	25	1.65	.5	.75	.75	.11	1.22	.1
13	35NB13H 1/2	Needle	35	1.75	.5	.75	.75	.168	1.18	.2
19	35NB19H 1	Needle	35	2.47	1	1	1	.168	1.84	.5
19	41NB19H 1	Needle	41	3.29	1	1	1	.227	2.5	1
19	40NB19H 1	Needle	40	3.29	1	1	1	.284	2.5	1.1
17	50NB17H 1	Needle	50	3.72	1	1	1	.343	2.25	1.3
17	60NB17H 1	Needle	60	4.46	1	1	1	.459	3	2.6
13	80NB13H 1	Needle	80	4.66	1	1.25	1.25	.575	2.63	2.9
11	100NB11H 1 1/2	Needle	100	5.01	1.5	1.88	1.88	.692	3.56	3.6
11	120NB11H 1 1/2	Needle	120	6.01	1.5	2.13	2.13	.924	3.56	7
11	140NB11H 1 1/2	Needle	140	7.01	1.5	2.25	2.25	.924	4.25	1.9
9	160NB9H 1 1/2	Needle	160	6.7	1.5	2.25	2.25	1.156	3.63	9.6

Idler Sprockets



Ball Bearing Idler Sprocket – Hardened Teeth

No. Teeth	Discontinued Part Number	Catalog Number	Bearing Type	Chain Size	O.D.	Stock Bore	LTB Without Bearing	LTB With Bearing	W	Wt. Lbs.
20		25BB20 3/8 *	Ball	25	1.73	.394	.11	.35	.11	.1
19		35BB19H 3/8	Ball	35	2.47	.394	.38	.38	.168	.35
19		35BB19H 1/2	Ball	35	2.47	.51	.48	.72	.168	.35
20	35BB20H	35BB20H 5/8	Ball	35	2.59	.638	.48	.72	.168	.38
18		41BB18H 1/2	Ball	41	3.14	.51	.48	.72	.227	.51
18		41BB18H 5/8	Ball	41	3.14	.638	.48	.72	.227	.51
17	40BB17H	40BB17H 5/8	Ball	40	2.97	.638	.48	.72	.284	.52
18		40BB18H 1/2	Ball	40	3.14	.51	.48	.72	.284	.53
18	40BB18H	40BB18H 5/8	Ball	40	3.14	.638	.48	.72	.284	.53
25		40BB25H 5/8	Ball	40	4.26	.638	.48	.72	.284	.9
35		40BB35H 5/8	Ball	40	5.86	.638	.48	.72	.284	1.77
48		40BB48H 5/8	Ball	40	7.93	.638	.22	.72	.284	3.37
15	50BB15H	50BB15H 5/8	Ball	50	3.32	.638	.48	.72	.343	.75
17		50BB17H 1/2	Ball	50	3.72	.51	.48	.72	.343	.78
17	50BB17H	50BB17H 5/8	Ball	50	3.72	.638	.48	.72	.343	.78
25		50BB25H 3/4	Ball	50	5.32	.75	.59	.61	.343	1.66
39		50BB39H 3/4	Ball	50	8.12	.75	.32	.61	.343	4.09
12		60BB12H 5/8	Ball	60	3.25	.638	.48	.72	.459	.72
13	60BB13H	60BB13H 5/8	Ball	60	3.49	.638	.48	.72	.459	.76
15		60BB15H 1/2	Ball	60	3.98	.51	.48	.72	.459	1.06
15	60BB15H	60BB15H 5/8	Ball	60	3.98	.638	.48	.72	.459	1.06
17		60BB17H 5/8	Ball	60	4.46	.638	.48	.72	.459	1.1
12	80BB12H	80BB12H 3/4	Ball	80	4.33	.75	.59	.61	.575	1.5

Note: .394 Stock Bore is +.000 .0003; .510 Stock Bore is +.005 .000; .638 Stock Bore is +.005 .000; .750 Stock Bore is +.005 .000. Discontinued Part Numbers will be replaced with Catalog Number when existing inventory is exhausted.

* Unhardened Teeth

Ball Bearing Type

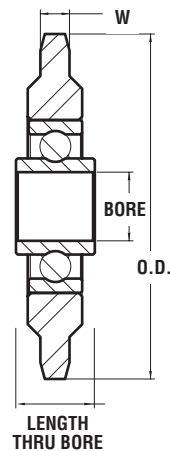

Ball Bearing Idler Sprockets – Non Metallic Teeth

No. Teeth	Catalog Number	Bearing Type	Chain Size	O.D.	Stock Bore	LTB Without Bearing	LTB With Bearing	W	Wt. Lbs.
17	40BB17NM 1/2	Ball	40	2.97	.510	0.72	.72	.284	.24
18	40BB18NM 5/8	Ball	40	3.14	.638	0.72	.72	.284	.23
17	50BB17NM 1/2	Ball	50	3.72	.510	0.72	.72	.343	.29
18	50BB18NM 5/8	Ball	50	3.92	.638	0.72	.72	.343	.29
15	60BB15NM 1/2	Ball	60	3.98	.510	0.72	.72	.459	.32
16	60BB16NM 5/8	Ball	60	4.22	.638	0.72	.72	.459	.33
12	80BB12NM 3/4	Ball	80	4.33	.750	0.96	.61	.575	.44

Note: .510 Stock Bore is +.005 .000; .638 Stock Bore is +.005 .000; .750 Stock Bore is +.005 .000

Non-Metallic Teeth Ball Bearing Type

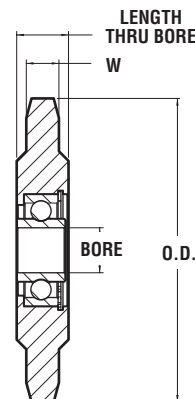

Radial Load Capacity in Pounds at Various Speeds Ball Bearings

Idler Size	RPM					
	100	500	1000	1500	2000	2500
.375" Bore	620	363	288	252	229	212
.5" & .625" Bore	800	460	360	320	290	270
.75" Bore	1290	755	600	523	478	440

Ratings shown above are based on an average bearing life of 2500 hours.

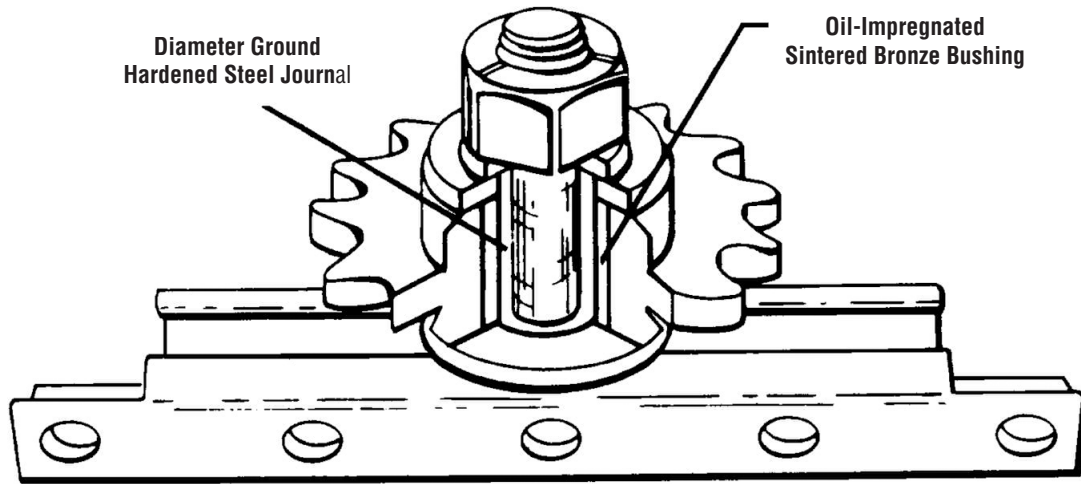

Chain Tightener (Less Idler Sprocket)

No. E-5006

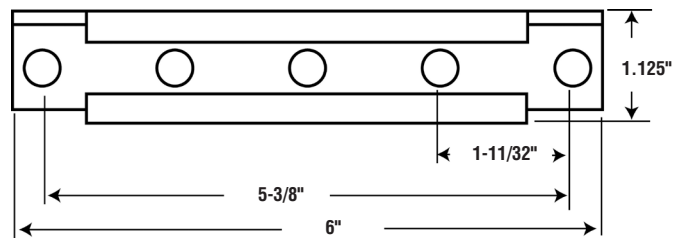
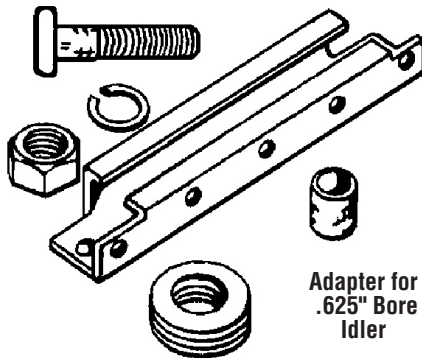

Attachment Bolts Not
Furnished

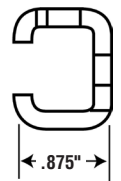

Attachments Holes
for 5/16" Bolts

Martin Chain Tighteners are economical to use, provide everything needed for a quick, easy installation, save time and money, there is no need to design, procure or custom make and assemble separate parts, accommodate mounting in several different positions, can be parallel or at 90° to the mounting surface, can be used as cantilever or attached each end.

Features of Martin Idlers

Smooth-running, oil-impregnated, sintered bronze, extra-duty bearing press-fitted in sprocket. Steel journal case hardened, for maximum resistance to wear, diameter ground surface for free running under load.

Steel sprockets used in Martin Idlers, are accurately machined (not stamped) the same as sprockets normally supplied for power transmission use.