

Sprocket Engineering Data

- Roller Chain Dimensions
- Sprocket Tooth Dimensions
- Maximum Hub Recommendations
- Application And Selection
- Hardening
- Chain Length Calculation
- Speed Ratios
- Sprocket Diameters
- Horsepower Ratings

Sprockets

American sprocket manufacturers have adopted 4 specific types of sprocket construction styles as American Standards. In addition to the standard sprockets, special sprockets may be available in the same styles.

- Style A** - Flat sprocket with no hub extension either side.
- Style B** - Sprocket with hub extension one side.
- Style C** - Sprocket with hub extension both sides.
- Style D** - Sprocket with a detachable bolt on hub attached to a plate.

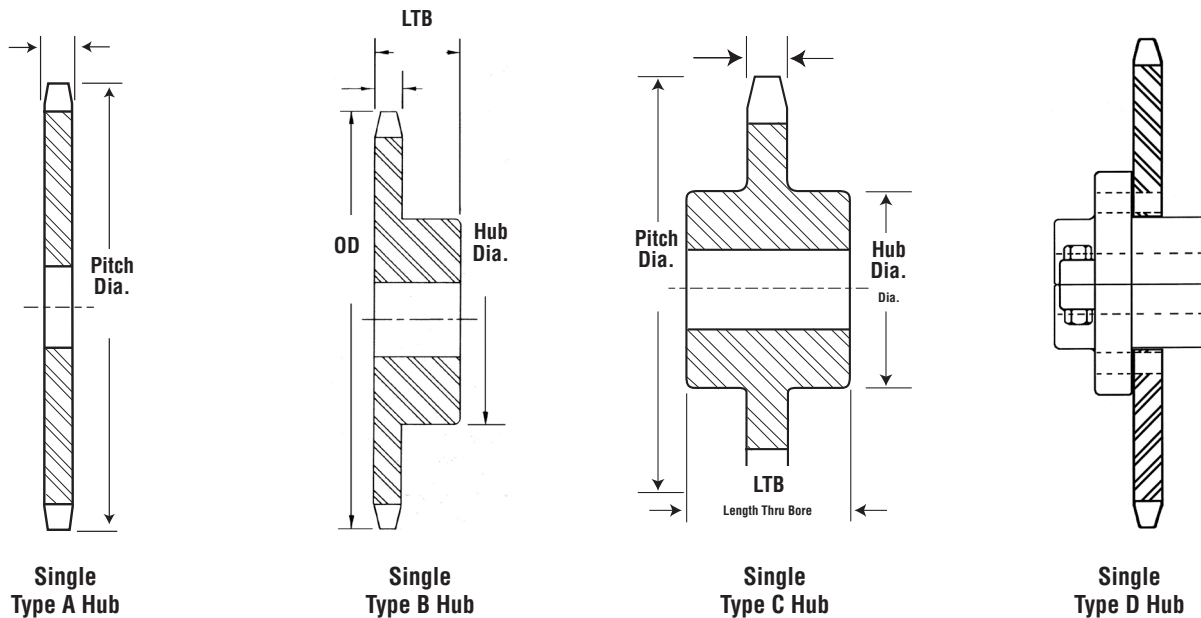

Multiple Strand Sprockets

Listed using a letter prefix starting with the letter D for Double Strand, E for Triple Strand, and F for Quadruple, etc. They also have the same hub configuration letter designation listed on previous page. In addition to the four specific types, sprockets may also be made in various other styles.

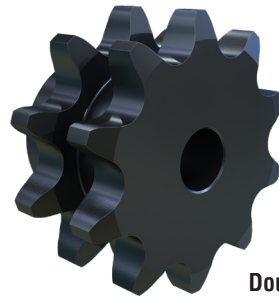

Double



Triple

Five common styles are:

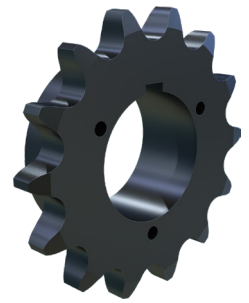
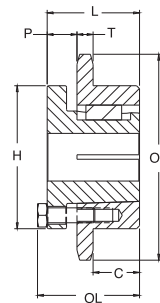
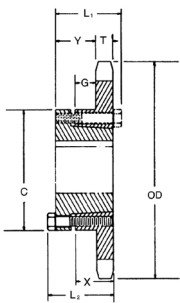

QD

The QD (quick detachable) sprocket; here a tapered bushing is bolted into the bore machined in the sprocket. This bushing, when inserted into the sprocket, compresses onto the shaft providing a tight grip.

MST®

The MST® (Martin Split Taper®) is another style of bushed sprocket. The bushing is similar to the QD style except it has an external key that fits into the driven product.

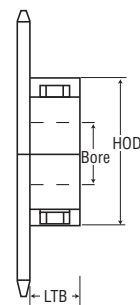
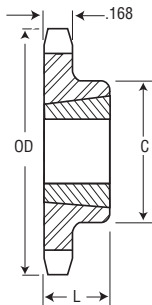

TB

The TB (taper bushed) sprocket is another style of an interchangeable bushed sprocket, which provides a positive grip on a driven shaft.

Split

A Split type sprocket is used in place of solid type to allow quick installation without disruption of shaft and alignment.

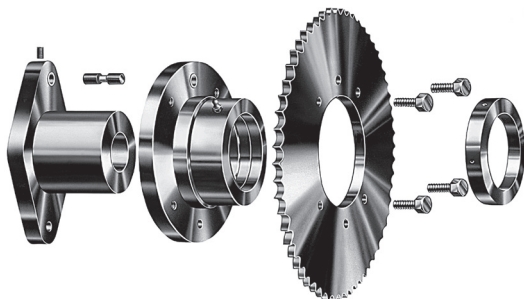

Shear Pin Sprocket

Sprocket Nomenclature



Sprocket nomenclatures provide the chain pitch written to the left of the hub style code letter followed by the number of teeth in the sprocket. If the sprocket is to be multiple strand, the prefix code letter is added to the beginning of the part number.

A suffix of H is added if the teeth are to be heat treated. If the sprocket is to be bored for QD, Taper Bushed or MST, the center hub letter is changed. For QD and MST styles the letter designation of the bushing is used in lieu of the hub style code. If a taper bushing is to be used, the two letters TB are added behind the hub code letter.

In some instances, the material a sprocket is to be manufactured from will be added into the part number as a suffix.

For example:

- SS** Stainless Steel Material
- NM** Non-Metallic
- BR** Brass or Bronze Material
- CD** Cadmium Plated
- Zi** Zinc Plated
- Ni** Nickel Plated
- CH** Chrome Plated

If the part is to be used with a shear pin device, the center hub style letter is substituted with an SP.

Most manufacturers of sprockets conform to the ANSI (American Standards Institute) and Martin conforms to the Type II tooth form as given in the standard B29.1 - 1975. It is not necessary to show detailed tooth information on sprocket drawings, just specify ANSI standard tooth form.

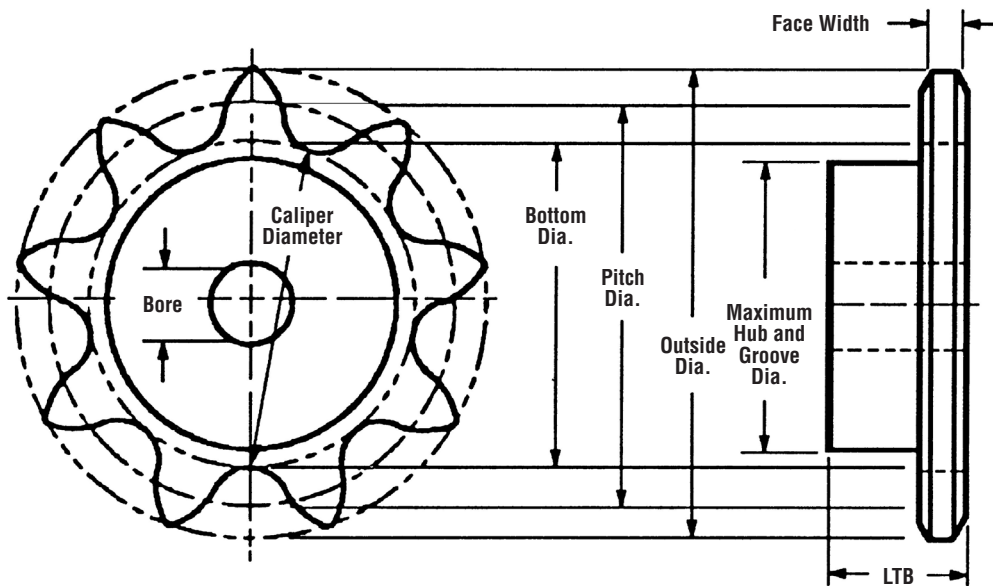

Sprocket Dimensional Specifications

Bottom Diameter (BD)

The diameter of a circle tangent to the bottoms of the tooth spaces.

Caliper Diameter

Since the bottom diameter of a sprocket with odd number of teeth cannot be measured directly, caliper diameters are the measurement across the tooth spaces nearly opposite.

Pitch Diameter (PD)

The diameter across to the pitch circle which is the circle followed by the centers of the chain pins as the sprocket revolves in mesh with the chain.

$$PD = \frac{\text{Pitch}}{\text{SIN } (180/Nt)}$$

Outside Diameter (OD)

The measurement from the tip of the sprocket tooth across to the corresponding point directly across the sprocket. It is comparatively unimportant as the tooth length is not vital to proper meshing with the chain. The outside diameter may vary depending on type of cutter used.

$$OD = (\text{Pitch}) (.6 + \text{COT } [180 / Nt])$$

Hub Diameter (HOD)

That distance across the hub from one side to another. That distance across the hub from one side to another.

Maximum Sprocket Bore

Maximum Sprocket Bore is determined by the required hub wall thickness for proper strength. Allowance must be made for keyway and setscrews.

Face Width

Face width is limited in its maximum dimension to allow proper clearance to provide for chain engagement and disengagement. The minimum width is limited to provide the proper strength to carry the imposed loads.

Length Thru Bore (LTB)

Length Thru Bore (or LTB) must be sufficient to allow a long enough key to withstand the torque transmitted by the shaft. This also assures stability of the sprocket on the shaft.

Roller Chain Dimensions



ANSI Number	Roller Width	Roller Dia.	Inside Link Plate Height	Cottered Chain Width*	Riveted Chain Width*	Average Tensile Strength
Standard Series Chain						
25	1/8	.130	.237	.37	.34	875
25-2	1/8	.130	.237	.63	.59	1750
25-3	1/8	.130	.237	.88	.84	2626
35	3/16	.200	.356	.56	.50	2100
35-2	3/16	.200	.356	.96	.90	4200
35-3	3/16	.200	.356	1.36	1.31	6300
35-4	3/16	.200	.356	1.76	1.70	8400
35-5	3/16	.200	.356	2.16	2.11	10500
35-6	3/16	.200	.356	2.57	2.51	12600
40	5/16	.312	.475	.72	.67	3700
40-2	5/16	.312	.475	1.29	1.24	7400
40-3	5/16	.312	.475	1.85	1.80	11100
40-4	5/16	.312	.475	2.42	2.37	14800
40-6	5/16	.312	.475	3.56	3.51	22200
41	1/4	.306	.383	.65	.57	2000
50	3/8	.400	.594	.89	.83	6600
50-2	3/8	.400	.594	1.60	1.55	13200
50-3	3/8	.400	.594	2.31	2.26	19800
50-4	3/8	.400	.594	3.03	2.97	26400
50-5	3/8	.400	.594	3.75	3.69	33000
50-6	3/8	.400	.594	4.46	4.40	39600
60	1/2	.469	.712	1.11	1.04	8500
60-2	1/2	.469	.712	2.01	1.94	17000
60-3	1/2	.469	.712	2.91	2.84	25500
60-4	1/2	.469	.712	3.81	3.74	34000
60-5	1/2	.469	.712	4.71	4.64	42500
60-6	1/2	.469	.712	5.60	5.53	51000
80	5/8	.625	.950	1.44	1.32	14500
80-2	5/8	.625	.950	2.59	2.47	29000
80-3	5/8	.625	.950	3.74	3.62	43500
80-4	5/8	.625	.950	4.90	4.79	58000
80-5	5/8	.625	.950	6.06	5.94	72500
80-6	5/8	.625	.950	7.22	7.10	87000

*Dimensions are across pins.

ANSI Number	Roller Width	Roller Dia.	Inside Link Plate Height	Cottered Chain Width*	Riveted Chain Width*	Average Tensile Strength
Standard Series Chain						
100	3/4	.750	1.187	1.73	1.61	24000
100-2	3/4	.750	1.187	3.14	3.02	48000
100-3	3/4	.750	1.187	4.56	4.43	72000
100-4	3/4	.750	1.187	5.97	5.84	96000
100-5	3/4	.750	1.187	7.38	7.25	120000
100-6	3/4	.750	1.187	8.78	8.66	144000
120	1	.875	1.425	2.14	2.00	34000
120-2	1	.875	1.425	3.93	3.79	68000
120-3	1	.875	1.425	5.72	5.58	102000
120-4	1	.875	1.425	7.52	7.38	136000
120-5	1	.875	1.425	9.31	9.17	170000
120-6	1	.875	1.425	11.10	10.96	204000
140	1	1.000	1.662	2.31	2.14	46000
140-2	1	1.000	1.662	4.24	4.07	92000
140-3	1	1.000	1.662	6.16	6.00	138000
140-4	1	1.000	1.662	8.09	7.93	184000
140-6	1	1.000	1.662	11.94	11.78	276000
160	1 1/4	1.125	1.900	2.73	2.54	58000
160-2	1 1/4	1.125	1.900	5.04	4.85	116000
160-3	1 1/4	1.125	1.900	7.35	7.16	174000
160-4	1 1/4	1.125	1.900	9.66	9.47	232000
160-6	1 1/4	1.125	1.900	14.27	14.09	348000
180	1 13/32	1.406	2.137	3.15	2.88	76000
180-2	1 13/32	1.406	2.137	5.75	5.48	152000
180-3	1 13/32	1.406	2.137	8.34	8.07	228000
200	1 1/2	1.562	2.375	3.44	3.12	95000
200-2	1 1/2	1.562	2.375	6.26	5.94	190000
200-3	1 1/2	1.562	2.375	9.08	8.76	285000
200-4	1 1/2	1.562	2.375	11.90	11.58	380000
200-6	1 1/2	1.562	2.375	17.52	17.21	570000
240	1 7/8	1.875	2.812	4.06	3.72	130000
240-2	1 7/8	1.875	2.812	7.52	7.18	260000

*Dimensions are across pins.

Standard Keyways and Setscrews

Diameter of Shaft	Keyway Width x Depth	Setscrew	Diameter of Shaft	Keyway Width x Depth	Setscrew
1/2 - 9/16	1/8 x 1/16	10-24	2 5/16 - 2 3/4	5/8 x 5/16	5/8 *
5/8 - 7/8	3/16 x 3/32	1/4	2 13/16 - 3 1/4	3/4 x 3/8	5/8 *
15/16 - 1 1/4	1/4 x 1/8	5/16	3 5/16 - 3 3/4	7/8 x 7/16	3/4
1 5/16 - 1 3/8	5/16 x 5/32	5/16	3 13/16 - 4 1/2	1 x 1/2	3/4
1 7/16 - 1 3/4	3/8 x 3/16	3/8	4 9/16 - 5 1/2	1 1/4 x 5/8	3/4
1 13/16 - 2 1/4	1/2 x 1/4	1/2 *	5 9/16 - 6 1/2	1 1/2 x 3/4	3/4

*Hub size may require smaller setscrews in some instances.

Standard Bore Tolerances

1" and Less	+ .001 - .000
1 1/16" to 2"	+ .002 - .000
2 1/16" to 3"	+ .003 - .000
3 1/16" & up	+ .004 - .000

Bores with closer tolerances will be supplied at a slight increase in price.

Sprocket Tooth Dimensions

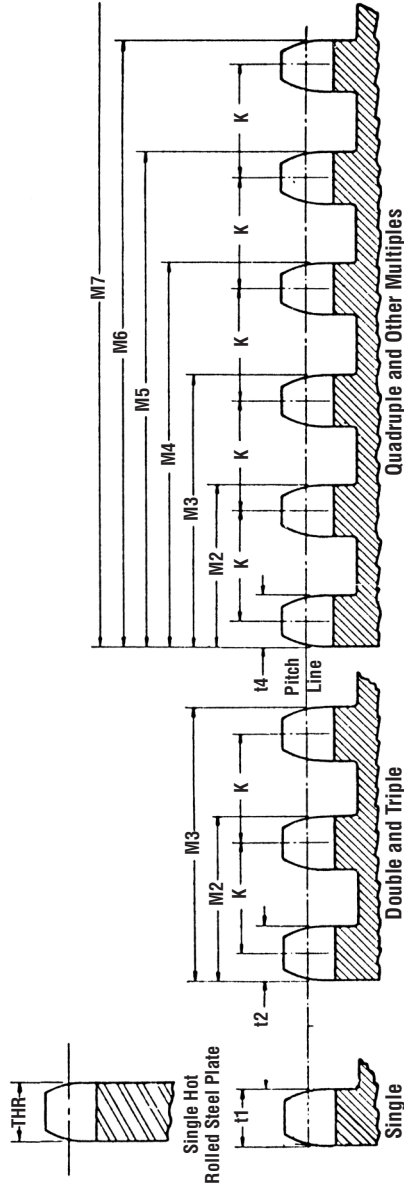

Dimensions in Inches

Chain Data For All Sprockets				Double and Triple Strand		For 4 or more Strands										Tolerance Minus Tolerance on THR Machined					
ASA Chain No.	Pitch P	Roller Width W	Roller Dia.	Single Strand T1 & T2		14	M2	M3	M4	M5	M6	M8	M10	M12	M16		K				
Standard Series Roller Chain Sprockets																					
25	.25	.125	.130	.110	.107	.359	.611	.096	.348	.600	.852	1.104	1.356	1.860	2.364	2.868	3.876	.252	.007	.021	
35	.375	.188	.200	.168	.162	.561	.960	.149	.548	.947	1.346	1.745	2.144	2.942	3.740	4.538	6.134	.399	.008	.027	
41	.5	.25	.306	.227	†	†	†	†	†	†	†	†	†	†	†	†	†	†	.009	.032	.035
40	.5	.313	.312	.284	.275	.841	1.407	.256	.822	1.388	1.954	2.520	3.086	4.218	5.250	6.482	8.746	.566	.009	.035	
50	.625	.375	.400	.343	.332	1.045	1.758	.311	1.024	1.737	2.450	3.163	3.876	5.302	6.728	8.154	11.006	.713	.010	.036	
60	.75	.5	.469	.459	.444	1.341	2.238	.418	1.315	2.212	3.108	4.006	4.903	6.697	8.491	10.258	13.873	.897	.011	.036	
80	1	.625	.625	.575	.557	1.700	2.863	.526	1.679	2.832	3.985	5.138	6.291	8.597	10.903	13.209	17.821	1.153	.012	.040	
100	1.25	.75	.750	.692	.669	2.077	3.484	.633	2.041	3.449	4.857	6.265	7.673	10.489	13.305	16.121	21.753	1.408	.014	.046	
120	1.5	1	.875	.924	.894	2.683	4.472	.848	2.637	4.426	6.215	8.004	9.793	13.371	16.949	20.527	28.012	1.789	.016	.057	
140	1.75	1	1.000	.924	.894	3.214	5.281	.948	3.151	5.119	7.083	9.047	11.011	14.316	18.164	22.012	30.012	1.924	.016	.057	
160	2	1.25	1.125	1.156	1.119	3.424	5.729	1.063	3.368	5.673	7.978	10.283	12.588	17.198	21.808	27.418	36.012	2.305	.019	.062	
180	2.25	1.406	1.406	1.301	1.259	3.851	6.443	1.197	3.789	6.381	8.973	11.566	14.157	19.341	25.012	31.602	40.012	2.592	.020	.068	
200	2.5	1.5	1.562	1.389	1.344	4.161	6.978	1.278	4.095	6.912	9.729	12.546	15.363	20.997	27.418	34.812	44.012	2.817	.021	.072	
240	3	1.875	1.875	1.738	1.682	5.140	8.598	1.601	5.059	8.517	11.975	15.433	18.891	25.412	32.812	41.602	51.602	3.458	.025	.087	
Heavy Series Chain Sprockets																					
60H	.750	.500	.469	.459	.444	1.472	2.500	.418	1.446	2.474	3.502	4.530	5.558	7.614	9.670	11.726	15.433	1.028	.011	.036	
80H	1.000	.625	.625	.575	.557	1.840	3.123	.526	1.809	3.092	4.375	5.658	6.941	9.507	11.726	14.941	19.602	1.283	.012	.040	
100H	1.250	.750	.750	.692	.669	2.208	3.747	.633	2.172	3.711	5.250	6.789	8.328	11.406	14.481	18.164	23.412	1.539	.014	.046	
120H	1.500	1.000	.875	.924	.894	2.818	4.742	.848	2.772	4.696	6.620	8.544	10.468	14.316	18.164	23.412	30.012	1.924	.016	.057	
140H	1.750	1.000	1.000	.924	.894	2.949	5.004	.848	2.903	4.958	7.013	9.068	11.123	15.233	19.341	24.412	30.012	2.055	.016	.057	
160H	2.000	1.250	1.125	1.156	1.119	3.555	5.991	1.063	3.499	5.935	8.371	10.807	13.243	18.115	23.012	28.812	36.012	2.436	.019	.062	
180H	2.250	1.406	1.406	1.301	1.259	3.982	6.705	1.197	3.920	6.643	9.366	12.089	14.812	20.258	26.012	32.812	40.012	2.723	.020	.068	
200H	2.500	1.500	1.562	1.389	1.344	4.427	7.510	1.278	4.361	7.444	10.527	13.610	16.693	22.859	29.602	37.412	45.602	3.083	.021	.072	

† = Not made in multiple strands.

Maximum Hub Dimensions



Recommended Max. Hub and Bore Sizes

American Standard No. 25

No. of Teeth	Max RPM	Max Hub	Max Bore	No. of Teeth	Max RPM	Max Hub	Max Bore	No. of Teeth	Max RPM	Max Hub	Max Bore	Std. Keyway (Am. Std.) and Setscrew				
												Diameter of Shaft	Keyway Width x Depth	Dia. of Set-Screw	Min. Added To Bore For Adequate Hub Wall Steel Sprockets	
															Setscrew Over Key	Setscrew not over key
6	555	9/64	16	6940	31/32	9/16	26	8645	1 49/64	1 1/4	3/8	3/16	7/16	3/8	
7	1300	15/64	17	7290	1 3/64	5/8	27	8655	1 55/64	1 1/4	3/8	3/16	15/32	3/8	
8	2080	5/16	18	7590	1 1/8	3/4	28	8650	1 15/16	1 1/4	3/8	3/16	1/2	3/8	
9	2860	7/16	1/4	19	7840	1 7/32	13/16	29	8625	2 1/64	1 1/4	3/8	3/16	11/16	1/2	
10	3610	1/2	1/4	20	8050	1 19/64	7/8	30	8580	2 3/32	1 5/16	3/8	3/16	15/32	3/8	
11	4310	9/16	5/16	21	8230	1 3/8	7/8	31	8540	2 11/64	1 3/8	3/8	3/16	1/2	3/8	
12	4960	41/64	3/8	22	8370	1 29/64	15/16	32	8465	2 1/4	1 1/2	3/8	1/4	11/16	1/2	
13	5540	47/64	7/16	23	8480	1 17/32	1	35	8200	2 31/64	1 11/16	3/8	1/4	3/4	1/2	
14	6070	13/16	9/16	24	8560	1 39/64	1 1/16	40	7580	2 57/64	1 7/8	3/8	5/16	15/16	5/8	
15	6530	57/64	9/16	25	8610	1 11/16	1 3/16	45	6820	3 9/32	2 1/4	3/8	3/8	1 1/8	3/4	

American Standard No. 35

No. of Teeth	Max RPM	Max Hub	Max Bore	No. of Teeth	Max RPM	Max Hub	Max Bore	No. of Teeth	Max RPM	Max Hub	Max Bore	Std. Keyway (Am. Std.) and Setscrew				
												Diameter of Shaft	Keyway Width x Depth	Dia. of Set-Screw	Min. Added To Bore For Adequate Hub Wall Steel Sprockets	
															Setscrew Over Key	Setscrew not over key
6	290	15/64	16	3630	1 15/32	15/16	26	4525	2 43/64	1 3/4	3/8	3/16	15/32	3/8	
7	680	3/8	17	3810	1 19/32	1 1/16	27	4530	2 51/64	1 3/4	3/8	3/16	1/2	3/8	
8	1090	1/2	1/4	18	3970	1 23/32	1 3/16	28	4525	2 59/64	1 7/8	3/8	3/16	1/2	3/8	
9	1495	5/8	3/8	19	4100	1 27/32	1 1/4	29	4510	3 1/32	2	3/8	1/4	11/16	1/2	
10	1885	3/4	1/2	20	4210	1 61/64	1 1/4	30	4490	3 5/32	2 1/8	3/8	1/4	3/4	1/2	
11	2260	55/64	9/16	21	4300	2 5/64	1 5/16	31	4470	3 9/32	2 1/4	3/8	1/4	11/16	1/2	
12	2590	63/64	9/16	22	4380	2 13/64	1 7/16	32	4430	3 25/64	2 1/4	3/8	1/4	3/4	1/2	
13	2900	1 7/64	11/16	23	4430	2 5/16	1 9/16	35	4290	3 3/4	2 1/2	3/8	5/16	15/16	5/8	
14	3170	1 15/64	13/16	24	4480	2 7/16	1 11/16	40	3970	4 23/64	2 13/16	3/8	3/8	1 1/8	3/4	
15	3420	1 23/64	7/8	25	4510	2 9/16	1 3/4	45	3570	4 61/64	3 1/4	3/8	1/2	1 1/2	1	

American Standard No. 41

No. of Teeth	Max RPM	Max Hub	Max Bore	No. of Teeth	Max RPM	Max Hub	Max Bore	No. of Teeth	Max RPM	Max Hub	Max Bore	Std. Keyway (Am. Std.) and Setscrew				
												Diameter of Shaft	Keyway Width x Depth	Dia. of Set-Screw	Min. Added To Bore For Adequate Hub Wall Steel Sprockets	
															Setscrew Over Key	Setscrew not over key
6	130	27/64	1/8	16	1630	2 1/16	1 5/16	26	2040	3 43/64	2 3/8	3/8	1/4	11/16	1/2	
7	305	19/32	5/16	17	1720	2 15/64	1 7/16	27	2040	3 53/64	2 9/16	3/8	1/4	3/4	1/2	
8	495	49/64	1/2	18	1790	2 25/64	1 7/8	28	2040	4	2 3/4	3/8	1/4	3/4	1/2	
9	675	15/16	9/16	19	1850	2 35/64	1 3/4	29	2040	4 5/32	2 3/4	3/8	1/4	11/16	1/2	
10	850	1 3/32	11/16	20	1890	2 23/32	1 3/4	30	2020	4 5/16	2 13/16	3/8	1/4	3/4	1/2	
11	1020	1 17/64	7/8	21	1940	2 7/8	1 7/8	31	2020	4 15/32	2 15/16	3/8	1/4	11/16	1/2	
12	1170	1 27/64	7/8	22	1970	3 1/32	2	32	2000	4 41/64	3 1/8	3/8	1/4	1 1/8	3/4	
13	1310	1 37/64	1 1/16	23	2000	3 3/16	2 3/16	35	1930	5 7/64	3 5/16	3/8	1/2	1 1/2	1	
14	1430	1 3/4	1 1/4	24	2020	3 23/64	2 1/4	40	1780	5 29/32	3 7/8	3/8	5/8	1 7/8	1 1/4	
15	1540	1 29/32	1 1/4	25	2030	3 33/64	2 1/4	45	1600	6 45/64	4 15/16	3/8	3/4	2 1/4	1 1/2	

American Standard No. 40

No. of Teeth	Max RPM	Max Hub	Max Bore	No. of Teeth	Max RPM	Max Hub	Max Bore	No. of Teeth	Max RPM	Max Hub	Max Bore	Std. Keyway (Am. Std.) and Setscrew				
												Diameter of Shaft	Keyway Width x Depth	Dia. of Set-Screw	Min. Added To Bore For Adequate Hub Wall Steel Sprockets	
															Setscrew Over Key	Setscrew not over key
6	220	21/64	16	2720	1 63/64	1 1/4	26	3400	3 37/64	2 5/16	3/8	1/4	11/16	1/2	
7	510	1/2	1/4	17	2860	2 9/64	1 5/16	27	3405	3 47/64	2 7/16	3/8	1/4	3/4	1/2	
8	820	43/64	3/8	18	2980	2 19/64	1 1/2	28	3405	3 29/32	2 5/8	3/8	1/4	3/4	1/2	
9	1125	27/32	9/16	19	3080	2 29/64	1 11/16	29	3395	4 1/16	2 3/4	3/8	1/4	11/16	1/2	
10	1420	1	5/8	20	3160	2 5/8	1 3/4	30	3370	4 7/32	2 3/4	3/8	1/4	3/4	1/2	
11	1690	1 11/64	3/4	21	3230	2 25/32	1 3/4	31	3360	4 3/8	2 7/8	3/8	1/4	11/16	1/2	
12	1940	1 21/64	7/8	22	3290	2 15/16	1 15/16	32	3330	4 35/64	3	3/8	1/4	1 1/8	3/4	
13	2180	1 1/2	1	23	3330	3 3/32	2 1/16	35	3220	5 1/64	3 1/4	3/8	1/2	1 1/2	1	
14	2380	1 21/32	1 1/8	24	3360	3 17/64	2 1/4	40	2970	5 13/16	3 13/16	3/8	5/8	1 7/8	1 1/4	
15	2560	1 13/16	1 1/4	25	3380	3 27/64	2 1/4	45	2670	6 39/64	4 13/16	3/8	3/4	2 1/4	1 1/2	

American Standard No. 50

No. of Teeth	Max RPM	Max Hub	Max Bore	No. of Teeth	Max RPM	Max Hub	Max Bore	No. of Teeth	Max RPM	Max Hub	Max Bore	Std. Keyway (Am. Std.) and Setscrew				
												Diameter of Shaft	Keyway Width x Depth	Dia. of Set-Screw	Min. Added To Bore For Adequate Hub Wall Steel Sprockets	
															Setscrew Over Key	Setscrew not over key
6	155	27/64	1/8	16	1960	2 31/64	1 11/16	26	2445	4 31/64	2 15/16	3/8	1/4	11/16	1/2	
7	370	41/64	3/8	17	2060	2 11/16	1 3/4	27	2450	4 11/16	3 3/16	3/8	1/4	3/4	1/2	
8	590	27/32	9/16	18	2150	2 57/64	1 7/8	28	2445	4 57/64	3 1/4	3/8	1/4	3/4	1/2	
9	810	1 1/16	11/16	19	2220	3 5/64	2 1/16	29	2440	5 5/64	3 5/16	3/8	1/4	11/16	1/2	
10	1020	1 17/64	7/8	20	2280	3 9/32	2 1/4	30	2430	5 9/32	3 1/2	3/8	1/4	3/4	1/2	
11	1220	1 15/32	15/16	21	2330	3 31/64	2 1/4	31	2415	5 31/64	3 11/16	3/8	1/4	11/16	1/2	
12	1400	1 43/64	1 1/8	22	2370	3 11/16	2 7/8	32	2395	5 11/16	3 3/4	3/8	1/4	1 1/8	3/4	
13	1570	1 7/8	1 1/4	23	2400	3 57/64	2 5/8	35	2320	6 9/32	4 9/32	3/8	1/2	1 1/2	1	
14	1720	2 5/64	1 5/16	24	2420	4 5/64	2 3/4	40	2140	7 9/32	5 1/2	3/8	5/8	1 7/8	1 1/4	
15	1850	2 9/32	1 1/2	25	2440	4 9/32	2 3/4	45	1930	8 9/32	6 1/4	3/8	3/4	2 1/4	1 1/2	

American Standard No. 60

No. of Teeth	Max RPM	Max Hub	Max Bore	No. of Teeth	Max RPM	Max Hub	Max Bore	No. of Teeth	Max RPM	Max Hub	Max Bore	Std. Keyway (Am. Std.) and Setscrew				
												Diameter of Shaft	Keyway Width x Depth	Dia. of Set-Screw	Min. Added To Bore For Adequate Hub Wall Steel Sprockets	
															Setscrew Over Key	Setscrew not over key
6	120	33/64	1/4	16	1480	2 63/64	1 15/16	26	1840	5 25/64	3 5/8	3/8	1/4	3/4	1/2	
7	275	49/64	1/2	17	1550	3 7/32	2 3/16	27	1845	5 5/8	3 3/4	3/8	1/4	3/4	1/2	
8	445	1 1/32	5/8	18	1610	3 15/32	2 1/4	28	1840	5 7/8	3 7/8	3/8	1/4	3/4	1/2	
9	610	1 9/32	7/8	19	1670	3 45/64	2 1/16	29	1835	6 7/64	4 1/16	3/8	1/4	3/4	1/2	
10	770	1 33/64	1	20	1720	3 61/64	2 11/16	30	1830	6 11/32	4 9/16	3/8	1/4	3/4	1/2	
11	920	1 49/64	1 1/4	21	1750	4 3/16	2 3/4	31	1815	6 19/32	4 13/16	3/8	1/4	3/4	1/2	
12	1050	2 1/64	1 1/4	22	1780	4 7/16	2 15/16	32	1800	6 53/64	5 1/16	3/8	1/2	1 1/2	1	
13	1180	2 1/4	1 1/2	23	1800	4 43/64	3 1/8	35	1740	7 35/64	5 1/2	3/8	5/8	1 7/8	1 1/4	
14	1290	2 1/2	1 3/4	24	1820	4 29/32	3 1/4	40	1610	8 3/4	6 1/2	3/8	3/4	2 1/4	1 1/2	
15	1390	2 3/4	1 3/4	25	1830	5 5/32	3 3/8	45	1450	9 15/16	7 7/16	3/8	3/4	2 3/8	1 3/4	

Recommended Max. Hub and Bore Sizes

American Standard No. 80

American Standard No. 80												Std. Keyway (Am. Std.) and Setscrew				
No. of Teeth	Max RPM	Max Hub	Max Bore	No. of Teeth	Max RPM	Max Hub	Max Bore	No. of Teeth	Max RPM	Max Hub	Max Bore	Diameter of Shaft	Keyway Width x Depth	Dia. of Set-Screw	Min. Added To Bore For Adequate Hub Wall Steel Sprockets	
															Setscrew Over Key	Setscrew not over key
6	75	45/64	7/16	16	935	3 63/64	2 11/16	26	1165	7 13/64	5 7/16					
7	175	1 3/64	5/8	17	985	4 5/16	2 13/16	27	1170	6 33/64	5 1/2					
8	280	1 3/8	7/8	18	1020	4 41/64	3 1/8	28	1170	7 27/32	5 13/16					
9	385	1 23/32	1 3/16	19	1060	4 61/64	3 1/4	29	1165	8 5/32	6 1/8	15/16 - 1 1/4	1/4 x 1/8	1/4	3/4	1/2
10	485	2 3/64	1 1/4	20	1090	5 9/32	3 1/2	30	1160	8 31/64	6 7/16	15/16 - 1 3/8	5/16 x 5/32	5/16	15/16	5/8
11	580	2 3/8	1 5/8	21	1110	5 19/32	3 3/4	31	1155	8 51/64	6 1/2	17/16 - 1 3/4	3/8 x 3/16	3/8	1 1/8	3/4
12	670	2 45/64	1 3/4	22	1130	5 59/64	3 7/8	32	1143	9 7/64	6 9/16	113/16 - 2 1/4	1/2 x 1/4	1/2	1 1/2	1
13	750	3 1/64	2	23	1150	6 15/64	4 3/16	35	1110	10 5/64	7 1/2	25/16 - 2 3/4	5/8 x 5/16	5/8	1 7/8	1 1/4
14	820	3 11/32	2 1/4	24	1160	6 9/16	4 13/16	40	1020	11 43/64	8 5/8	2 13/16 - 3 1/4	3/4 x 3/8	3/4	2 1/4	1 1/2
15	880	3 43/64	2 3/8	25	1160	6 7/8	5 1/8	45	920	13 17/64	9 3/4	3 5/16 - 3 3/4	7/8 x 7/16	3/4	2 3/8	1 3/4

American Standard No. 100

American Standard No. 100												Std. Keyway (Am. Std.) and Setscrew				
No. of Teeth	Max RPM	Max Hub	Max Bore	No. of Teeth	Max RPM	Max Hub	Max Bore	No. of Teeth	Max RPM	Max Hub	Max Bore	Diameter of Shaft	Keyway Width x Depth	Dia. of Set-Screw	Min. Added To Bore For Adequate Hub Wall Steel Sprockets	
															Setscrew Over Key	Setscrew not over key
6	55	7/8	9/16	16	670	5	3 1/4	26	830	9 1/64	6 1/2					
7	125	1 5/16	7/8	17	700	5 13/32	3 5/8	27	835	9 13/32	6 7/8					
8	200	1 47/64	1 3/16	18	730	5 51/64	3 3/4	28	830	9 13/16	75/16					
9	275	2 9/64	1 3/8	19	755	6 13/64	4 3/16	29	830	10 13/64	7 1/2	15/16 - 1 3/8	5/16 x 5/32	5/16	15/16	5/8
10	350	2 9/16	1 3/4	20	775	6 39/64	4 13/64	30	825	10 39/64	7 9/16	1 7/16 - 1 3/4	3/8 x 3/16	3/8	1 1/8	3/4
11	415	2 31/32	1 15/16	21	790	7	5 1/4	31	820	11	8	1 13/16 - 2 1/4	1/2 x 1/4	1/2	1 1/2	1
12	475	3 3/8	2 1/4	22	805	7 13/32	5 1/2	32	815	11 13/32	8 3/8	2 5/16 - 2 3/4	5/8 x 5/16	5/8	1 7/8	1 1/4
13	535	3 25/32	2 1/2	23	815	7 13/16	5 13/16	35	790	12 39/64	9 1/16	2 13/16 - 3 1/4	3/4 x 3/8	3/4	2 1/4	1 1/2
14	585	4 3/16	2 3/4	24	825	8 13/64	6 3/16	40	730	14 19/32	3 5/16 - 3 3/4	7/8 x 7/16	3/4	2 3/8	1 3/4
15	630	4 19/32	3 1/16	25	830	8 39/64	6 1/2	45	655	16 19/32	3 13/16 - 4 1/2	1 x 1/2	3/4	2 1/2	2

American Standard No. 120

American Standard No. 120												Std. Keyway (Am. Std.) and Setscrew				
No. of Teeth	Max RPM	Max Hub	Max Bore	No. of Teeth	Max RPM	Max Hub	Max Bore	No. of Teeth	Max RPM	Max Hub	Max Bore	Diameter of Shaft	Keyway Width x Depth	Dia. of Set-Screw	Min. Added To Bore For Adequate Hub Wall Steel Sprockets	
															Setscrew Over Key	Setscrew not over key
6	40	1 1/16	11/16	16	520	6	4	26	650	10 1 3/16	7 13/64					
7	100	1 37/64	1 1/16	17	550	6 31/64	4 7/16	27	650	11 1 9/64	8 1/4					
8	155	2 5/64	1 5/16	18	570	6 31/32	5 3/16	28	650	11 2 5/32	8 3/8	1 7/16 - 1 3/4	3/8 x 3/16	3/8	1 1/8	3/4
9	215	2 37/64	1 3/4	19	590	7 29/64	5 1/2	29	650	12 1/4	8 15/16	1 13/16 - 2 1/4	1/2 x 1/4	1/2	1 1/2	1
10	270	3 5/64	2 1/16	20	605	7 15/16	5 15/16	30	645	12 4 7/64	9 3/16	2 5/16 - 2 3/4	5/8 x 5/16	5/8	1 7/8	1 1/4
11	325	3 37/64	2 5/16	21	620	8 27/64	6 3/8	31	645	13 7/32	9 11/16	2 13/16 - 3 1/4	3/4 x 3/8	3/4	2 1/4	1 1/2
12	375	4 1/16	2 3/4	22	630	8 57/64	6 1/2	32	640	13 11/16	10 3/16	3 5/16 - 3 3/4	7/8 x 7/16	3/4	2 3/8	1 3/4
13	415	4 35/64	3	23	640	9 3/8	6 7/8	35	615	15 1/8	3 13/16 - 4 1/2	1 x 1/2	3/4	2 1/2	2
14	455	5 1/32	3 1/4	24	645	9 55/64	7 5/16	40	570	17 33/64	4 9/16 - 5 1/2	1 1/4 x 5/8	3/4	2 3/8	1 3/4
15	490	5 33/64	3 3/4	25	650	10 11/32	7 1/2	45	515	19 5 9/64					

American Standard No. 140

American Standard No. 140												Std. Keyway (Am. Std.) and Setscrew				
No. of Teeth	Max RPM	Max Hub	Max Bore	No. of Teeth	Max RPM	Max Hub	Max Bore	No. of Teeth	Max RPM	Max Hub	Max Bore	Diameter of Shaft	Keyway Width x Depth	Dia. of Set-Screw	Min. Added To Bore For Adequate Hub Wall Steel Sprockets	
															Setscrew Over Key	Setscrew not over key
6	30	1 1/4	7/8	16	380	7 1/64	5 1/4	26	475	12 5/8	9 1/8					
7	70	1 27/32	1 1/4	17	400	7 37/64	5 9/16	27	475	13 3/16	9 11/16	1 7/16 - 1 3/4	3/8 x 3/16	3/8	1 1/8	3/4
8	115	2 7/16	1 11/16	18	415	8 9/64	6 1/8	28	475	13 3/4	10 1/4	1 13/16 - 2 1/4	1/2 x 1/4	1/2	1 1/2	1
9	150	3 1/64	2	19	430	8 45/64	6 1/2	29	475	14 19/64	10 3/4	2 5/16 - 2 3/4	5/8 x 5/16	5/8	1 7/8	1 1/4
10	200	3 19/32	2 5/16	20	440	9 17/64	6 3/4	30	470	14 55/64	2 15/16 - 3 1/4	3/4 x 3/8	3/4	2 1/4	1 1/2
11	235	4 11/64	2 3/4	21	450	9 53/64	7 5/16	31	470	15 27/64	3 5/16 - 3 3/4	7/8 x 7/16	3/4	2 3/8	1 3/4
12	270	4 3/4	3 1/4	22	460	1 025/64	7 1/2	32	465	15 63/64	3 15/16 - 4 1/2	1 x 1/2	3/4	2 1/2	2
13	305	5 5/16	3 9/16	23	465	1 015/16	7 15/16	35	450	17 21/32	4 9/16 - 5 1/2	1 1/4 x 5/8	3/4	2 3/8	1 3/4
14	335	5 7/8	3 7/8	24	470	11 1/2	8 1/2	40	415	20 29/64					
15	360	6 29/64	4 7/16	25	475	12 1/16	8 15/16	45	375	23 15/64					

American Standard No. 160

American Standard No. 160												Std. Keyway (Am. Std.) and Setscrew				
No. of Teeth	Max RPM	Max Hub	Max Bore	No. of Teeth	Max RPM	Max Hub	Max Bore	No. of Teeth	Max RPM	Max Hub	Max Bore	Diameter of Shaft	Keyway Width x Depth	Dia. of Set-Screw	Min. Added To Bore For Adequate Hub Wall Steel Sprockets	
															Setscrew Over Key	Setscrew not over key
6	25	1 27/64	7/8	16	325	8 1/64	6	26	405	14 7/16	10 15/16					
7	60	2 7/64	1 3/8	17	340	8 21/32	6 1/2	27	405	15 5/64	1 3/16 - 2 1/4	1/2 x 1/4	1/2	1 1/2	1
8	100	2 51/64	1 3/4	18	355	9 5/16	6 13/16	28	405	15 23/32	2 5/16 - 2 3/4	5/8 x 5/16	5/8	1 7/8	1 1/4
9	135	3 29/64	2 1/4	19	365	9 61/64	7 7/16	29	400	16 23/64	2 13/16 - 3 1/4	3/4 x 3/8	3/4	2 1/4	1 1/2
10	170	4 1/8	2 3/4	20	375	10 19/32	7 9/16	30	400	17	3 5/16 - 3 3/4	7/8 x 7/16	3/4	2 3/8	1 3/4
11	200	4 25/32	3 1/4	21	385	11 15/64	8 3/16	31	400	17 5/8	4 9/16 - 5 1/2	1 x 1/2	3/4	2 1/2	2
12	230	5 27/64	3 5/8	22	390	11 7/8	8 7/8	32	395	18 17/64					
13	260	6 5/64	4 1/16	23	395	12 33/64	9	35	380	20 3/16					
14	280	6 22/32	4 15/16	24	400	13 5/32	9 5/8	40	355	23 3/8					
15	305	7 3/8	5 1/2	25	400	13 51/64	10 1/4	45	320	26 9/16					

American Standard No. 200

American Standard No. 200												Std. Keyway (Am. Std.) and Setscrew				
No. of Teeth	Max RPM	Max Hub	Max Bore	No. of Teeth	Max RPM	Max Hub	Max Bore	No. of Teeth	Max RPM	Max Hub	Max Bore	Diameter of Shaft	Keyway Width x Depth	Dia. of Set-Screw	Min. Added To Bore For Adequate Hub Wall Steel Sprockets	
															Setscrew Over Key	Setscrew not over key
6	20	1 51/64	1 1/4	16	235	10 1/32	7 1/2	26	290	18 3/64					
7	45	2 21/32	1 7/8	17	245	10 27/32	7 13/16	27	290	18 55/64	2 5/16 - 2 3/4	5/8 x 5/16	5/8	1 7/8	1 1/4
8	70	3 1/2	2 1/4	18	255	11 41/64	8 5/8	28	290	19 21/32	2 13/16 - 3 1/4	3/4 x 3/8	3/4	2 1/4	1 1/2
9	95	4 21/64	2 3/16	19	265	12 7/16	8 15/16	29	290	20 29/64	3 5/16 - 3 3/4	7/8 x 7/16	3/4	2 3/8	1 3/4
10	120	5 5/32	3 3/8	20	270	13 1/4	9 3/4	30	290	21 1/4	4 9/16 - 5 1/2	1 1/4 x 5/8	3/4	2 3/8	1 3/4
11	145	5 63/64	3 15/16	21	280	14 3/64	10 1/2	31	400	22 3/64	5 9/16 - 6 1/2	1 1/2 x 3/4	3/4	3	2
12	165	6 51/64	5	22	280	14 27/32	32	285	22 27/32					
13	185	7 39/64	5 9/16	23	285	15 21/32	35	275	25 15/64					
14	205	8 27/64	6 3/8	24	290	16 29/64	40	255	29 15/64					
15	220	9 7/32	6 1/2	25	290	17 1/4	45	230	33 7/32					

Application Data and Selection Procedure

How to Check Horsepower Rating of Installed Drive

1. Determine the types of driving and driven loads and obtain the proper service factor, as explained in Steps 1 and 2 under Selection Procedures.
2. Selection Procedures.
3. Find the multiple strand factor, for the number of chain strands in the drive, from the Multiple Strand Factor Table, in Horsepower Tables (Page E-186 thru E-192).
4. From the horsepower rating table for the chain pitch, read the figure under the RPM of the small sprocket and to the right of the column giving number of teeth in the small sprocket.
5. The horsepower this drive can properly transmit is as follows:

$$\text{Horsepower Drive Can Transmit} = \frac{\left(\begin{array}{c} \text{Rating Table} \\ \text{Horsepower} \end{array} \right) \times \left(\begin{array}{c} \text{Multiple} \\ \text{Strand} \end{array} \right)}{\text{Service Factor}}$$

Center Distance

The following general principals should be applied in determining shaft center distances. The center distance must always be greater than one-half the sum of the sprocket outside diameters to avoid interference of teeth. When the speed ratio is greater than 3 to 1, the center distance should be not less than the sum of the sprocket diameters. Chain wrap should be at least 120° of the small sprocket — one-third of the teeth meshing.

Longer center distances give greater chain wrap. For average applications a center distance of 30 to 50 pitches of chain is recommended for best results. For pulsating loads, a center distance of 20 to 30 pitches may be desirable. For center distances of 80 pitches or greater, idlers or chain guides should be used to support the chain. Slightly adjustable center distances will provide chain tension as the chain elongates with wear.

Alignment

Accurate alignment of shafts and sprocket tooth faces provide uniform distribution of the load across the entire chain width and contributes substantially to optimum drive life. Shafting, bearings, and foundations should be suitable to maintain the initial alignment. Periodic maintenance should include an inspection of alignment to insure optimum chain life.

Design Horsepower

When making drive selections consideration is given to the loads imposed on the chain. Service factors based on the type of equipment to be driven (Table I, Page E162) and the type of input power (Table II, Page E162) are used to compensate for these loads.

Horsepower Rating Tables

The horsepower ratings in this catalog apply to lubricated single pitch, single strand precision roller chains, both standard and double pitch roller chain.

The ratings reflect a service factor of 1, a chain length of approximately 100 pitches, use of recommended lubrication methods, and a drive arrangement where two aligned sprockets are mounted on parallel horizontal shafts.

The horsepower ratings relate to the speed of the smaller sprocket and drive selections are made on this basis, whether the drive is speed reducing or speed increasing.

For ratings of multiple strand roller chains refer to Multiple Strand Factor in Horsepower Tables.

Lubrication

It has been shown that a separate wedge of fluid lubricant is formed in operating chain joints much like that formed in journal bearings. Therefore, fluid lubricant must be applied to assure an oil supply to the joints and minimize metal to metal contact. Lubrication, if supplied in sufficient volume, also provides effective cooling and impact damping at the higher speeds. For this reason, it is important that the lubrication recommendations be followed. The horsepower rating tables shown throughout this catalog, apply only to drives lubricated in the manner specified in the tables.

Chain drives should be protected against dirt and moisture and the oil supply kept free of contamination. Periodic oil change is desirable. A good grade of non-detergent petroleum base oil is recommended. Heavy oils and grease are generally too stiff to enter and fill the chain joints.

Application Data and Selection Procedure

Types of Lubrication

There are four basic types of lubrication for chain drives. The recommended type shown in the horsepower rating tables is influenced by chain speed and the amount of power transmitted. These are minimum lubrication requirements and the use of a better type (for example, Type C instead of Type B) is acceptable and may be beneficial. Chain life can vary appreciably depending upon the way the drive is lubricated. The better the lubrication, the longer the chain and sprocket life. For this reason, it is important that the lubrication recommendations be followed when using the rating tables given in this catalog.

Lubrication

- TYPE A** — Manual Lubrication. Oil applied periodically with brush or spout can.
- TYPE B** — Oil Bath or Oil Slinger. Oil level maintained in casing at predetermined height.
- TYPE C** — Oil Stream. Oil supplied by circulating pump inside chain loop on lower span.

NOTE: Drip Lubrication. Oil applied between link plate edges from a drip lubricator and should be used in clean environments only.

Selection of Roller Chain Drives

The following information is necessary for the proper selection and design of roller chain drives:

1. Type of input horsepower (electrical motor, internal combustion engine.)
2. Type of equipment to be driven.
3. Horsepower to be transmitted.
4. Full load speed of the fastest running shaft. (RPM)
5. Desired speed of the slow speed shaft. (RPM)
6. Diameters of the driving and driven shafts.
7. Center to center distance of shafts.
8. Position of drive and space limitations.
9. Method of lubrication.
10. Conditions of drive, steady or fluctuating load, hours of operation, lubrication.

Most roller chain drive applications allow considerable latitude in the selection of sprocket sizes and chain pitch, although usually one combination will best fulfill the requirements of power, speed, space limitations and economy.

Chain and Sprocket Selection Procedure Steps:

1. Determine class of driven load.
2. Select service factor.
3. Calculate design horsepower.
4. Select chain pitch.
5. Select number of teeth in small sprocket.
6. Determine number of teeth in larger sprocket.
7. Determine center distance.
8. Calculate chain length.

Drive Positions

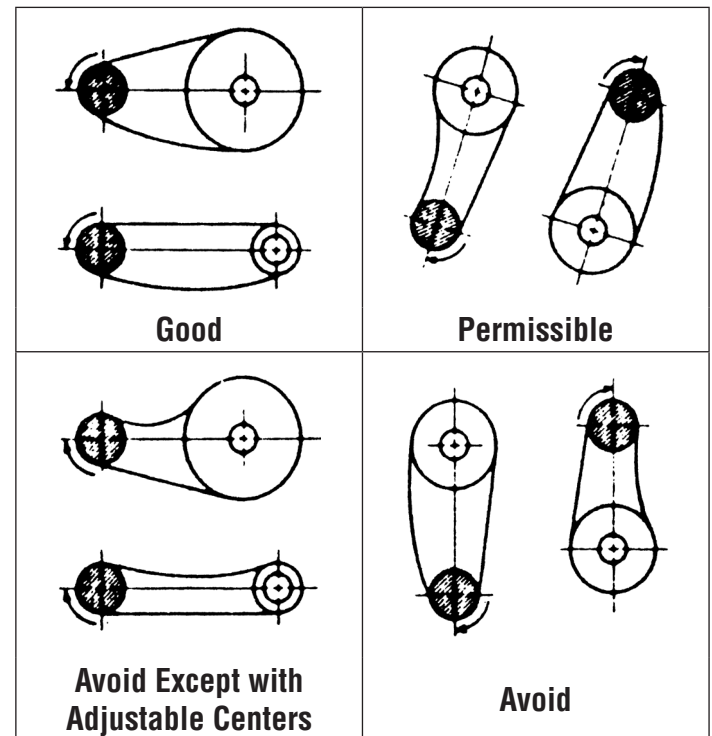

Application Data and Selection Procedure

Step I

Service Classification — Table I

Uniform Load	
<ul style="list-style-type: none"> • Agitators, Liquid • Blowers, Centrifugal • Conveyors, Even Load • Elevators, Even Load • Fans, Centrifugal 	<ul style="list-style-type: none"> • Generators • Line Shafts, Even Load • Machines, Even Load, Non-reversing • Pumps, Centrifugal
Moderate Shock Load	
<ul style="list-style-type: none"> • Moderate Shock Load • Beaters • Compressors, Centrifugal • Conveyors, Uneven Load • Elevators, Uneven Load • Grinders, Pulp • Kilns and Dryers 	<ul style="list-style-type: none"> • Laundry - Washers and Tumblers • Line Shafts, Uneven Load • Machines, Pulsating Load, Non-reversing • Pumps, Reciprocating, Triplex • Screens, Rotary, Even Load • Woodworking Machinery
Heavy Shock Load	
<ul style="list-style-type: none"> • Brick Machines • Compressors Reciprocating • Crushers • Machines, Reversing or Impact Loads 	<ul style="list-style-type: none"> • Mills, Hammer, Rolling or Drawing • Presses • Pumps, Reciprocating, Simplex or Duplex

Step II

Service Factor — Table II

Service Classification	Type of Input Power		
	Internal Combustion Engine with Hydraulic Drive	Electric Motor or Turbine	Internal Combustion Engine with Mechanical Drive
Uniform Load	1.0	1.0	1.2
Moderate Shock Load	1.2	1.3	1.4
Heavy Shock Load	1.4	1.5	1.7

Unfavorable Operating Conditions which may be present should be compensated for by adding .2 to the Service Factor for each unfavorable condition. Some of these conditions are listed below:

1. Multiple Shafts — add .2 for each additional shaft.
2. Excessive speed ratios — exceeding 7 to 1.
3. Heavy starting loads with frequent starts and stops.
4. Conditions of high temperatures, unusually abrasive conditions, or circumstances decreasing lubrication effectiveness or not allowing the use of recommended lubrication procedures.

Step III

Determination of Design Horsepower

Determine the design horsepower of the required drive using the following procedure.

1. Determine Service Classification — Table I. Unlisted equipment may be classified by its similarity to a listed type.
2. Using Service Classification and Frequency of Service, select the Service Factor — Table II. Increase the Service Factor by adding compensation for unfavorable operating conditions.
3. Multiply the normal operating horsepower of the drive by the Compensated Service Factor to obtain Service Horsepower.

Step IV

Drive Selection

Using Design Horsepower computed above, use Trial Selection Chart (Horsepower Tables) on page E184-E185, or enter tables of Horsepower Ratings shown on pages E186 thru E192. Select the smallest pitch chain which has the required horsepower rating for a pinion sprocket turning at the specified RPM. Check to be certain the selected sprocket has a listed maximum bore large enough to accommodate the specified shaft. The tables on pages E-158 thru E-159 gives maximum bores for the usual range of driving sprockets.

If the Design Horsepower at the required RPM is greater than the horsepower rating of the largest pitch chain which can operate at that speed, a multiple chain drive should be considered for the application.

Selection of drives to operate at speeds somewhat below the maximum rating will increase the life of the drive and quietness of operation.

Step V

Driving Sprocket

In selecting the driving sprocket **17 teeth are recommended as a minimum** although 15 teeth are quite often used, and as low as 7 teeth can be cut. When the maximum bore of the 17 tooth sprocket will not accommodate the driving shaft, it is necessary to go to a sprocket with a greater number of teeth. Hardened teeth are recommended for sprockets with 25 teeth or less.

Application Data and Selection Procedure

Step VI

Driven Sprocket (Ratio)

The number of teeth selected for the driven sprocket depends upon the driving sprocket chosen and the desired speed of the driven shaft. When space limitations are a factor, the diameter of the driven sprocket sometimes determines the final selection of drive.

The recommended maximum speed ratio is 7 to 1, although higher ratios are occasionally used. It is usually better design, however, for large reductions to use a double reduction drive.

Select the driven sprocket size from the Speed Ratio Table on page E-170 using the required speed ratio and size of driver sprocket.

Step VII

Shaft Centers

May be calculated from the formula on page E-168 where the sprocket diameters and chain length are known.

On many applications the motor base is adjustable, allowing for slight changes in shaft centers. On long centers some form of chain adjuster or take-up is recommended.

Step VIII

Chain Length

On page E-168 is shown a simple method of computing the length of chain necessary for a drive with given sprocket dimensions and center to center distance of shafts. (See chart on page E-169 for length in ft.)

Chain Drive Design Example

To select a roller chain drive from a 10 HP electric motor (1.625" shaft) 1200 RPM (1150 under load) to a wood working machine shaft at 300 RPM on 30" centers. Drive conditions — moderate pulsating load, good lubrication, 10 hour day operation.

1. Service class — moderate shock load (Table I).
2. Service factor — 1.3 (Table II).
3. Design HP — $1.3 \times 10 = 13$ DHP.
4. Selection — The Horsepower Ratings on page E-184 show that either of the following combinations may be used.

No. D40-19 Tooth — Smoothest in operation

No. 50-18 Tooth — Lower drive cost

For our purpose we select No. 50 chain and checking the bore find that the 1.625" shaft can be accommodated with a stock bored to size sprocket.

The driven sprocket is found as follows:

$$\begin{array}{l} \text{No. Teeth} \\ \text{Driven Sprocket} \end{array} = 18 \times \frac{1150}{300} \text{ (Ratio)} = 68.99 \text{ or } 69 \text{ Teeth}$$

Since 69 teeth is not a stock size we select 70 teeth. The chain length is calculated as shown on page E-169 and is 142 pitches.

Overhung Load

When a sprocket is mounted on a reducer shaft, a calculation should be made to determine the overhung load in pounds using formula on page *i-2* in general engineering section.

Engineering Data & Design

Horsepower equals 33,000 foot pounds per minute, or 550 foot pounds per second. In terms of chain load and speed.

$$HP = \frac{\text{Working Load} \times \text{Ft. Per Min.}}{33,000}$$

$$\text{or } HP = \frac{\text{Working Load} \times T \times P \times \text{RPM}}{396,000}$$

Where T = number of sprocket teeth

P = chain pitch

Chain Working Load when the horsepower input is known and the chain working load is desired, this can be calculated as follows:

$$\text{Working Load} = \frac{HP \times 33,000}{\text{Ft. Per Min.}}$$

$$\text{or } = \frac{HP \times 396,000}{T \times P \times \text{RPM}}$$

Chain Speed can be determined from the following formula:

$$\text{Chain Speed (Ft. Per Min.)} = \frac{T \times \text{RPM}}{K}$$

Where T = number of sprocket teeth

Constant K (Pitches of Chain Per Foot)

PITCH	3/8"	1/2"	5/8"	3/4"	1"	1 1/4"	1 1/2"	1 3/4"	2"	2 1/2"	3"
K	32	24	19.2	16	12	9.6	8	6.85	6	4.8	4

Approx. Wt./Ft. of Standard Roller Chain

Number	Single	Double	Triple	Quadruple
25	0.08	0.18	0.27	0.35
35	0.23	0.46	0.69	0.92
41	0.28	—	—	—
40	0.41	0.82	1.23	1.64
50	0.69	1.38	2.07	2.76
60	1.04	2.08	3.12	4.16
80	1.77	3.54	5.31	7.08
100	2.59	5.18	7.77	10.36
120	4.05	8.10	12.15	16.20
140	5.10	10.20	15.30	20.40
160	6.85	13.70	20.55	27.40
180	9.30	18.20	27.20	36.30
200	10.20	21.00	31.50	42.00
240	16.90	33.40	50.00	66.50

Factor of Safety is determined as follows:

$$FS = \frac{\text{Chain Ultimate Strength}}{\text{Chain Working Load}}$$

Shaft Torque ordinarily is greater for the driven shaft than for the driving shaft due to the difference in sprocket sizes and RPM Torque is usually expressed in inch pounds.

$$\text{Torque (Driving Shaft)} = \frac{HP \times 63,000}{\text{RPM}}$$

$$\text{Torque (Driven Shaft)} = \frac{\text{Working Load} \times R}{P}$$

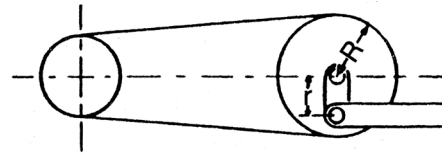

Where a crank arm is used the load transmitted by the arm can be determined as follows:

$$\text{Crank Arm Load} = \frac{\text{Driven Shaft Torque}}{r}$$

$$\text{or } = \frac{\text{Chain Working Load} \times R}{r}$$

Catenary Tension imposed by reason of the weight of chain can be approximated as follows:

$$\text{Catenary Tension} = \frac{W \times L}{8 \times S} + (W \times S)$$

Where W = weight of chain (lbs. per ft.)

S = chain sag (feet) = 2% to 3% of shaft centers approx.

L = Shaft center in feet.

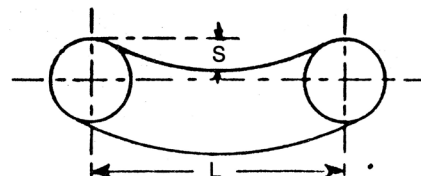

Engineering Data & Design

Conveyor Chains

Chains used in the design of conveyors should be selected on the basis of the **chain pull** imposed by the application and the permissible or **maximum working load** of the chain.

In some instances a larger pitch chain than is necessary may be selected due to the desired attachment spacing, and the effect in this case would be to increase the life of the conveyor.

Horizontal Conveyors

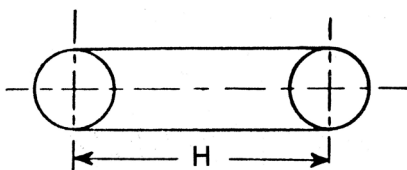

$$\text{Total pull of chains} = f H (W + P)$$

NOTE: When lower strand of conveyor drags on runway above formula becomes $f H (W + 2P)$.

Vertical Conveyors

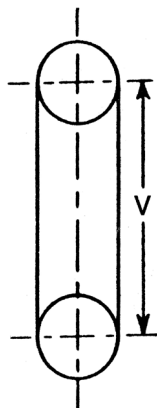

$$\text{Total pull of chains} = V (W + P)$$

- H (ft) = Horizontal projection of conveyor length.
- V (ft) = Vertical projection of conveyor length.
- W (lb) = Weight of material handled per foot of conveyor length.
- P (lb) = Weight per foot of all moving conveyor parts (single or two strand).
- f = Coefficient of friction of chain on runway.

Chain Pull

The force or pull required to move a conveyor includes the pull necessary to move the weight of chain and material and the frictional resistance of the chain parts on the runways. The following formulas may be used in calculating the total chain pull. The same formula applies in the case of single or parallel strand chain conveyors, but in the case of parallel strand conveyors, the pull per chain is one-half of the figure calculated from the formula.

Inclined Conveyors

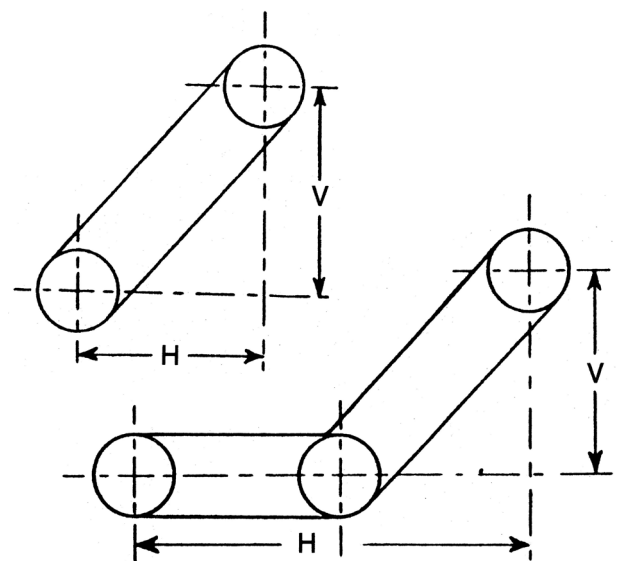

$$\text{Total pull of chains} = f H (W + P) + V (W + P)$$

NOTE: When lower strand of conveyor drags on runway the factor P (f H - V) should be added to above formula unless V is greater than f H.

Value of Coefficient F

Sliding steel on iron or steel	25%
Rolling friction	15%

(If material or other than the usual chain parts are in contact with the runway, the coefficient should be increased to compensate for the added resistance.)

Chain Drive Selection

Step 1:

Prime Driver:	_____	_____	_____
	Type & Description	Rated - HP	RPM
Driven Comp:	_____	_____	_____
	Type & Description	RPM	Hours/Day
Center Distance:	_____ "	_____ "	_____ "
	Maximum	Minimum	Nominal

Step 2:

_____ Service Classification (Step I Page E-162)

Step 3:

_____ Service Factor (Include additions to basic factor)
(Step II Page E-162)

Step 4: Determine Design HP

_____ HP × _____ Service Factor = _____ HP Design

Step 5: Speed Ratio

_____ RPM Faster Shaft × _____ RPM Slower Shaft = _____ Ratio (E-172)

Step 6: From selector chart, select proper chain pitch & driver sprocket. (Check Martin Catalog page E-184.)

A. _____ Chain Pitch B. _____ Driver Sprocket C. _____ Maximum Bore
(Pages E-16 thru E-112)

Step 7: From ratio chart, select proper driven sprocket.

C. _____ Driven Sprocket _____ Maximum Bore

Step 8: Check manufacturer's catalog for maximum bore recommended & final stock selection. (Pages E-16 thru E-112)

Step 9: Review Horsepower table for type of lubrication required.

OR Type: A B C (Pages E-161 and E-186 thru E-192)
Type: 1 2 3 (Pages E-191 and E-192)

Step 10:

_____ Center Dist. (inches) ÷ _____ Chain Pitch = _____ Center Dist. (pitches)

Step 11: Formula for chain length = $2C + \frac{N+n}{2} + \frac{A}{C}$

Where: C = Center Dist. in pitches
N = Number of teeth in Driven Sprocket
n = Number of teeth in Driver Sprocket
A = Value from table tabulated for N - n values

Brinell, Rockwell and Scleroscope Hardness Numbers with Corresponding Tensile Strength

Brinell 10 MM Ball 3,000 Kg.	Rockwell "C" 120 Cone 150 Kg.	Scleroscope Shore Model C	Tensile Strength 1000 Lb. Per Sq. In.
745	68	100	368
712	66	95	352
682	64	91	337
653	62	87	324
627	60	84	311
601	58	81	298
578	57	78	287
555	55	75	276
534	53	72	266
514	52	70	256
495	50	67	247
477	49	65	238
461	47	63	229
444	46	61	220
429	45	59	212
415	44	57	204
401	42	55	196
388	41	54	189
375	40	52	182
362	38	51	176
351	37	49	170
341	36	48	165
331	35	46	160
321	34	45	155
311	33	44	150
302	32	43	146
293	31	42	142
285	30	40	138
277	29	39	134
269	28	38	131
262	26	37	128
255	25	37	125
248	24	36	122
241	23	35	119
235	22	34	116
229	21	33	113
223	20	32	110
	Rockwell "B" 1/16" Ball 100 Kg.		
217	97	31	107
212	96	31	104
207	95	30	101
202	94	30	99
197	93	29	97
192	92	28	95
187	91	28	93
183	90	27	91
179	89	27	89
174	88	26	87

Note: Hardening cannot be accurately checked with a file — stationary or portable hardness testers should be used for conclusive results.

Material

All Martin stock sprockets are made of quality steel poured to our specifications.

Bar size sprockets normally include sizes up to 7" or 7 1/2" in diameter type "B", "BS", "QD", "TB" single, double & triple width. And can easily be electrical induction or flame hardened — to Rockwell "C" 40 to 50.

Plate sprockets normally include sizes 7 1/2" in diameter and larger type "B", "BS", "C", "QD", "TB" single, double, & triple width fabricated and type "A" all diameters. This material would have 35 to 40 points of carbon and can be induction or flame hardened to Rockwell "C" 30 to 45. Degree of hardness obtainable and method depends on size of sprocket.

Special quality steel can be used for large quantities or made-to-order sprockets if specified.

Hardening Recommendations

Hardened teeth substantially increases sprocket life and is recommended under conditions listed below:

1. Pinion or driver where the reduction is 4:1 or greater.
2. Slow speed drives (100 FPM or less).
3. Where safety factor is less than standard.
4. Unusual abrasive conditions.

Degree of hardness — this is governed by conditions prevailing each application — for stock sprockets these general suggestions may be used as guide lines:

1. Rockwell "C" 35 to 50 pinion or driver.
2. Rockwell "C" 25 to 40 larger diameter or driver sprockets.

Induction or flame hardening will be used as best suited to the individual application. The diameter and pitch of the sprocket govern the method used.

Caution should be used to avoid "file hardness" (Rockwell C 62 and above) as it is not recommended for sprockets due to brittleness.

Depth of hardening should be limited so as to provide case only on the wear surfaces with a tough resilient core to absorb shock — (see illustration tooth section).

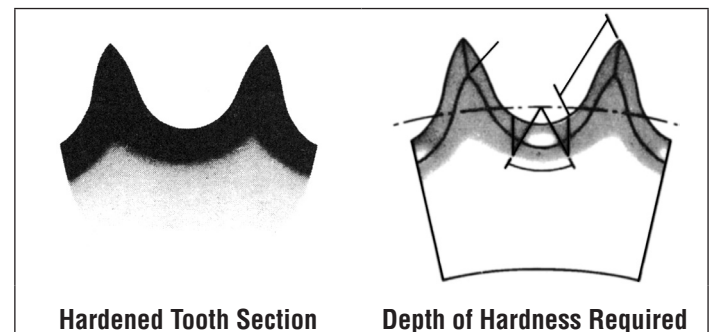

Chain Length Calculation

The following equation may be used to determine the chain length required for any two-sprocket drive.

$$L = 2C + \frac{N + n}{2} + \frac{.1013 (N - n)^2}{4C} \quad \text{or substituting A for } \frac{.1013 (N - n)^2}{4C}, \quad L = 2C + \frac{N + n}{2} + \frac{A}{C}$$

Where:

- C = Shaft Center Distance in pitches
- L = Length of chain in pitches
- N = Number of teeth in larger sprocket
- n = Number of teeth in smaller sprocket
- $\pi = 3.1416$
- A = Value from table below tabulated for values of N-n
- P = Pitch of chain

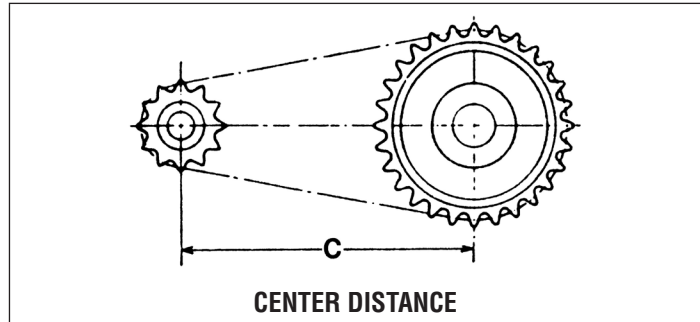

NOTE: The method described with above table of constants is sufficiently accurate for practically all commercial chain drives. When, however, a high degree of precision is necessary, especially if the drive is vertical, the following formula is useful in determining the exact centers for chain length already determined.

Calculation of shaft centers

The following formula is useful in determining the approximate centers in inches for chain lengths in pitches already determined.

$$C = \frac{P}{8} \left\{ 2L - N - n + \sqrt{(2L - N - n)^2 - 0.810 (N - n)^2} \right\}$$

Values of A For Chain Length Calculation

N - n	A	N - n	A	N - n	A	N - n	A	N - n	A	N - n	A
1	0.03	32	25.94	63	100.54	94	223.82	125	395.79	156	616.44
2	0.10	33	27.58	64	103.75	95	228.61	126	402.14	157	624.37
3	0.23	34	29.28	65	107.02	96	233.44	127	408.55	158	632.35
4	0.41	35	31.03	66	110.34	97	238.33	128	415.01	159	640.38
5	0.63	36	32.83	67	113.71	98	243.27	129	421.52	160	648.46
6	0.91	37	34.68	68	117.13	99	248.26	130	428.08	161	656.59
7	1.24	38	36.58	69	120.60	100	253.30	131	434.69	162	664.77
8	1.62	39	38.53	70	124.12	101	258.39	132	441.36	163	673.00
9	2.05	40	40.53	71	127.69	102	263.54	133	448.07	164	681.28
10	2.53	41	42.58	72	131.31	103	268.73	134	454.83	165	689.62
11	3.06	42	44.68	73	134.99	104	273.97	135	461.64	166	698.00
12	3.65	43	46.84	74	138.71	105	279.27	136	468.51	167	706.44
13	4.28	44	49.04	75	142.48	106	284.67	137	475.42	168	714.92
14	4.96	45	51.29	76	146.31	107	290.01	138	482.39	169	723.46
15	5.70	46	53.60	77	150.18	108	295.45	139	489.41	170	732.05
16	6.48	47	55.95	78	154.11	109	300.95	140	496.47	171	740.68
17	7.32	48	58.36	79	158.09	110	306.50	141	503.59	172	749.37
18	8.21	49	60.82	80	162.11	111	312.09	142	510.76	173	758.11
19	9.14	50	63.33	81	166.19	112	317.74	143	517.98	174	766.90
20	10.13	51	65.88	82	170.32	113	323.44	144	525.25	175	775.74
21	11.17	52	68.49	83	174.50	114	329.19	145	532.57	176	784.63
22	12.26	53	71.15	84	178.73	115	334.99	146	539.94	177	793.57
23	13.40	54	73.86	85	183.01	116	340.84	147	547.36	178	802.57
24	14.59	55	76.62	86	187.34	117	346.75	148	554.83	179	811.61
25	15.83	56	79.44	87	191.73	118	352.70	149	562.36	180	820.70
26	17.12	57	82.30	88	196.16	119	358.70	150	569.93	181	829.85
27	18.47	58	85.21	89	200.64	120	364.76	151	577.56	182	839.04
28	19.86	59	88.17	90	205.18	121	370.86	152	585.23	183	848.29
29	21.30	60	91.19	91	209.76	122	377.02	153	592.96	184	857.58
30	22.80	61	94.25	92	214.40	123	383.22	154	600.73	185	866.93
31	24.34	62	97.37	93	219.08	124	389.48	155	608.56		



Chain Drive Engineering

Roller Chain Lengths

No. of Pitches	Chain Pitch – Inches										
	3/8	1/2	5/8	3/4	1	1 1/4	1 1/2	1 3/4	2	2 1/2	3
	Chain Length – Feet										
1	0.0313	0.0417	0.0521	0.0625	0.0833	0.1042	0.1250	0.1458	0.1667	0.2083	0.2500
2	0.0625	0.0833	0.1042	0.1250	0.1667	0.2083	0.2500	0.2917	0.3333	0.4167	0.5000
3	0.0938	0.1250	0.1563	0.1875	0.2500	0.3125	0.3750	0.4375	0.5000	0.6250	0.7500
4	0.1250	0.1667	0.2083	0.2500	0.3333	0.4167	0.5000	0.5833	0.6667	0.8333	1.0000
5	0.1563	0.2083	0.2604	0.3125	0.4167	0.5208	0.6250	0.7292	0.8333	1.0417	1.2500
6	0.1875	0.2500	0.3125	0.3750	0.5000	0.6250	0.7500	0.8750	1.0000	1.2500	1.5000
7	0.2188	0.2917	0.3646	0.4375	0.5833	0.7292	0.8750	1.0208	1.1667	1.4583	1.7500
8	0.2500	0.3333	0.4167	0.5000	0.6667	0.8333	1.0000	1.1667	1.3333	1.6667	2.0000
9	0.2813	0.3750	0.4688	0.5625	0.7500	0.9375	1.1250	1.3125	1.5000	1.8750	2.2500
10	0.3125	0.4167	0.5208	0.6250	0.8333	1.0417	1.2500	1.4583	1.6667	2.0833	2.5000
11	0.3438	0.4584	0.5729	0.6875	0.9167	1.1459	1.3750	1.6041	1.8333	2.2917	2.7500
12	0.3750	0.5000	0.6250	0.7500	1.0000	1.2500	1.5000	1.7500	2.0000	2.5000	3.0000
13	0.4063	0.5417	0.6771	0.8125	1.0833	1.3542	1.6250	1.8958	2.1667	2.7083	3.2500
14	0.4375	0.5833	0.7292	0.8750	1.1667	1.4583	1.7500	2.0417	2.3333	2.9167	3.5000
15	0.4688	0.6250	0.7813	0.9375	1.2500	1.5625	1.8750	2.1875	2.5000	3.1250	3.7500
16	0.5000	0.6667	0.8333	1.0000	1.3333	1.6667	2.0000	2.3333	2.6667	3.3333	4.0000
17	0.5313	0.7084	0.8854	1.0625	1.4167	1.7709	2.1250	2.4791	2.8333	3.5417	4.2500
18	0.5625	0.7500	0.9375	1.1250	1.5000	1.8750	2.2500	2.6250	3.0000	3.7500	4.5000
19	0.5938	0.7917	0.9896	1.1875	1.5833	1.9792	2.3750	2.7708	3.1667	3.9583	4.7500
20	0.6250	0.8333	1.0417	1.2500	1.6667	2.0833	2.5000	2.9167	3.3333	4.1667	5.0000
21	0.6563	0.8750	1.0938	1.3125	1.7500	2.1875	2.6250	3.0625	3.5000	4.3750	5.2500
22	0.6875	0.9167	1.1458	1.3750	1.8333	2.2917	2.7500	3.2083	3.6667	4.5833	5.5000
23	0.7188	0.9584	1.1979	1.4375	1.9166	2.3959	2.8750	3.3541	3.8333	4.7917	5.7500
24	0.7500	1.0000	1.2500	1.5000	2.0000	2.5000	3.0000	3.5000	4.0000	5.0000	6.0000
25	0.7813	1.0417	1.3021	1.5625	2.0833	2.6042	3.1250	3.6458	4.1667	5.2083	6.2500
26	0.8125	1.0833	1.3541	1.6250	2.1667	2.7083	3.2500	3.7917	4.3333	5.3167	6.5000
27	0.8438	1.1250	1.4062	1.6875	2.2500	2.8125	3.3750	3.9375	4.5000	5.6250	6.7500
28	0.8750	1.1667	1.4583	1.7500	2.3333	2.9167	3.5000	4.0833	4.6667	5.8333	7.0000
29	0.9063	1.2084	1.5104	1.8125	2.4167	3.0209	3.6250	4.2291	4.8333	6.0417	7.2500
30	0.9375	1.2500	1.5625	1.8750	2.5000	3.1250	3.7500	4.3750	5.0000	6.2500	7.5000
31	0.9688	1.2917	1.6146	1.9375	2.5833	3.2292	3.8750	4.5208	5.1667	6.4583	7.7500
32	1.0000	1.3333	1.6667	2.0000	2.6667	3.3333	4.0000	4.6667	5.3333	6.6667	8.0000
33	1.0313	1.3750	1.7188	2.0625	2.7500	3.4375	4.1250	4.8125	5.5000	6.8750	8.2500
34	1.0625	1.4167	1.7708	2.1250	2.8333	3.5417	4.2500	4.9583	5.6667	7.0833	8.5000
35	1.0938	1.4584	1.8229	2.1875	2.9167	3.6459	4.3750	5.1041	5.8333	7.2917	8.7500
36	1.1250	1.5000	1.8750	2.2500	3.0000	3.7500	4.5000	5.2500	6.0000	7.5000	9.0000
37	1.1563	1.5417	1.9271	2.3125	3.0833	3.8542	4.6250	5.3958	6.1667	7.7083	9.2500
38	1.1875	1.5833	1.9791	2.3750	3.1667	3.9583	4.7500	5.5417	6.3333	7.9167	9.5000
39	1.2188	1.6250	2.0312	2.4375	3.2500	4.0625	4.8750	5.0875	6.5000	8.1250	9.7500
40	1.2500	1.6667	2.0833	2.5000	3.3333	4.1667	5.0000	5.8333	6.6667	8.3333	10.0000
41	1.2813	1.7084	2.1354	2.5625	3.4167	4.2709	5.1250	5.9791	6.8333	8.5417	10.2500
42	1.3125	1.7500	2.1875	2.6250	3.5000	4.3750	5.2500	6.1250	7.0000	8.7500	10.5000
43	1.3438	1.7917	2.2396	2.6875	3.5833	4.4792	5.3750	6.2708	7.1667	8.9583	10.7500
44	1.3750	1.8333	2.2916	2.7500	3.6667	4.5833	5.5000	6.4167	7.3333	9.1667	11.0000
45	1.4063	1.8750	2.3437	2.8125	3.7500	4.6875	5.6250	6.5625	7.5000	9.3750	11.2500
46	1.4375	1.9167	2.3958	2.8750	3.8333	4.7917	5.7500	6.7083	7.6667	9.5833	11.5000
47	1.4688	1.9584	2.4479	2.9375	3.9167	4.8959	5.8750	6.8541	7.8333	9.7917	11.7500
48	1.5000	2.0000	2.5000	3.0000	4.0000	5.0000	6.0000	7.0000	8.0000	10.0000	12.0000
49	1.5313	2.0417	2.5521	3.0625	4.0833	5.1042	6.1250	7.1458	8.1667	10.0283	12.2500
50	1.5625	2.0833	2.6042	3.1250	4.1667	5.2083	6.2500	7.2917	8.3333	10.4167	12.5000
51	1.5938	2.1250	2.6563	3.1875	4.2500	5.3125	6.3750	7.4375	8.5000	10.6250	12.7500
52	1.6250	2.1667	2.7083	3.2500	4.3333	5.4167	6.5000	7.5833	8.6667	10.8333	13.0000
53	1.6563	2.2084	2.7604	3.3125	4.4167	5.5209	6.6250	7.7291	8.8333	11.0417	13.2500
54	1.6875	2.2500	2.8125	3.3750	4.5000	5.6250	6.7500	7.8750	9.0000	11.2500	13.5000
55	1.7188	2.2917	2.8647	3.4375	4.5833	5.7292	6.8750	8.0208	9.1667	11.4583	13.7500
56	1.7500	2.3333	2.9167	3.5000	4.6667	5.8333	7.0000	8.1667	9.3333	11.6667	14.0000
57	1.7813	2.3750	2.9688	3.5625	4.7500	5.9375	7.1250	8.3125	9.5000	11.8750	14.2500
58	1.8125	2.4167	3.0208	3.6250	4.8333	6.0417	7.2500	8.4583	9.6667	12.0833	14.5000
59	1.8438	2.4584	3.0729	3.6875	4.9167	6.1459	7.3750	8.6041	9.8333	12.2917	14.7500
60	1.8750	2.5000	3.1250	3.7500	5.0000	6.2500	7.5000	8.7500	10.0000	12.5000	15.0000
61	1.9063	2.5417	3.1771	3.8125	5.0833	6.3542	7.6250	8.8958	10.1667	12.7083	15.2500
62	1.9375	2.5833	3.2292	3.8750	5.1667	6.4583	7.7500	9.0417	10.3333	12.9167	15.5000
63	1.9688	2.6250	3.2813	3.9375	5.2500	6.5625	7.8750	9.1875	10.5000	13.1250	15.7500
64	2.0000	2.6667	3.3333	4.0000	5.3333	6.6667	8.0000	9.3333	10.6667	13.3333	16.0000
65	2.0313	2.7084	3.3854	4.0625	5.4167	6.7709	8.1250	9.4791	10.8333	13.5417	16.2500
66	2.0625	2.7500	3.4375	4.1250	5.5000	6.8750	8.2500	9.6250	11.0000	13.7500	16.5000
67	2.0938	2.7917	3.4897	4.1875	5.5833	6.9792	8.3750	9.7708	11.1667	13.9583	16.7500
68	2.1250	2.8333	3.5417	4.2500	5.6667	7.0833	8.5000	9.9167	11.3333	14.1667	17.0000
69	2.1563	2.8750	3.5938	4.3125	5.7500	7.1875	8.6250	10.0625	11.5000	14.3750	17.2500
70	2.1875	2.9167	3.6458	4.3750	5.8333	7.2917	8.7500	10.2083	11.6667	14.5833	17.5000
71	2.2188	2.9584	3.6979	4.4375	5.9167	7.3959	8.8750	10.3541	11.8333	14.7917	17.7500
72	2.2500	3.0000	3.7500	4.5000	6.0000	7.5000	9.0000	10.5000	12.0000	15.0000	18.0000
73	2.2813	3.0417	3.8021	4.5625	6.0833	7.6042	9.1250	10.6458	12.1667	15.2083	18.2500
74	2.3125	3.0833	3.8541	4.6250	6.1667	7.7083	9.2500	10.7917	12.3333	15.4167	18.5000
75	2.3438	3.1250	3.9062	4.6875	6.2500	7.8125	9.3750	10.9375	12.5000	15.6250	18.7500
80	2.5000	3.3333	4.1667	5.0000	6.6667	8.3333	10.0000	11.6667	13.3333	16.6667	20.0000
85	2.6563	3.5417	4.4271	5.3125	7.0833	8.8542	10.6250	12.3958	14.1667	17.7083	21.2500
90	2.8125	3.7500	4.6875	5.6250	7.5000	9.3750	11.2500	13.1250	15.0000	18.7500	22.5000
95	2.9688	3.9584	4.9479	5.9375	7.9167	9.8959	11.8750	13.8541	15.8333	19.7917	23.7500
100	3.1250	4.1667	5.2083	6.2500	8.3333	10.4167	12.5000	14.5833	16.6667	20.8333	25.0000



Speed Ratios For Sprocket Combinations Driver Sprocket Teeth

		9	10	11	12	13	14	15	16	17	18	19	20	21	22	23	24	25	26
Driven Sprocket Teeth	9	1.00																	
	10	1.11	1.00																
	11	1.22	1.10	1.00															
	12	1.33	1.20	1.09	1.00														
	13	1.44	1.30	1.18	1.08	1.00													
	14	1.56	1.40	1.27	1.17	1.08	1.00												
	15	1.67	1.50	1.36	1.25	1.15	1.07	1.00											
	16	1.78	1.60	1.45	1.33	1.23	1.14	1.07	1.00										
	17	1.89	1.70	1.55	1.42	1.31	1.21	1.13	1.06	1.00									
	18	2.00	1.80	1.64	1.50	1.38	1.29	1.20	1.13	1.06	1.00								
	19	2.11	1.90	1.73	1.58	1.46	1.36	1.27	1.19	1.12	1.06	1.00							
	20	2.22	2.00	1.82	1.67	1.54	1.43	1.33	1.25	1.18	1.11	1.05	1.00						
	21	2.33	2.10	1.91	1.75	1.61	1.50	1.40	1.31	1.23	1.17	1.10	1.05	1.00					
	22	2.44	2.20	2.00	1.83	1.69	1.57	1.47	1.38	1.29	1.22	1.16	1.10	1.05	1.00				
	23	2.56	2.30	2.09	1.92	1.77	1.64	1.53	1.44	1.35	1.28	1.21	1.15	1.09	1.04	1.00			
	24	2.67	2.40	2.18	2.00	1.85	1.71	1.60	1.50	1.41	1.33	1.26	1.20	1.14	1.09	1.04	1.00		
	25	2.78	2.50	2.27	2.08	1.92	1.79	1.67	1.56	1.47	1.39	1.32	1.25	1.19	1.14	1.09	1.04	1.00	
	26	2.89	2.60	2.36	2.17	2.00	1.86	1.73	1.63	1.53	1.45	1.37	1.30	1.24	1.18	1.13	1.08	1.04	1.00
	27	3.00	2.70	2.45	2.25	2.08	1.93	1.80	1.69	1.59	1.50	1.42	1.35	1.29	1.23	1.17	1.12	1.08	1.04
	28	3.11	2.80	2.54	2.33	2.15	2.00	1.87	1.75	1.65	1.56	1.47	1.40	1.33	1.27	1.22	1.17	1.12	1.08
	29	3.22	2.90	2.64	2.42	2.23	2.07	1.93	1.81	1.71	1.61	1.53	1.45	1.38	1.32	1.26	1.21	1.16	1.12
	30	3.33	3.00	2.73	2.50	2.31	2.14	2.00	1.88	1.76	1.67	1.58	1.50	1.43	1.36	1.31	1.25	1.20	1.15
	31	3.44	3.10	2.82	2.58	2.38	2.21	2.07	1.94	1.82	1.72	1.63	1.55	1.48	1.41	1.35	1.29	1.24	1.19
	32	3.56	3.20	2.91	2.67	2.46	2.28	2.13	2.00	1.88	1.78	1.68	1.60	1.52	1.45	1.39	1.33	1.28	1.23
	33	3.67	3.30	3.00	2.75	2.54	2.36	2.20	2.06	1.94	1.83	1.74	1.65	1.57	1.50	1.43	1.38	1.32	1.27
	34	3.78	3.40	3.09	2.83	2.62	2.43	2.27	2.13	2.00	1.89	1.79	1.70	1.62	1.55	1.48	1.42	1.36	1.31
	35	3.89	3.50	3.18	2.92	2.69	2.50	2.33	2.19	2.06	1.95	1.84	1.75	1.67	1.59	1.52	1.46	1.40	1.34
	36	4.00	3.60	3.27	3.00	2.77	2.57	2.40	2.25	2.12	2.00	1.89	1.80	1.71	1.63	1.57	1.50	1.44	1.38
	37	4.11	3.70	3.36	3.08	2.85	2.64	2.47	2.31	2.18	2.06	1.95	1.85	1.76	1.68	1.61	1.54	1.48	1.42
	38	4.22	3.80	3.45	3.17	2.92	2.71	2.53	2.38	2.24	2.11	2.00	1.90	1.81	1.73	1.65	1.58	1.52	1.46
	39	4.33	3.90	3.55	3.25	3.00	2.79	2.60	2.44	2.29	2.17	2.05	1.95	1.86	1.77	1.70	1.63	1.56	1.50
	40	4.44	4.00	3.64	3.33	3.08	2.86	2.67	2.50	2.35	2.22	2.10	2.00	1.90	1.82	1.74	1.67	1.60	1.54
	41	4.56	4.10	3.73	3.42	3.15	2.93	2.73	2.56	2.41	2.28	2.16	2.05	1.95	1.86	1.78	1.71	1.64	1.58
	42	4.67	4.20	3.82	3.50	3.23	3.00	2.80	2.63	2.47	2.34	2.21	2.10	2.00	1.91	1.83	1.75	1.68	1.61
	43	4.78	4.30	3.91	3.58	3.31	3.07	2.87	2.69	2.53	2.39	2.26	2.15	2.05	1.95	1.87	1.79	1.72	1.65
	44	4.89	4.40	4.00	3.67	3.39	3.14	2.93	2.75	2.59	2.44	2.32	2.20	2.10	2.00	1.91	1.83	1.76	1.69
	45	5.00	4.50	4.09	3.75	3.46	3.21	3.00	2.81	2.65	2.50	2.37	2.25	2.14	2.04	1.96	1.88	1.80	1.73
	46	5.11	4.60	4.18	3.83	3.54	3.29	3.07	2.88	2.71	2.56	2.42	2.30	2.19	2.09	2.00	1.92	1.84	1.77
	47	5.22	4.70	4.27	3.92	3.62	3.36	3.13	2.94	2.76	2.61	2.47	2.35	2.24	2.14	2.04	1.96	1.88	1.81
	48	5.33	4.80	4.36	4.00	3.69	3.43	3.20	3.00	2.82	2.67	2.52	2.40	2.28	2.18	2.09	2.00	1.92	1.84
	49	5.44	4.90	4.45	4.08	3.77	3.50	3.27	3.06	2.88	2.72	2.58	2.45	2.33	2.23	2.13	2.04	1.96	1.88
	50	5.56	5.00	4.55	4.17	3.85	3.57	3.33	3.13	2.94	2.78	2.63	2.50	2.38	2.27	2.17	2.08	2.00	1.92
	51	5.67	5.10	4.64	4.25	3.92	3.64	3.40	3.19	3.00	2.83	2.68	2.55	2.43	2.32	2.22	2.13	2.04	1.96
	52	5.78	5.20	4.73	4.33	4.00	3.71	3.47	3.25	3.06	2.89	2.74	2.60	2.48	2.36	2.26	2.17	2.08	2.00
	53	5.89	5.30	4.82	4.42	4.08	3.79	3.53	3.31	3.12	2.94	2.79	2.65	2.52	2.41	2.30	2.21	2.12	2.04
	54	6.00	5.40	4.91	4.50	4.15	3.86	3.60	3.38	3.18	3.00	2.84	2.70	2.57	2.45	2.35	2.25	2.16	2.07
	55	6.11	5.50	5.00	4.58	4.23	3.93	3.67	3.44	3.24	3.06	2.90	2.75	2.62	2.50	2.39	2.29	2.20	2.12
	56	6.22	5.60	5.09	4.67	4.31	4.00	3.73	3.50	3.29	3.11	2.95	2.80	2.67	2.55	2.43	2.33	2.24	2.15
	57	6.33	5.70	5.18	4.75	4.38	4.07	3.80	3.56	3.35	3.17	3.00	2.85	2.71	2.59	2.48	2.38	2.28	2.19
	58	6.44	5.80	5.27	4.83	4.46	4.14	3.87	3.63	3.41	3.22	3.05	2.90	2.76	2.64	2.52	2.42	2.32	2.23
	59	6.56	5.90	5.36	4.92	4.54	4.21	3.93	3.69	3.47	3.28	3.11	2.95	2.81	2.68	2.57	2.46	2.36	2.27
	60	6.67	6.00	5.45	5.00	4.61	4.28	4.00	3.75	3.53	3.34	3.16	3.00	2.86	2.72	2.61	2.50	2.40	2.30
	68	7.55	6.80	6.18	5.66	5.23	4.86	4.54	4.25	4.00	3.78	3.58	3.40	3.24	3.09	2.96	2.84	2.72	2.61
	70	7.78	7.00	6.36	5.83	5.38	5.00	4.67	4.38	4.12	3.89	3.68	3.50	3.33	3.18	3.05	2.92	2.80	2.69
	72	8.00	7.20	6.54	6.00	5.54	5.14	4.80	4.50	4.24	4.00	3.79	3.60	3.43	3.27	3.13	3.00	2.88	2.77
	76			6.91	6.33	5.84	5.43	5.07	4.75	4.47	4.23	4.00	3.80	3.62	3.45	3.31	3.17	3.04	2.92
	80			7.27	6.66	6.15	5.71	5.34	5.00	4.70	4.45	4.21	4.00	3.81	3.63	3.48	3.34	3.20	3.07
	84				7.00	6.46	6.00	5.60	5.25	4.94	4.67	4.42	4.20	4.00	3.81	3.65	3.50	3.36	3.23
	95					7.31	6.78	6.33	5.94	5.59	5.28	5.00	4.75	4.52	4.32	4.13	3.96	3.80	3.65
	96					7.38	6.85	6.40	6.00	5.64	5.34	5.05	4.80	4.57	4.36	4.18	4.00	3.84	3.69
	102						7.28	6.80	6.38	6.00	5.67	5.37	5.10	4.86	4.63	4.44	4.25	4.08	3.92
	112								7.00	6.59	6.23	5.89	5.60	5.33	5.08	4.87	4.67	4.48	4.30

Martin stock sprockets in pitches No. 40 through No. 100 are available with 8 to 60 teeth inclusive and in all common larger sizes for all pitches.



Sprocket Diameter

No. 25

1/4" Pitch

Roller Chain Sprocket Diameters

No. of Pitches	Pitch Diameter	Outside Diameter	Caliper Diameter	No. of Pitches	Pitch Diameter	Outside Diameter	Caliper Diameter	No. of Pitches	Pitch Diameter	Outside Diameter	Caliper Diameter
6	0.500	0.583	0.370	71	5.652	5.796	5.521	136	10.823	10.970	10.693
7	0.576	0.669	0.432	72	5.732	5.876	5.602	137	10.903	11.050	10.772
8	0.653	0.754	0.523	73	5.811	5.956	5.680	138	10.983	11.130	10.853
9	0.731	0.837	0.591	74	5.891	6.035	5.761	139	11.062	11.209	10.932
10	0.809	0.919	0.679	75	5.970	6.115	5.839	140	11.142	11.289	11.012
11	0.887	1.002	0.748	76	6.050	6.195	5.920	141	11.221	11.369	11.091
12	0.966	1.083	0.836	77	6.129	6.274	5.998	142	11.301	11.448	11.171
13	1.045	1.167	0.907	78	6.209	6.354	6.079	143	11.380	11.528	11.250
14	1.124	1.246	0.994	79	6.288	6.433	6.157	144	11.460	11.607	11.330
15	1.203	1.326	1.066	80	6.368	6.513	6.238	145	11.540	11.687	11.409
16	1.282	1.407	1.152	81	6.448	6.593	6.317	146	11.619	11.767	11.489
17	1.361	1.487	1.225	82	6.527	6.672	6.397	147	11.699	11.846	11.568
18	1.440	1.568	1.310	83	6.607	6.752	6.476	148	11.779	11.926	11.649
19	1.519	1.648	1.383	84	6.686	6.832	6.556	149	11.858	12.005	11.727
20	1.598	1.729	1.468	85	6.766	6.911	6.635	150	11.938	12.084	11.807
21	1.678	1.809	1.543	86	6.845	6.991	6.715	151	12.017	12.164	11.886
22	1.757	1.889	1.627	87	6.925	7.070	6.794	152	12.097	12.244	11.966
23	1.836	1.969	1.702	88	7.004	7.150	6.874	153	12.176	12.323	12.045
24	1.915	2.049	1.785	89	7.084	7.230	6.953	154	12.256	12.403	12.125
25	1.995	2.129	1.861	90	7.164	7.309	7.034	155	12.335	12.482	12.204
26	2.074	2.209	1.944	91	7.243	7.389	7.112	156	12.415	12.562	12.284
27	2.154	2.289	2.020	92	7.323	7.468	7.193	157	12.494	12.641	12.363
28	2.233	2.369	2.103	93	7.402	7.548	7.271	158	12.574	12.721	12.444
29	2.312	2.449	2.179	94	7.482	7.628	7.352	159	12.654	12.801	12.523
30	2.392	2.529	2.262	95	7.561	7.707	7.430	160	12.733	12.881	12.603
31	2.471	2.609	2.338	96	7.641	7.787	7.511	161	12.813	12.960	12.682
32	2.551	2.688	2.421	97	7.720	7.866	7.589	162	12.893	13.039	12.762
33	2.630	2.768	2.497	98	7.800	7.946	7.670	163	12.972	13.119	12.841
34	2.710	2.848	2.580	99	7.880	8.026	7.749	164	13.051	13.199	12.921
35	2.789	2.928	2.656	100	7.959	8.105	7.829	165	13.131	13.278	13.000
36	2.869	3.008	2.739	101	8.039	8.185	7.908	166	13.211	13.357	13.080
37	2.948	3.087	2.815	102	8.118	8.264	7.988	167	13.290	13.437	13.159
38	3.028	3.167	2.898	103	8.198	8.344	8.067	168	13.370	13.517	13.239
39	3.107	3.247	2.975	104	8.277	8.424	8.147	169	13.450	13.597	13.318
40	3.187	3.327	3.057	105	8.357	8.503	8.226	170	13.529	13.676	13.398
41	3.266	3.406	3.134	106	8.437	8.583	8.307	171	13.608	13.756	13.477
42	3.346	3.486	3.216	107	8.516	8.662	8.385	172	13.688	13.835	13.558
43	3.425	3.566	3.293	108	8.596	8.742	8.466	173	13.768	13.915	13.637
44	3.505	3.646	3.375	109	8.675	8.822	8.544	174	13.847	13.995	13.717
45	3.584	3.725	3.452	110	8.755	8.901	8.625	175	13.927	14.074	13.796
46	3.664	3.805	3.534	111	8.834	8.981	8.703	176	14.006	14.154	13.876
47	3.743	3.885	3.611	112	8.914	9.060	8.784	177	14.086	14.233	13.955
48	3.823	3.964	3.693	113	8.994	9.140	8.863	178	14.166	14.313	14.035
49	3.902	4.044	3.770	114	9.073	9.220	8.943	179	14.245	14.392	14.114
50	3.982	4.124	3.852	115	9.153	9.299	9.022	180	14.325	14.472	14.195
51	4.061	4.203	3.929	116	9.232	9.379	9.102	181	14.404	14.551	14.273
52	4.141	4.283	4.011	117	9.312	9.458	9.181	182	14.484	14.631	14.353
53	4.220	4.363	4.088	118	9.391	9.538	9.261	183	14.564	14.711	14.433
54	4.300	4.442	4.170	119	9.471	9.618	9.340	184	14.643	14.790	14.513
55	4.379	4.522	4.247	120	9.550	9.697	9.420	185	14.722	14.870	14.591
56	4.459	4.602	4.329	121	9.630	9.777	9.499	186	14.803	14.949	14.672
57	4.538	4.681	4.407	122	9.709	9.856	9.579	187	14.882	15.029	14.751
58	4.618	4.761	4.488	123	9.789	9.936	9.658	188	14.961	15.109	14.831
59	4.697	4.841	4.566	124	9.869	10.016	9.739	189	15.041	15.188	14.910
60	4.777	4.920	4.647	125	9.949	10.095	9.818	190	15.120	15.268	14.990
61	4.857	5.000	4.725	126	10.028	10.175	9.898	191	15.200	15.347	15.069
62	4.936	5.080	4.806	127	10.108	10.255	9.977	192	15.279	15.427	15.149
63	5.016	5.159	4.884	128	10.187	10.334	10.057	193	15.359	15.507	15.228
64	5.095	5.239	4.965	129	10.267	10.414	10.136	194	15.439	15.586	15.308
65	5.175	5.319	5.044	130	10.346	10.493	10.216	195	15.518	15.666	15.387
66	5.254	5.398	5.124	131	10.426	10.573	10.295	196	15.598	15.745	15.467
67	5.334	5.478	5.203	132	10.505	10.652	10.375	197	15.678	15.824	15.547
68	5.413	5.558	5.283	133	10.585	10.732	10.454	198	15.757	15.904	15.626
69	5.493	5.637	5.362	134	10.664	10.811	10.534	199	15.837	15.984	15.706
70	5.572	5.717	5.442	135	10.744	10.891	10.613	200	15.916	16.064	15.786

Odd tooth "bottom diameters" equal pitch diameters minus .130".

No. 35
3/8" Pitch

**Sprocket
Diameter**

Martin

Roller Chain Sprocket Diameters

No. of Pitches	Pitch Diameter	Outside Diameter	Caliper Diameter	No. of Pitches	Pitch Diameter	Outside Diameter	Caliper Diameter	No. of Pitches	Pitch Diameter	Outside Diameter	Caliper Diameter
5	0.638	0.741	0.407	71	8.478	8.694	8.276	136	16.235	16.456	16.035
6	0.750	0.875	0.550	72	8.597	8.814	8.397	137	16.355	16.575	16.154
7	0.864	1.004	0.643	73	8.717	8.933	8.514	138	16.474	16.695	16.274
8	0.980	1.130	0.780	74	8.836	9.053	8.636	139	16.593	16.814	16.392
9	1.097	1.256	0.880	75	8.955	9.172	8.753	140	16.713	16.934	16.513
10	1.214	1.379	1.014	76	9.074	9.292	8.874	141	16.832	17.053	16.631
11	1.331	1.502	1.117	77	9.194	9.411	8.992	142	16.952	17.172	16.752
12	1.449	1.625	1.249	78	9.313	9.531	9.113	143	17.071	17.292	16.870
13	1.567	1.746	1.356	79	9.432	9.650	9.231	144	17.190	17.411	16.990
14	1.685	1.868	1.485	80	9.552	9.770	9.352	145	17.309	17.531	17.108
15	1.804	1.989	1.594	81	9.671	9.889	9.469	146	17.429	17.650	17.229
16	1.922	2.110	1.722	82	9.791	10.008	9.591	147	17.548	17.769	17.347
17	2.041	2.231	1.832	83	9.910	10.128	9.708	148	17.667	17.889	17.467
18	2.160	2.352	1.960	84	10.029	10.247	9.829	149	17.787	18.008	17.586
19	2.279	2.472	2.071	85	10.148	10.367	9.947	150	17.906	18.128	17.706
20	2.397	2.593	2.197	86	10.268	10.486	10.068	151	18.026	18.247	17.825
21	2.516	2.713	2.309	87	10.387	10.605	10.285	152	18.145	18.366	17.945
22	2.635	2.833	2.435	88	10.506	10.725	10.306	153	18.264	18.486	18.063
23	2.754	2.954	2.548	89	10.626	10.844	10.424	154	18.384	18.605	18.184
24	2.873	3.074	2.673	90	10.745	10.964	10.545	155	18.503	18.724	18.302
25	2.992	3.194	2.786	91	10.865	11.083	10.663	156	18.623	18.844	18.423
26	3.111	3.314	2.911	92	10.984	11.202	10.784	157	18.742	18.963	18.541
27	3.230	3.434	3.025	93	11.103	11.322	10.902	158	18.861	19.082	18.661
28	3.349	3.553	3.149	94	11.223	11.441	11.023	159	18.981	19.202	18.780
29	3.468	3.673	3.263	95	11.342	11.561	11.140	160	19.100	19.321	18.900
30	3.588	3.793	3.388	96	11.461	11.680	11.261	161	19.219	19.440	19.018
31	3.707	3.913	3.502	97	11.581	11.799	11.379	162	19.338	19.560	19.138
32	3.826	4.032	3.626	98	11.700	11.919	11.500	163	19.458	19.679	19.257
33	3.945	4.152	3.741	99	11.819	12.038	11.618	164	19.577	19.799	19.377
34	4.064	4.272	3.864	100	11.939	12.158	11.739	165	19.697	19.918	19.496
35	4.184	4.392	3.979	101	12.058	12.277	11.856	166	19.816	20.037	19.616
36	4.303	4.511	4.103	102	12.177	12.396	11.977	167	19.935	20.090	19.734
37	4.422	4.631	4.218	103	12.297	12.516	12.095	168	20.055	20.276	19.855
38	4.541	4.751	4.341	104	12.416	12.635	12.216	169	20.174	20.396	19.973
39	4.661	4.870	4.457	105	12.536	12.755	12.334	170	20.294	20.515	20.094
40	4.780	4.990	4.580	106	12.655	12.874	12.455	171	20.413	20.634	20.212
41	4.899	5.109	4.695	107	12.774	12.993	12.573	172	20.532	20.754	20.332
42	5.018	5.229	4.818	108	12.893	13.113	12.693	173	20.652	20.873	20.451
43	5.138	5.349	4.934	109	13.013	13.232	12.811	174	20.771	20.993	20.571
44	5.257	5.468	5.057	110	13.132	13.352	12.932	175	20.890	21.112	20.689
45	5.376	5.588	5.173	111	13.251	13.471	13.050	176	21.010	21.231	20.810
46	5.495	5.707	5.295	112	13.371	13.590	13.171	177	21.129	21.351	20.928
47	5.615	5.827	5.411	113	13.490	13.710	13.289	178	21.248	21.470	21.048
48	5.734	5.946	5.534	114	13.610	13.829	13.410	179	21.368	21.589	21.167
49	5.853	6.066	5.650	115	13.729	13.949	13.528	180	21.487	21.709	21.287
50	5.972	6.186	5.772	116	13.848	14.068	13.648	181	21.606	21.828	21.406
51	6.092	6.305	5.889	117	13.968	14.187	13.766	182	21.726	21.948	21.526
52	6.211	6.425	6.011	118	14.087	14.307	13.887	183	21.845	22.067	21.644
53	6.330	6.544	6.127	119	14.206	14.426	14.005	184	21.965	22.186	21.765
54	6.449	6.663	6.249	120	14.326	14.546	14.126	185	22.084	22.306	21.883
55	6.569	6.783	6.366	121	14.445	14.665	14.244	186	22.203	22.425	22.003
56	6.688	6.903	6.488	122	14.564	14.784	14.364	187	22.323	22.544	22.122
57	6.807	7.022	6.605	123	14.684	14.904	14.482	188	22.442	22.664	22.242
58	6.927	7.142	6.727	124	14.803	15.023	14.603	189	22.561	22.783	22.360
59	7.046	7.261	6.843	125	14.922	15.143	14.721	190	22.681	22.902	22.481
60	7.165	7.380	6.965	126	15.042	15.262	14.842	191	22.800	23.022	22.599
61	7.285	7.500	7.082	127	15.161	15.381	14.960	192	22.919	23.141	22.719
62	7.404	7.619	7.204	128	15.281	15.501	15.081	193	23.039	23.261	22.838
63	7.523	7.739	7.321	129	15.400	15.620	15.199	194	23.158	23.380	22.958
64	7.643	7.859	7.443	130	15.519	15.740	15.319	195	23.277	23.499	23.177
65	7.762	7.978	7.560	131	15.639	15.859	15.437	196	23.397	23.619	23.197
66	7.881	8.097	7.681	132	15.758	15.978	15.558	197	23.516	23.738	23.315
67	8.001	8.217	7.798	133	15.877	16.098	15.676	198	23.636	23.858	23.436
68	8.120	8.336	7.920	134	15.996	16.217	15.796	199	23.755	23.977	23.554
69	8.239	8.456	8.037	135	16.116	16.337	15.915	200	23.874	24.096	23.674
70	8.358	8.575	8.158								



Sprocket Diameter

No. 40 1/2" Pitch

Roller Chain Sprocket Diameters

No. of Pitches	Pitch Diameter	Outside Diameter	Caliper Diameter	No. of Pitches	Pitch Diameter	Outside Diameter	Caliper Diameter	No. of Pitches	Pitch Diameter	Outside Diameter	Caliper Diameter
5	0.851	0.988	0.497	71	11.304	11.592	10.988	136	21.647	21.941	21.334
6	1.000	1.166	0.688	72	11.463	11.752	11.151	137	21.806	22.100	21.492
7	1.152	1.338	0.812	73	11.622	11.911	11.306	138	21.965	22.259	21.653
8	1.307	1.507	0.995	74	11.781	12.070	11.468	139	22.124	22.419	21.810
9	1.462	1.674	1.127	75	11.940	12.229	11.625	140	22.284	22.578	21.971
10	1.618	1.839	1.305	76	12.099	12.389	11.786	141	22.442	22.737	22.129
11	1.775	2.003	1.444	77	12.258	12.548	11.943	142	22.602	22.896	22.289
12	1.932	2.166	1.614	78	12.417	12.707	12.105	143	22.761	23.055	22.447
13	2.089	2.328	1.761	79	12.576	12.866	12.261	144	22.920	23.214	22.607
14	2.247	2.490	1.934	80	12.736	13.026	12.423	145	23.079	23.374	22.765
15	2.405	2.652	2.079	81	12.895	13.185	12.580	146	23.238	23.533	22.926
16	2.563	2.814	2.250	82	13.054	13.344	12.742	147	23.398	23.692	23.088
17	2.721	2.974	2.397	83	13.213	13.503	12.898	148	23.557	23.851	23.244
18	2.879	3.136	2.567	84	13.372	13.663	13.059	149	23.716	24.010	23.402
19	3.038	3.292	2.715	85	13.531	13.822	13.216	150	23.875	24.170	23.562
20	3.196	3.457	2.883	86	13.690	13.981	13.373	151	24.034	24.329	23.720
21	3.355	3.618	3.033	87	13.849	14.140	13.534	152	24.193	24.488	23.880
22	3.513	3.778	3.201	88	14.009	14.299	13.696	153	24.352	24.647	24.038
23	3.672	3.938	3.351	89	14.168	14.459	13.853	154	24.512	24.806	24.199
24	3.831	4.098	3.518	90	14.327	14.618	14.014	155	24.672	24.965	24.357
25	3.989	4.258	3.669	91	14.486	14.777	14.171	156	24.830	25.124	24.517
26	4.148	4.418	3.835	92	14.645	14.936	14.332	157	24.989	25.284	24.675
27	4.307	4.578	3.987	93	14.804	15.096	14.489	158	24.148	25.443	24.835
28	4.465	4.738	4.153	94	14.963	15.255	14.651	159	25.307	25.602	24.993
29	4.625	4.898	4.305	95	15.122	15.414	14.808	160	25.466	25.761	25.154
30	4.783	5.057	4.471	96	15.282	15.573	14.969	161	25.625	25.920	25.312
31	4.942	5.217	4.623	97	15.441	15.732	15.126	162	25.785	26.080	25.472
32	5.101	5.376	4.788	98	15.600	15.892	15.287	163	25.944	26.239	25.630
33	5.260	5.536	4.941	99	15.759	16.051	15.445	164	26.103	26.398	25.790
34	5.419	5.696	5.107	100	15.918	16.210	15.605	165	26.262	26.557	25.948
35	5.578	5.856	5.260	101	16.077	16.369	15.763	166	26.421	26.716	26.109
36	5.737	6.015	5.425	102	16.236	16.528	15.924	167	26.581	26.876	26.266
37	5.896	6.174	5.578	103	16.395	16.688	16.081	168	25.739	27.035	26.427
38	6.055	6.334	5.742	104	16.555	16.847	16.242	169	26.899	27.194	26.585
39	6.214	6.494	5.896	105	16.714	17.006	16.399	170	27.058	27.353	26.745
40	6.373	6.653	6.061	106	16.873	17.165	16.561	171	27.217	27.512	26.903
41	6.532	6.812	6.214	107	17.032	17.324	16.717	172	27.376	27.671	27.063
42	6.691	6.972	6.379	108	17.191	17.484	16.878	173	27.535	27.831	27.221
43	6.850	7.132	6.532	109	17.351	17.643	17.036	174	27.694	27.990	27.382
44	7.009	7.291	6.696	110	17.509	17.802	17.197	175	27.854	28.149	27.540
45	7.168	7.450	6.851	111	17.668	17.962	17.304	176	28.013	28.308	27.700
46	7.327	7.609	7.014	112	17.827	18.121	17.515	177	28.172	28.467	27.858
47	7.486	7.769	7.169	113	17.987	18.280	17.672	178	28.331	28.626	28.018
48	7.645	7.928	7.332	114	18.146	18.439	17.834	179	28.490	28.786	28.176
49	7.804	8.088	7.487	115	18.305	18.598	17.991	180	28.649	28.945	28.337
50	7.963	8.248	7.650	116	18.464	18.757	18.151	181	28.808	29.104	28.495
51	8.122	8.406	7.805	117	18.623	18.916	18.309	182	28.968	28.263	28.655
52	8.281	8.566	7.968	118	18.782	19.076	18.470	183	29.127	29.422	28.813
53	8.440	8.725	8.124	119	18.941	19.235	18.627	184	29.286	29.581	28.973
54	8.599	8.884	8.286	120	19.101	19.394	18.788	185	29.445	29.741	29.131
55	8.758	9.044	8.442	121	19.260	19.553	18.946	186	29.604	29.900	29.291
56	8.917	9.204	8.605	122	19.419	19.712	19.106	187	29.763	30.059	29.450
57	9.077	9.362	8.760	123	19.578	19.872	19.264	188	29.922	30.218	29.610
58	9.235	9.522	8.924	124	19.737	20.031	19.425	189	30.082	30.377	29.768
59	9.395	9.628	9.078	125	19.896	20.190	19.582	190	30.241	30.536	29.928
60	9.554	9.840	9.241	126	20.056	20.349	19.743	191	30.400	30.696	30.086
61	9.713	10.000	9.397	127	20.215	20.508	19.900	192	30.559	30.855	30.246
62	9.872	10.159	9.559	128	20.374	20.667	20.061	193	30.718	31.014	30.404
63	10.031	10.319	9.715	129	20.533	20.827	20.219	194	30.877	31.173	30.565
64	10.190	10.478	9.872	130	20.692	20.986	20.379	195	31.037	31.332	30.723
65	10.349	10.673	10.033	131	20.851	21.145	20.537	196	31.196	31.491	30.878
66	10.508	10.796	10.195	132	21.010	21.304	20.698	197	31.355	31.651	31.042
67	10.667	10.955	10.352	133	21.169	21.463	20.855	198	31.514	31.810	31.202
68	10.826	11.115	10.514	134	21.329	21.623	21.016	199	31.673	31.969	31.359
69	10.985	11.274	10.670	135	21.488	21.782	21.174	200	31.832	32.128	31.520
70	11.145	11.433	10.832								

No. 50
5/8" Pitch

**Sprocket
Diameter**

Martin

Roller Chain Sprocket Diameters

No. of Pitches	Pitch Diameter	Outside Diameter	Caliper Diameter	No. of Pitches	Pitch Diameter	Outside Diameter	Caliper Diameter	No. of Pitches	Pitch Diameter	Outside Diameter	Caliper Diameter
5	1.063	1.235	0.611	71	14.129	14.491	13.726	136	27.059	27.426	26.659
6	1.250	1.458	0.850	72	14.329	14.690	13.929	137	27.258	27.626	26.856
7	1.441	1.673	1.104	73	14.528	14.889	14.124	138	27.457	27.824	27.057
8	1.633	1.884	1.233	74	14.726	15.088	14.326	139	27.656	28.024	27.254
9	1.828	2.093	1.400	75	14.925	15.287	14.522	140	27.854	28.223	27.454
10	2.023	2.299	1.623	76	15.124	15.486	14.724	141	28.053	28.421	27.652
11	2.219	2.504	1.796	77	15.323	15.685	14.920	142	28.253	28.621	27.853
12	2.415	2.708	2.015	78	15.522	15.884	15.122	143	28.451	28.819	28.050
13	2.612	2.911	2.193	79	15.721	16.083	15.318	144	28.650	29.018	28.250
14	2.809	3.113	2.409	80	15.919	16.283	15.519	145	28.849	28.218	28.447
15	3.006	3.315	2.590	81	16.119	16.481	15.715	146	29.048	29.416	28.608
16	3.204	3.517	2.804	82	16.318	16.681	15.918	147	29.247	29.615	28.845
17	3.401	3.718	2.987	83	16.516	16.879	16.113	148	29.446	29.814	29.046
18	3.599	3.919	3.159	84	16.715	17.079	16.315	149	29.645	30.013	29.243
19	3.798	4.121	3.384	85	16.914	17.278	16.511	150	29.844	30.213	29.444
20	3.995	4.321	3.595	86	17.113	17.476	16.713	151	30.043	30.411	29.641
21	4.194	4.522	3.782	87	17.312	17.676	16.909	152	30.241	30.610	29.841
22	4.392	4.722	3.992	88	17.511	17.874	17.111	153	30.441	30.809	30.039
23	4.590	4.923	4.179	89	17.709	18.074	17.307	154	30.639	31.008	30.239
24	4.788	5.123	4.388	90	17.909	18.273	17.509	155	30.838	31.207	30.437
25	4.987	5.323	4.577	91	18.108	18.472	17.705	156	31.038	31.406	30.638
26	5.185	5.523	4.785	92	18.306	18.671	17.906	157	31.236	31.605	30.835
27	5.384	5.723	4.975	93	18.505	18.870	18.103	158	31.435	31.804	31.035
28	5.582	5.922	5.182	94	18.704	19.069	18.304	159	31.634	32.003	31.233
29	5.781	6.122	5.371	95	18.903	19.268	18.501	160	31.833	32.202	31.433
30	5.979	6.321	5.579	96	19.102	19.467	18.702	161	32.032	32.401	31.630
31	6.178	6.521	5.770	97	19.301	19.666	18.898	162	32.231	32.600	31.831
32	6.376	6.721	5.976	98	19.500	19.865	19.100	163	32.430	32.799	32.082
33	6.575	6.921	6.168	99	19.699	20.064	19.296	164	32.629	32.998	32.229
34	6.774	7.120	6.374	100	19.898	20.263	19.498	165	32.828	33.197	32.426
35	6.973	7.319	6.565	101	20.096	20.462	19.694	166	33.027	33.396	32.627
36	7.171	7.519	6.771	102	20.296	20.661	19.896	167	33.226	33.595	32.824
37	7.370	7.718	6.963	103	20.494	20.860	20.092	168	33.424	33.794	33.024
38	7.569	7.918	7.169	104	20.693	21.059	20.293	169	33.624	33.993	33.222
39	7.768	8.117	7.361	105	20.893	21.258	20.490	170	33.823	34.192	33.423
40	7.966	8.316	7.566	106	21.091	21.457	20.691	171	34.021	34.391	33.620
41	8.165	8.516	7.759	107	21.290	21.656	20.888	172	34.220	34.589	33.820
42	8.364	8.715	7.964	108	21.489	21.855	21.089	173	34.419	34.789	34.018
43	8.563	8.914	8.157	109	21.688	22.054	21.286	174	34.618	34.988	34.218
44	8.761	9.114	8.361	110	21.887	22.253	21.487	175	34.817	35.186	34.416
45	8.960	9.313	8.554	111	22.086	22.452	21.684	176	35.016	35.386	34.616
46	9.159	9.512	8.759	112	22.284	22.651	21.884	177	35.215	35.584	34.814
47	9.358	9.711	8.952	113	22.484	22.850	22.081	178	35.414	35.783	35.014
48	9.556	9.911	9.156	114	22.683	23.049	22.283	179	35.613	35.983	35.211
49	9.755	10.110	9.350	115	22.881	23.248	22.479	180	35.812	36.181	35.412
50	9.954	10.309	9.554	116	23.080	23.447	22.680	181	36.011	36.380	35.609
51	10.153	10.508	9.748	117	23.279	23.646	22.827	182	36.209	36.579	35.809
52	10.351	10.708	9.951	118	23.478	23.845	23.078	183	36.409	36.778	36.007
53	10.550	10.907	10.146	119	23.677	24.044	23.275	184	36.608	36.977	36.208
54	10.749	11.106	10.349	120	23.876	24.243	23.476	185	36.806	37.176	36.405
55	10.948	11.305	10.543	121	24.075	24.442	23.673	186	37.005	37.375	36.605
56	11.147	11.504	10.747	122	24.274	24.641	23.874	187	37.204	37.574	36.803
57	11.346	11.703	10.941	123	24.473	24.840	24.071	188	37.403	37.773	37.003
58	11.544	11.903	11.144	124	24.672	25.039	24.272	189	37.602	37.972	37.201
59	11.743	12.102	11.339	125	24.871	25.238	24.469	190	37.801	38.171	37.401
60	11.942	12.301	11.542	126	25.069	25.437	24.669	191	38.000	38.370	37.599
61	12.141	12.500	11.737	127	25.269	25.636	24.867	192	38.199	38.569	37.799
62	12.340	12.699	11.940	128	25.468	25.834	25.068	193	38.398	38.768	37.998
63	12.539	12.898	12.135	129	25.666	26.034	25.264	194	38.597	38.967	38.197
64	12.738	13.098	12.338	130	25.865	26.233	25.465	195	38.796	39.166	38.394
65	12.936	13.296	12.533	131	26.064	26.432	25.662	196	38.994	39.364	38.594
66	13.135	13.496	12.735	132	26.263	26.631	25.863	197	39.194	39.564	38.792
67	13.334	13.694	12.930	133	26.462	26.829	26.060	198	39.393	39.763	38.993
68	13.533	13.894	13.133	134	26.661	27.029	26.261	199	39.591	39.961	39.190
69	13.732	14.093	13.328	135	26.860	27.228	26.458	200	39.791	40.161	39.391
70	13.931	14.292	13.531								



Sprocket Diameter

No. 60

3/4" Pitch

Roller Chain Sprocket Diameters

No. of Pitches	Pitch Diameter	Outside Diameter	Caliper Diameter	No. of Pitches	Pitch Diameter	Outside Diameter	Caliper Diameter	No. of Pitches	Pitch Diameter	Outside Diameter	Caliper Diameter
5	1.276	1.482	0.745	71	16.955	17.389	16.482	136	32.471	32.912	32.002
6	1.500	1.749	1.031	72	17.195	17.628	16.726	137	32.709	33.151	32.238
7	1.729	2.007	1.216	73	17.433	17.867	16.960	138	32.948	33.389	32.479
8	1.960	2.261	1.491	74	17.672	18.106	17.203	139	33.187	33.629	32.716
9	2.193	2.511	1.691	75	17.910	18.344	17.437	140	33.425	33.867	32.956
10	2.427	2.759	1.958	76	18.149	18.584	17.680	141	33.664	34.106	33.193
11	2.663	3.005	2.166	77	18.388	18.822	17.915	142	33.903	34.345	33.434
12	2.898	3.249	2.429	78	18.626	19.061	18.157	143	34.142	34.583	33.670
13	3.134	3.493	2.642	79	18.865	19.300	18.392	144	34.380	34.822	33.911
14	3.371	3.736	2.902	80	19.103	19.539	18.634	145	34.619	35.061	34.148
15	3.608	3.978	3.119	81	19.343	19.778	18.870	146	34.858	35.300	34.389
16	3.845	4.220	3.380	82	19.581	20.017	19.112	147	35.096	35.538	34.625
17	4.082	4.462	3.595	83	19.820	20.255	19.347	148	35.335	35.777	34.866
18	4.319	4.703	3.850	84	20.058	20.495	19.589	149	35.574	36.016	35.103
19	4.557	4.945	4.072	85	20.297	20.733	19.824	150	35.813	36.255	35.344
20	4.794	5.186	4.325	86	20.536	20.972	20.067	151	36.051	36.494	35.580
21	5.033	5.426	4.549	87	20.774	21.211	20.302	152	36.300	36.732	35.821
22	5.270	5.666	4.801	88	21.013	21.449	20.544	153	36.529	36.971	36.058
23	5.508	5.907	5.026	89	21.251	21.689	20.779	154	36.767	37.210	36.298
24	5.746	6.147	5.277	90	21.491	21.927	21.022	155	37.006	37.448	36.535
25	5.984	6.387	5.503	91	21.729	22.166	21.257	156	37.245	37.688	36.776
26	6.222	6.627	5.753	92	21.968	22.405	21.499	157	37.484	37.926	37.013
27	6.461	6.867	5.980	93	22.206	22.644	21.734	158	37.722	38.165	37.253
28	6.698	7.106	6.229	94	22.445	22.883	21.976	159	37.961	38.404	37.490
29	6.937	7.346	6.458	95	22.684	23.121	22.212	160	38.200	38.642	37.731
30	7.175	7.586	6.706	96	22.922	23.360	22.453	161	38.438	38.881	37.968
31	7.413	7.826	6.935	97	23.162	23.599	22.689	162	38.677	39.120	38.208
32	7.652	8.065	7.183	98	23.400	23.838	22.931	163	38.916	39.359	38.445
33	7.890	8.305	7.412	99	23.639	24.077	23.167	164	39.155	39.597	38.686
34	8.129	8.544	7.660	100	23.877	24.316	23.408	165	39.393	39.836	38.922
35	8.367	8.783	7.889	101	24.116	24.554	23.644	166	39.632	40.075	39.163
36	8.606	9.023	8.137	102	24.355	24.793	23.886	167	39.871	40.314	39.400
37	8.844	9.262	8.367	103	24.593	25.032	24.121	168	40.109	40.553	39.640
38	9.083	9.501	8.614	104	24.832	25.271	24.363	169	40.349	40.791	39.877
39	9.321	9.740	8.844	105	25.071	25.510	24.599	170	40.587	41.030	40.118
40	9.560	9.980	9.091	106	25.310	25.748	24.841	171	40.826	41.269	40.355
41	9.798	10.219	9.321	107	25.548	25.987	25.076	172	41.064	41.507	40.595
42	10.037	10.458	9.568	108	25.787	26.226	25.318	173	41.303	41.747	40.832
43	10.275	10.697	9.799	109	26.026	26.465	25.554	174	41.542	41.985	41.073
44	10.514	10.937	10.045	110	26.264	26.704	25.795	175	41.780	42.224	41.310
45	10.752	11.176	10.276	111	26.503	26.942	26.031	176	42.020	42.463	41.551
46	10.991	11.414	10.522	112	26.741	27.181	26.272	177	42.258	42.701	41.787
47	11.229	11.654	10.754	113	26.981	27.420	26.507	178	42.497	42.940	42.028
48	11.468	11.893	10.999	114	27.219	27.659	26.750	179	42.735	43.179	42.265
49	11.706	12.132	11.231	115	27.458	27.898	26.986	180	42.974	43.418	42.505
50	11.945	12.371	11.476	116	27.696	28.136	27.227	181	43.213	43.656	42.742
51	12.183	12.610	11.708	117	27.935	28.375	27.464	182	43.451	43.895	42.982
52	12.422	12.849	11.953	118	28.174	28.614	27.705	183	43.691	44.134	43.220
53	12.660	13.088	12.186	119	28.412	28.853	27.941	184	43.929	44.372	43.460
54	12.899	13.327	12.430	120	28.652	29.091	28.183	185	44.168	44.612	43.697
55	13.137	13.566	12.663	121	28.890	29.330	28.418	186	44.406	44.850	43.937
56	13.376	13.805	12.907	122	29.129	29.569	28.660	187	44.645	45.089	44.174
57	13.615	14.044	13.140	123	29.367	29.808	28.896	188	44.884	45.328	44.415
58	13.853	14.283	13.384	124	29.606	30.047	29.137	189	45.122	45.566	44.652
59	14.092	14.522	13.618	125	29.845	30.285	29.373	190	45.362	45.805	44.893
60	14.330	14.761	13.861	126	30.083	30.524	29.614	191	45.600	46.044	45.129
61	14.570	15.000	14.095	127	30.323	30.763	29.851	192	45.839	46.283	45.370
62	14.808	15.239	14.339	128	30.561	31.001	30.092	193	46.077	46.521	45.607
63	15.047	15.478	14.573	129	30.800	31.241	30.328	194	46.316	46.760	45.847
64	15.285	15.717	14.816	130	31.038	31.479	30.569	195	46.555	46.999	46.084
65	15.524	15.956	15.050	131	31.277	31.718	30.806	196	46.793	47.237	46.324
66	15.762	16.195	15.293	132	31.516	31.957	31.047	197	47.033	47.477	46.562
67	16.001	16.433	15.528	133	31.754	32.195	31.283	198	47.271	47.715	46.802
68	16.240	16.673	15.771	134	31.993	32.435	31.524	199	47.510	47.954	47.039
69	16.478	16.911	16.005	135	32.232	32.673	31.761	200	47.749	48.193	47.280
70	16.717	17.150	16.248								

No. 80

1" Pitch

Sprocket Diameter



Roller Chain Sprocket Diameters

No. of Pitches	Pitch Diameter	Outside Diameter	Caliper Diameter	No. of Pitches	Pitch Diameter	Outside Diameter	Caliper Diameter	No. of Pitches	Pitch Diameter	Outside Diameter	Caliper Diameter
5	1.701	1.976	0.993	71	22.607	23.185	21.977	136	43.294	43.882	42.669
6	2.000	2.332	1.375	72	22.926	23.504	22.301	137	43.612	44.201	42.984
7	2.305	2.676	1.622	73	23.244	23.822	22.613	138	43.931	44.519	43.306
8	2.613	3.014	1.988	74	23.562	24.141	22.937	139	44.249	44.838	43.621
9	2.924	3.348	2.254	75	23.880	24.459	23.250	140	44.567	45.156	43.942
10	3.236	3.678	2.611	76	24.198	24.778	23.573	141	44.885	45.474	44.258
11	3.550	4.006	2.888	77	24.517	25.096	23.887	142	45.204	45.793	44.579
12	3.864	4.332	3.239	78	24.835	25.415	24.210	143	45.522	46.111	44.894
13	4.179	4.657	3.523	79	25.153	25.733	24.523	144	45.840	46.429	45.215
14	4.494	4.981	3.869	80	25.471	26.052	24.846	145	46.158	46.748	45.531
15	4.810	5.304	4.158	81	25.790	26.370	25.160	146	46.477	47.066	45.852
16	5.126	5.627	4.501	82	26.108	26.689	25.483	147	46.795	47.384	46.167
17	5.442	5.949	4.794	83	26.426	27.007	25.796	148	47.113	47.703	46.488
18	5.759	6.271	5.134	84	26.744	27.326	26.119	149	47.432	48.021	46.804
19	6.076	6.593	5.430	85	27.062	27.644	26.433	150	47.750	48.340	47.125
20	6.392	6.914	5.767	86	27.381	27.962	26.756	151	48.068	48.658	47.441
21	6.710	7.235	6.066	87	27.699	28.281	27.069	152	48.386	48.976	47.761
22	7.027	7.555	6.402	88	28.017	28.599	27.392	153	48.705	49.295	48.077
23	7.344	7.876	6.702	89	28.335	28.918	27.706	154	49.023	49.613	48.398
24	7.661	8.196	7.036	90	28.654	29.236	28.029	155	49.341	49.931	48.714
25	7.979	8.516	7.338	91	28.972	29.555	28.343	156	49.660	50.250	49.035
26	8.296	8.836	7.671	92	29.290	29.873	28.665	157	49.978	50.568	49.351
27	8.614	9.156	7.974	93	29.608	30.192	28.979	158	50.296	50.886	49.671
28	8.931	9.475	8.306	94	29.927	30.510	29.302	159	50.615	51.205	49.987
29	9.249	9.795	8.611	95	30.245	30.828	29.616	160	50.933	51.523	50.308
30	9.567	10.114	8.942	96	30.563	31.147	29.938	161	51.251	51.841	50.624
31	9.884	10.434	9.247	97	30.882	31.465	30.252	162	51.569	52.160	50.944
32	10.202	10.753	9.577	98	31.200	31.784	30.575	163	51.888	52.478	51.260
33	10.520	11.073	9.883	99	31.518	32.102	30.889	164	52.206	52.796	51.581
34	10.838	11.392	10.213	100	31.836	32.421	31.211	165	52.524	53.115	51.897
35	11.156	11.711	10.520	101	32.154	32.739	31.526	166	52.843	53.433	52.218
36	11.471	12.030	10.849	102	32.473	33.057	31.848	167	53.161	53.752	52.533
37	11.792	12.349	11.156	103	32.791	33.376	32.162	168	53.479	54.070	52.854
38	12.110	12.668	11.485	104	33.109	33.694	32.484	169	53.798	54.388	53.170
39	12.428	12.987	11.792	105	33.428	34.013	32.799	170	54.116	54.707	53.491
40	12.746	13.306	12.121	106	33.746	34.331	33.121	171	54.434	55.025	53.807
41	13.064	13.625	12.429	107	34.064	34.649	33.435	172	54.752	55.343	54.127
42	13.382	13.944	12.757	108	34.382	34.968	33.757	173	55.071	55.662	54.443
43	13.700	14.263	13.065	109	34.701	35.286	34.072	174	55.389	55.980	54.764
44	14.018	14.582	13.393	110	35.019	35.605	34.394	175	55.707	56.298	55.080
45	14.336	14.901	13.702	111	35.337	35.923	34.709	176	56.026	56.617	55.401
46	14.654	15.219	14.029	112	35.655	36.241	35.030	177	56.344	56.935	55.717
47	14.972	15.538	14.338	113	35.974	36.560	35.345	178	56.662	57.253	56.037
48	15.290	15.857	14.665	114	36.292	36.878	35.667	179	56.980	57.572	56.353
49	15.608	16.176	14.975	115	36.610	37.197	35.982	180	57.299	57.890	56.674
50	15.926	16.495	15.301	116	36.928	37.515	36.303	181	57.617	58.208	56.990
51	16.244	16.813	15.611	117	37.274	37.833	36.618	182	57.935	58.527	57.310
52	16.562	17.132	15.937	118	37.565	38.152	36.940	183	58.254	58.845	57.626
53	16.880	17.451	16.248	119	37.883	38.470	37.255	184	58.572	59.163	57.947
54	17.198	17.769	16.573	120	38.202	38.788	37.577	185	58.890	59.482	58.263
55	17.516	18.088	16.884	121	38.520	39.107	37.892	186	59.208	59.800	58.583
56	17.835	18.407	17.210	122	38.838	39.425	38.213	187	59.527	60.118	58.900
57	18.153	18.725	17.521	123	39.156	39.744	38.528	188	59.845	60.437	59.220
58	18.471	19.044	17.846	124	39.457	40.062	38.850	189	60.163	60.755	59.536
59	18.789	19.363	18.157	125	39.793	40.380	39.165	190	60.482	61.073	59.857
60	19.107	19.681	18.482	126	40.111	40.699	39.486	191	60.800	61.392	60.173
61	19.426	20.000	18.794	127	40.430	41.017	39.801	192	61.118	61.710	60.493
62	19.744	20.318	19.119	128	40.748	41.335	40.123	193	61.436	62.028	60.809
63	20.062	20.637	19.431	129	41.066	41.654	40.438	194	61.755	62.347	61.130
64	20.380	20.956	19.755	130	41.384	41.972	40.759	195	62.073	62.665	61.447
65	20.698	21.274	20.067	131	41.703	42.291	41.075	196	62.391	62.983	61.756
66	21.016	21.593	20.391	132	42.021	42.609	41.396	197	62.710	63.302	62.083
67	21.335	21.911	20.704	133	42.339	42.927	41.711	198	63.028	63.620	62.403
68	21.653	22.230	21.028	134	42.657	43.246	42.032	199	63.346	63.938	62.719
69	21.971	22.548	21.340	135	42.976	43.564	42.348	200	63.665	64.257	63.040
70	22.289	22.867	21.664								



Sprocket Diameter

No. 100 1¼" Pitch

Roller Chain Sprocket Diameters

No. of Pitches	Pitch Diameter	Outside Diameter	Caliper Diameter	No. of Pitches	Pitch Diameter	Outside Diameter	Caliper Diameter	No. of Pitches	Pitch Diameter	Outside Diameter	Caliper Diameter
5	2.126	2.470	1.273	71	28.259	28.981	27.502	136	54.118	54.853	53.368
6	2.500	2.915	1.750	72	28.658	29.380	27.908	137	54.515	55.251	53.762
7	2.881	3.345	2.059	73	29.055	29.778	28.298	138	54.914	55.649	54.164
8	3.266	3.768	2.516	74	29.453	30.176	28.703	139	55.311	56.048	54.558
9	3.655	4.185	2.849	75	29.850	30.574	29.094	140	55.709	56.445	54.959
10	4.045	4.598	3.295	76	30.248	30.973	29.498	141	56.106	56.843	55.353
11	4.438	5.008	3.639	77	30.646	31.370	29.890	142	56.505	57.241	55.755
12	4.830	5.415	4.080	78	31.044	31.769	30.294	143	56.903	57.639	56.149
13	5.224	5.821	4.435	79	31.441	32.166	30.685	144	57.300	58.036	56.550
14	5.618	6.226	4.868	80	31.839	32.565	31.089	145	57.698	58.435	56.945
15	6.013	6.630	5.229	81	32.238	32.963	31.481	146	58.096	58.833	57.346
16	6.408	7.034	5.658	82	32.635	33.361	31.885	147	58.494	59.230	57.741
17	6.803	7.436	6.024	83	33.033	33.759	32.277	148	58.891	59.629	58.141
18	7.199	7.839	6.449	84	33.430	34.158	32.680	149	59.290	60.026	58.536
19	7.595	8.241	6.819	85	33.828	34.555	33.072	150	59.688	60.425	58.938
20	7.990	8.643	7.240	86	34.226	34.953	33.476	151	60.085	60.823	59.332
21	8.388	9.044	7.613	87	34.624	35.351	33.868	152	60.483	61.220	59.733
22	8.784	9.444	8.034	88	35.022	35.749	34.272	153	60.881	61.619	60.128
23	9.180	9.845	8.409	89	35.419	36.148	34.664	154	61.279	62.016	60.529
24	9.576	10.245	8.827	90	35.818	36.545	35.068	155	61.676	62.414	60.924
25	9.974	10.645	9.204	91	36.215	36.944	35.460	156	62.075	62.813	61.325
26	10.370	11.045	9.620	92	36.613	37.341	35.863	157	62.473	63.210	61.719
27	10.768	11.445	9.999	93	37.010	37.740	36.255	158	62.870	63.608	62.120
28	11.164	11.844	10.414	94	37.409	38.138	36.659	159	63.269	64.006	62.515
29	11.561	12.244	10.794	95	37.806	38.535	37.051	160	63.666	64.404	62.916
30	11.959	12.643	11.209	96	38.204	38.934	37.454	161	64.064	64.801	63.311
31	12.355	13.043	11.590	97	38.603	39.331	37.847	162	64.461	65.200	63.711
32	12.753	13.441	12.003	98	39.000	39.730	38.250	163	64.860	65.598	64.107
33	13.150	13.841	12.385	99	39.398	40.128	38.643	164	65.258	65.995	64.508
34	13.548	14.240	12.798	100	39.795	40.526	39.045	165	65.655	66.394	64.902
35	13.945	14.639	13.181	101	40.193	40.924	39.438	166	66.054	66.791	65.304
36	14.343	15.038	13.593	102	40.591	41.321	39.841	167	66.451	67.190	65.698
37	14.740	15.436	13.976	103	40.989	41.720	40.234	168	66.849	67.588	66.099
38	15.138	15.835	14.388	104	41.386	42.118	40.636	169	67.248	67.985	66.494
39	15.535	16.234	14.772	105	41.785	42.516	41.030	170	67.645	68.384	66.895
40	15.933	16.633	15.183	106	42.183	42.914	41.433	171	68.043	68.781	67.290
41	16.330	17.031	15.567	107	42.580	43.311	41.826	172	68.440	69.179	67.690
42	16.728	17.430	15.978	108	42.978	43.710	42.228	173	68.839	69.578	68.086
43	17.125	17.829	16.363	109	43.376	44.108	42.621	174	69.236	69.975	68.486
44	17.523	18.228	16.773	110	43.774	44.506	43.024	175	69.634	70.373	68.881
45	17.920	18.626	17.159	111	44.171	44.904	43.420	176	70.033	70.771	69.283
46	18.318	19.024	17.568	112	44.569	45.301	43.819	177	70.430	71.169	69.677
47	18.715	19.423	17.954	113	44.968	45.700	44.213	178	70.828	71.566	70.078
48	19.113	19.821	18.363	114	45.365	46.098	44.615	179	71.225	71.965	70.473
49	19.510	20.220	18.750	115	45.763	46.496	45.009	180	71.624	72.363	70.874
50	19.908	20.619	19.158	116	46.160	46.894	45.410	181	72.021	72.760	71.269
51	20.305	21.016	19.546	117	46.559	47.291	45.804	182	72.419	73.159	71.669
52	20.703	21.415	19.953	118	46.956	47.690	46.206	183	72.818	73.556	72.064
53	21.100	21.814	20.341	119	47.354	48.088	46.600	184	73.215	73.954	72.465
54	21.498	22.211	20.748	120	47.753	48.485	47.003	185	73.613	74.353	72.860
55	21.895	22.610	21.137	121	48.150	48.884	47.396	186	74.010	74.750	73.260
56	22.294	23.009	21.544	122	48.548	49.281	47.798	187	74.409	75.148	73.656
57	22.691	23.406	21.932	123	48.945	49.680	48.192	188	74.806	75.546	74.056
58	23.089	23.805	22.339	124	49.344	50.078	48.594	189	75.204	75.944	74.452
59	23.486	24.204	22.728	125	49.741	50.475	48.987	190	75.603	76.341	74.853
60	23.884	24.601	23.134	126	50.139	50.874	49.389	191	76.000	76.740	75.247
61	24.283	25.000	23.524	127	50.538	51.271	49.783	192	76.398	77.138	75.648
62	24.680	25.398	23.930	128	50.935	51.669	50.185	193	76.795	77.535	76.043
63	25.078	25.796	24.320	129	51.333	52.068	50.579	194	77.194	77.934	76.444
64	25.475	26.195	24.725	130	51.730	52.465	50.980	195	77.591	78.331	76.839
65	25.873	26.593	25.115	131	52.129	52.864	51.375	196	77.989	78.729	77.239
66	26.270	26.991	25.520	132	52.526	53.261	51.776	197	78.388	79.128	77.635
67	26.669	27.389	25.911	133	52.924	53.659	52.170	198	78.785	79.525	78.035
68	27.066	27.788	26.316	134	53.321	54.058	52.571	199	79.183	79.923	78.430
69	27.464	28.185	26.707	135	53.720	54.455	52.966	200	79.581	80.321	78.831
70	27.861	28.584	27.111								

No. 120
1½" Pitch

**Sprocket
Diameter**



Roller Chain Sprocket Diameters

No. of Pitches	Pitch Diameter	Outside Diameter	Caliper Diameter	No. of Pitches	Pitch Diameter	Outside Diameter	Caliper Diameter	No. of Pitches	Pitch Diameter	Outside Diameter	Caliper Diameter
5	2.552	2.964	1.552	71	33.911	34.778	33.028	136	64.941	65.823	64.066
6	3.000	3.498	2.125	72	34.389	35.256	33.514	137	65.418	66.302	64.539
7	3.458	4.014	2.496	73	34.866	35.733	33.983	138	65.897	66.779	65.022
8	3.920	4.521	3.045	74	35.343	36.212	34.468	139	66.374	67.257	65.494
9	4.386	5.022	3.444	75	35.820	36.689	34.938	140	66.851	67.734	65.976
10	4.854	5.517	3.979	76	36.297	37.167	35.422	141	67.328	68.211	66.449
11	5.325	6.009	4.392	77	36.776	37.644	35.892	142	67.806	68.690	66.931
12	5.796	6.498	4.921	78	37.253	38.123	36.378	143	68.283	69.167	67.404
13	6.269	6.986	5.347	79	37.730	38.600	36.847	144	68.760	69.644	67.885
14	6.741	7.472	5.866	80	38.207	39.078	37.332	145	69.237	70.122	68.359
15	7.215	7.956	6.300	81	38.685	39.555	37.802	146	69.716	70.599	68.841
16	7.689	8.441	6.814	82	39.162	40.034	38.287	147	70.193	71.076	69.314
17	8.163	8.924	7.254	83	39.639	40.511	38.757	148	70.670	71.555	69.795
18	8.639	9.407	7.764	84	40.116	40.989	39.241	149	71.148	72.032	70.269
19	9.114	9.890	8.207	85	40.593	41.466	39.712	150	71.625	72.510	70.750
20	9.588	10.371	8.713	86	41.072	41.943	40.197	151	72.102	72.987	71.224
21	10.065	10.853	9.161	87	41.549	42.422	40.667	152	72.579	73.464	71.704
22	10.541	11.333	9.666	88	42.026	42.899	41.151	153	73.058	73.943	72.178
23	11.016	11.814	10.115	89	42.503	43.377	41.622	154	73.535	74.420	72.660
24	11.492	12.294	10.617	90	42.981	43.854	42.106	155	74.012	74.897	73.133
25	11.969	12.774	11.070	91	43.458	44.333	42.576	156	74.490	75.375	73.615
26	12.444	13.254	11.569	92	43.935	44.810	43.060	157	74.967	75.852	74.088
27	12.921	13.734	12.024	93	44.412	45.288	43.531	158	75.444	76.329	74.569
28	13.397	14.213	12.522	94	44.891	45.765	44.016	159	75.923	76.808	75.043
29	13.874	14.693	12.978	95	45.368	46.242	44.48	160	76.400	77.285	75.525
30	14.351	15.171	13.476	96	45.845	46.721	44.970	161	76.877	77.762	75.998
31	14.826	15.651	13.933	97	46.323	47.198	45.441	162	77.354	78.240	76.479
32	15.303	16.130	14.428	98	46.800	47.676	45.925	163	77.832	78.717	76.953
33	15.780	16.610	14.887	99	47.277	48.153	46.396	164	78.309	79.194	77.434
34	16.257	17.088	15.382	100	47.754	48.632	46.879	165	78.786	79.673	77.908
35	16.734	17.567	15.842	101	48.231	49.109	47.351	166	79.265	80.150	78.390
36	17.211	18.045	16.336	102	48.710	49.586	47.835	167	79.742	80.628	78.863
37	17.688	18.524	16.797	103	49.187	50.064	48.306	168	80.219	81.105	79.344
38	18.165	19.002	17.290	104	49.664	50.541	48.789	169	80.697	81.582	79.818
39	18.642	19.481	17.751	105	50.142	51.020	49.261	170	81.174	82.061	80.299
40	19.119	19.959	18.244	106	50.619	51.497	49.744	171	81.651	82.538	80.773
41	19.596	20.438	18.706	107	51.096	51.974	50.216	172	82.128	83.015	81.253
42	20.073	20.916	19.198	108	51.573	52.452	50.698	173	82.607	83.493	81.728
43	20.550	21.395	19.661	109	52.052	52.929	51.171	174	83.084	83.970	82.209
44	21.027	21.873	20.152	110	52.529	53.408	51.654	175	83.561	84.447	82.683
45	21.504	22.352	20.615	111	53.006	53.885	52.125	176	84.039	84.926	83.164
46	21.981	22.829	21.106	112	53.483	54.362	52.608	177	84.501	85.403	83.637
47	22.458	23.307	21.570	113	53.961	54.840	53.080	178	84.993	85.880	84.118
48	22.935	23.786	22.060	114	54.438	55.317	53.563	179	85.470	86.358	84.592
49	23.412	24.264	22.525	115	54.915	55.796	54.035	180	85.949	86.835	85.074
50	23.889	24.743	23.014	116	55.392	56.273	54.517	181	86.426	87.312	85.547
51	24.366	25.220	23.480	117	55.871	56.750	54.990	182	86.903	87.791	86.028
52	24.843	25.698	23.968	118	56.348	57.228	55.473	183	87.381	88.268	86.502
53	25.320	26.177	24.434	119	56.825	57.705	55.945	184	87.858	88.745	86.983
54	25.797	26.654	24.922	120	57.303	58.182	56.428	185	88.335	89.223	87.457
55	26.274	27.132	25.389	121	57.780	58.661	56.900	186	88.812	89.700	87.937
56	26.753	27.611	25.878	122	58.257	59.138	57.382	187	89.291	90.177	88.412
57	27.230	28.088	26.344	123	58.734	59.616	57.855	188	89.768	90.656	88.893
58	27.707	28.566	26.832	124	59.213	60.093	58.338	189	90.245	91.133	89.367
59	28.184	29.045	27.299	125	59.690	60.570	58.810	190	90.723	91.610	89.848
60	28.661	29.522	27.786	126	60.167	61.049	59.292	191	91.200	92.088	90.322
61	29.139	30.000	28.254	127	60.645	61.526	59.765	192	91.677	92.565	90.802
62	29.616	30.477	28.741	128	61.122	62.003	60.247	193	92.154	93.042	91.277
63	30.093	30.956	29.208	129	61.599	62.481	60.720	194	92.633	93.521	91.758
64	30.570	31.434	29.695	130	62.076	62.958	61.201	195	93.110	93.998	92.232
65	31.047	31.911	30.163	131	62.555	63.437	61.674	196	93.587	94.475	92.712
66	31.524	32.390	30.649	132	63.032	63.914	62.157	197	94.065	94.953	93.187
67	32.003	32.867	31.118	133	63.509	64.391	62.629	198	94.542	95.430	93.667
68	32.480	33.345	31.605	134	63.986	64.869	63.111	199	95.019	95.907	94.141
69	32.957	33.822	32.073	135	64.464	65.346	63.584	200	95.498	96.386	94.623
70	33.434	34.301	32.559								



Sprocket Diameter

No. 140 1³/₄" Pitch

Roller Chain Sprocket Diameters

No. of Pitches	Pitch Diameter	Outside Diameter	Caliper Diameter	No. of Pitches	Pitch Diameter	Outside Diameter	Caliper Diameter	No. of Pitches	Pitch Diameter	Outside Diameter	Caliper Diameter
5	2.977	3.458	1.832	71	39.562	40.574	38.553	136	75.765	76.794	74.765
6	3.500	4.081	2.500	72	40.121	41.132	39.121	137	76.321	77.352	75.316
7	4.034	4.683	2.932	73	40.677	41.689	39.667	138	76.879	77.908	75.879
8	4.573	5.275	3.573	74	41.234	42.247	40.234	139	77.436	78.467	76.431
9	5.117	5.859	4.039	75	41.790	42.803	40.781	140	78.008	79.023	77.008
10	5.663	6.437	4.663	76	42.347	43.362	41.347	141	78.549	79.580	77.545
11	6.213	7.011	5.148	77	42.905	43.918	41.895	142	79.107	80.138	78.107
12	6.762	7.581	5.762	78	43.461	44.476	42.461	143	79.664	80.694	78.484
13	7.313	8.150	6.259	79	44.018	45.033	43.009	144	80.220	81.251	79.220
14	7.865	8.717	6.865	80	44.574	45.591	43.574	145	80.777	81.809	79.773
15	8.418	9.282	7.371	81	45.133	46.148	44.123	146	81.335	82.366	80.335
16	8.971	9.847	7.971	82	45.689	46.706	44.689	147	81.891	82.922	80.887
17	9.524	10.411	8.483	83	46.246	47.262	45.237	148	82.448	83.480	81.448
18	10.078	10.974	9.078	84	46.802	47.821	45.802	149	83.006	84.037	82.000
19	10.633	11.538	9.596	85	47.359	48.377	46.351	150	83.563	84.595	82.563
20	11.186	12.100	10.186	86	47.917	48.934	46.917	151	84.119	85.152	83.115
21	11.743	12.661	10.709	87	48.473	49.492	47.465	152	84.676	85.708	83.676
22	12.297	13.221	11.297	88	49.030	50.048	48.030	153	85.234	86.266	84.229
23	12.852	13.783	11.822	89	49.586	50.607	48.579	154	85.790	86.823	84.790
24	13.407	14.343	12.407	90	50.145	51.163	49.145	155	86.347	87.379	85.343
25	13.963	14.903	12.935	91	50.701	51.721	49.693	156	86.905	87.938	85.905
26	14.518	15.463	13.518	92	51.258	52.278	50.258	157	87.462	88.494	86.457
27	15.075	16.023	14.049	93	51.814	52.836	50.807	158	88.018	89.051	87.018
28	15.629	16.581	14.629	94	52.372	53.393	51.372	159	88.576	89.609	87.571
29	16.186	17.141	15.162	95	52.929	53.949	51.921	160	89.133	90.165	88.133
30	16.742	17.700	15.742	96	53.485	54.507	52.485	161	89.689	90.722	88.685
31	17.297	18.260	16.276	97	54.044	55.064	53.035	162	90.246	91.280	89.246
32	17.854	18.818	16.854	98	54.600	55.622	53.600	163	90.804	91.837	89.799
33	18.410	19.378	17.389	99	55.157	56.179	54.150	164	91.361	92.393	90.361
34	18.967	19.936	17.967	100	55.713	56.737	54.713	165	91.917	92.951	90.913
35	19.523	20.494	18.503	101	56.270	57.293	55.264	166	92.475	93.508	91.475
36	20.080	21.053	19.080	102	56.828	57.850	55.828	167	93.032	94.066	92.027
37	20.636	21.611	19.617	103	57.384	58.408	56.378	168	93.588	94.623	92.588
38	21.193	22.169	20.193	104	57.941	58.965	56.941	169	94.147	95.179	93.141
39	21.749	22.727	20.730	105	58.499	59.523	57.492	170	94.703	95.737	93.703
40	22.306	23.286	21.306	106	59.056	60.079	58.056	171	95.260	96.294	94.255
41	22.862	23.844	21.844	107	59.612	60.636	58.606	172	95.816	96.850	94.816
42	23.419	24.402	22.419	108	60.169	61.194	59.169	173	96.374	97.409	95.370
43	23.975	24.960	22.958	109	60.727	61.751	59.720	174	96.931	97.965	95.931
44	24.532	25.519	23.532	110	61.283	62.309	60.283	175	97.487	98.522	96.484
45	25.088	26.077	24.072	111	61.840	62.865	60.834	176	98.046	99.080	97.046
46	25.645	26.633	24.645	112	62.396	63.422	61.396	177	98.602	99.636	97.598
47	26.201	27.192	25.186	113	62.955	63.980	61.948	178	99.159	100.193	98.159
48	26.758	27.750	25.758	114	63.511	64.537	62.511	179	99.715	100.751	98.712
49	27.314	28.308	26.300	115	64.068	65.095	63.062	180	100.273	101.308	99.273
50	27.871	28.866	26.871	116	64.624	65.651	63.624	181	100.830	101.864	99.826
51	28.427	29.423	27.414	117	65.182	66.208	64.176	182	101.386	102.422	100.386
52	28.984	29.981	27.984	118	65.739	66.766	64.739	183	101.945	102.979	100.940
53	29.540	30.539	28.528	119	66.295	67.323	65.290	184	102.501	103.535	101.501
54	30.097	31.096	29.097	120	66.854	67.879	65.854	185	103.058	104.094	102.054
55	30.653	31.654	29.641	121	67.410	68.437	66.404	186	103.614	104.650	102.614
56	31.211	32.212	30.211	122	67.967	68.994	66.967	187	104.172	105.207	103.168
57	31.768	32.769	30.755	123	68.523	69.552	67.518	188	104.729	105.765	103.729
58	32.324	33.327	31.324	124	69.081	70.109	68.081	189	105.285	106.321	104.282
59	32.881	33.885	31.869	125	69.638	70.665	68.632	190	105.844	106.878	104.844
60	33.437	34.442	32.437	126	70.194	71.223	69.194	191	106.400	107.436	105.396
61	33.996	35.000	32.983	127	70.753	71.780	69.746	192	106.957	107.993	105.957
62	34.552	35.557	33.552	128	71.309	72.336	70.309	193	107.513	108.549	106.510
63	35.109	36.115	34.097	129	71.866	72.895	70.860	194	108.071	109.107	107.071
64	35.665	36.673	34.665	130	72.422	73.451	71.422	195	108.628	109.664	107.624
65	36.222	37.230	35.211	131	72.980	74.009	71.974	196	109.184	110.220	108.184
66	36.778	37.788	35.778	132	73.537	74.566	72.537	197	109.743	110.779	108.738
67	37.336	38.344	36.325	133	74.093	75.122	73.088	198	110.299	111.335	109.299
68	37.893	38.903	36.893	134	74.650	75.681	73.650	199	110.856	111.892	109.853
69	38.449	39.459	37.439	135	75.208	76.237	74.202	200	111.414	112.450	110.414
70	39.006	40.017	38.006								

No. 160

2" Pitch

Sprocket Diameter



Roller Chain Sprocket Diameters

No. of Pitches	Pitch Diameter	Outside Diameter	Caliper Diameter	No. of Pitches	Pitch Diameter	Outside Diameter	Caliper Diameter	No. of Pitches	Pitch Diameter	Outside Diameter	Caliper Diameter
5	3.402	3.952	2.111	71	45.214	46.370	44.079	136	86.588	87.764	85.463
6	4.000	4.664	2.875	72	45.852	47.008	44.727	137	87.224	88.402	86.094
7	4.610	5.352	3.369	73	46.488	47.644	45.352	138	87.862	89.038	86.737
8	5.226	6.028	4.101	74	47.124	48.282	45.999	139	88.498	89.676	87.367
9	5.848	6.696	4.635	75	47.760	48.918	46.625	140	89.134	90.312	88.009
10	6.472	7.356	5.347	76	48.396	49.556	47.271	141	89.770	90.948	88.640
11	7.100	8.012	5.902	77	49.034	50.192	47.898	142	90.408	91.586	89.283
12	7.728	8.664	6.603	78	49.670	50.830	48.545	143	91.044	92.222	89.913
13	8.358	9.314	7.171	79	50.306	51.466	49.171	144	91.680	92.858	90.555
14	8.988	9.962	7.863	80	50.942	52.104	49.817	145	92.316	93.496	91.187
15	9.620	10.608	8.442	81	51.580	52.740	50.444	146	92.945	94.132	91.829
16	10.252	11.254	9.127	82	52.216	53.378	51.091	147	93.590	94.768	92.460
17	10.844	11.898	9.713	83	52.852	54.014	51.718	148	94.226	95.406	93.101
18	11.518	12.542	10.393	84	53.488	54.652	52.363	149	94.864	96.042	93.733
19	12.152	13.186	10.985	85	54.124	55.288	52.991	150	95.500	96.680	94.375
20	12.784	13.828	11.659	86	54.762	55.924	53.637	151	96.136	97.316	95.006
21	13.420	14.470	12.256	87	55.398	56.562	54.264	152	96.772	97.952	95.647
22	14.054	15.110	12.929	88	56.034	57.198	54.909	153	97.410	98.590	96.280
23	14.688	15.752	13.529	89	56.670	57.836	55.537	154	98.046	99.226	96.921
24	15.322	16.392	14.197	90	57.308	58.472	56.183	155	98.682	99.862	97.553
25	15.958	17.032	14.801	91	57.944	59.110	56.810	156	99.320	100.500	98.195
26	16.592	17.672	15.467	92	58.580	59.746	57.455	157	99.956	101.136	98.826
27	17.228	18.312	16.073	93	59.216	60.384	58.083	158	100.592	101.772	99.467
28	17.862	18.950	16.737	94	59.854	61.020	58.729	159	101.230	102.410	100.099
29	18.498	19.590	17.346	95	60.490	61.656	59.357	160	101.866	103.046	100.741
30	19.134	20.228	18.009	96	61.126	62.294	60.001	161	102.502	103.682	101.372
31	19.768	20.868	18.619	97	61.764	62.930	60.630	162	103.138	104.320	102.013
32	20.404	21.506	19.279	98	62.400	63.568	61.275	163	103.776	104.956	102.646
33	21.040	22.146	19.891	99	63.036	64.204	61.903	164	104.412	105.592	103.287
34	21.676	22.784	20.551	100	63.672	64.842	62.547	165	105.048	106.230	103.919
35	22.312	23.422	21.164	101	64.308	65.478	63.176	166	105.686	106.866	104.561
36	22.948	24.060	21.823	102	64.946	66.114	63.821	167	106.322	107.504	105.192
37	23.584	24.698	22.437	103	65.582	66.752	64.449	168	106.958	108.140	105.833
38	24.220	25.336	23.095	104	66.218	67.388	65.093	169	107.596	108.776	106.465
39	24.856	25.974	23.710	105	66.856	68.026	65.723	170	108.232	109.414	107.107
40	25.492	26.612	24.367	106	67.492	68.662	66.367	171	108.868	110.050	107.738
41	26.128	27.250	24.983	107	68.128	69.298	66.996	172	109.504	110.686	108.379
42	26.764	27.888	25.639	108	68.764	69.936	67.639	173	110.142	111.324	109.012
43	27.400	28.526	26.256	109	69.402	70.572	68.269	174	110.778	111.960	109.653
44	28.036	29.164	26.911	110	70.038	70.210	68.913	175	111.414	112.596	110.285
45	28.672	29.802	27.529	111	70.674	71.846	69.542	176	112.052	113.234	110.927
46	29.308	30.438	28.183	112	71.310	72.482	70.185	177	112.688	113.870	111.558
47	29.944	31.076	28.802	113	71.948	73.120	70.815	178	113.324	114.506	112.199
48	30.580	31.714	29.455	114	72.584	73.756	71.459	179	113.960	115.144	112.831
49	31.216	32.352	30.075	115	73.220	74.394	72.089	180	114.598	115.780	113.473
50	31.852	32.990	30.727	116	73.856	75.030	72.731	181	115.234	116.416	114.105
51	32.488	33.626	31.348	117	74.494	75.666	73.362	182	115.870	117.054	114.745
52	33.124	34.264	31.999	118	75.130	76.304	74.005	183	116.508	117.690	115.388
53	33.760	34.902	32.621	119	75.766	76.940	74.645	184	117.144	118.326	116.019
54	34.396	35.538	33.271	120	76.404	77.576	75.279	185	117.780	118.964	116.651
55	35.032	36.176	33.894	121	77.040	78.214	75.908	186	118.416	119.600	117.291
56	35.670	36.814	34.545	122	77.676	78.850	76.551	187	119.054	120.236	117.924
57	36.306	37.450	35.167	123	78.312	79.488	77.181	188	119.690	120.874	118.565
58	36.942	38.088	35.817	124	78.950	80.124	77.825	189	120.326	121.510	119.197
59	37.578	38.726	36.440	125	79.586	80.760	78.455	190	120.964	122.146	119.839
60	38.214	39.362	37.089	126	80.222	81.398	79.097	191	121.600	122.784	120.471
61	38.852	40.000	37.713	127	80.860	82.034	79.728	192	122.236	123.420	121.111
62	39.488	40.636	38.363	128	81.496	82.670	80.371	193	122.872	124.056	121.744
63	40.124	41.274	38.986	129	82.132	83.308	81.001	194	123.510	124.694	122.385
64	40.760	41.912	39.635	130	82.768	83.944	81.643	195	124.146	125.330	123.017
65	41.396	42.548	40.259	131	83.406	84.582	82.274	196	124.781	125.966	123.656
66	42.032	43.186	40.907	132	84.042	85.218	82.917	197	125.420	126.604	124.290
67	42.670	43.822	41.532	133	84.678	85.854	83.547	198	126.056	127.240	124.931
68	43.306	44.460	42.181	134	85.314	86.492	84.189	199	126.692	127.876	125.564
69	43.942	45.096	42.806	135	85.952	87.128	84.820	200	127.330	128.514	126.205
70	44.578	45.734	43.453								



Sprocket Diameter

No. 180 2¼" Pitch

Roller Chain Sprocket Diameters

No. of Pitches	Pitch Diameter	Outside Diameter	Caliper Diameter	No. of Pitches	Pitch Diameter	Outside Diameter	Caliper Diameter	No. of Pitches	Pitch Diameter	Outside Diameter	Caliper Diameter
5	3.828	4.446	2.234	71	50.866	52.166	49.448	136	97.412	98.735	96.006
6	4.500	5.247	3.094	72	51.583	52.884	50.177	137	98.128	99.452	96.715
7	5.186	6.021	3.650	73	52.299	53.600	50.880	138	98.844	100.106	97.438
8	5.879	6.782	4.473	74	53.015	54.317	51.609	139	99.560	100.886	98.148
9	6.579	7.533	5.073	75	53.730	55.033	52.313	140	100.276	101.601	98.870
10	7.281	8.276	5.875	76	54.446	55.751	53.040	141	100.992	102.317	99.580
11	7.986	9.014	6.499	77	55.162	56.466	53.745	142	101.708	103.034	100.302
12	8.693	9.747	7.287	78	55.879	57.184	54.473	143	102.425	103.750	101.012
13	9.402	10.478	7.927	79	56.594	57.899	55.177	144	103.140	104.465	101.734
14	10.112	11.207	8.706	80	57.310	58.617	55.904	145	103.857	105.183	102.445
15	10.822	11.934	9.357	81	58.027	59.333	56.610	146	104.573	105.899	103.167
16	11.533	12.661	10.127	82	58.743	60.055	57.337	147	105.289	106.614	103.877
17	12.245	13.385	10.787	83	59.459	60.766	58.042	148	106.005	108.332	104.599
18	12.957	14.110	11.551	84	60.175	61.484	58.769	149	106.721	108.047	105.309
19	13.670	14.834	12.217	85	60.891	62.199	59.474	150	107.438	108.765	106.032
20	14.383	15.557	12.977	86	61.607	62.915	60.201	151	108.154	109.481	106.742
21	15.096	16.279	13.648	87	62.323	63.632	60.907	152	108.870	110.196	107.464
22	15.810	16.999	14.404	88	63.039	63.348	61.633	153	109.586	110.914	108.174
23	16.524	17.721	15.079	89	63.755	65.066	62.339	154	110.302	111.629	108.896
24	17.238	18.441	15.832	90	64.471	65.781	63.065	155	111.018	112.345	109.607
25	17.952	19.161	16.511	91	65.187	66.499	63.771	156	111.734	113.063	110.328
26	18.666	19.881	17.260	92	65.903	67.214	64.497	157	112.451	113.778	111.039
27	19.381	20.601	17.942	93	66.619	67.932	65.203	158	113.167	114.494	111.761
28	20.096	21.319	18.690	94	67.335	68.648	65.929	159	113.883	115.211	112.471
29	20.810	22.039	19.374	95	68.051	69.363	66.636	160	114.599	115.927	113.193
30	21.525	22.757	20.119	96	68.767	70.081	67.361	161	115.315	116.642	113.904
31	22.240	23.477	20.806	97	69.483	70.796	68.068	162	116.031	117.360	114.625
32	22.955	24.194	21.549	98	70.199	71.514	68.793	163	116.747	118.076	115.336
33	23.670	24.914	22.237	99	70.916	72.230	69.500	164	117.464	118.791	116.058
34	24.385	25.632	22.979	100	71.631	72.947	70.225	165	118.180	119.509	116.768
35	25.101	26.350	23.669	101	72.348	73.663	70.933	166	118.896	120.224	117.490
36	25.816	27.068	24.410	102	73.064	74.378	71.658	167	119.612	120.942	118.201
37	26.531	27.785	25.101	103	73.780	75.096	72.365	168	120.328	121.658	118.922
38	27.246	28.503	25.840	104	74.496	75.812	73.090	169	121.044	122.373	119.633
39	27.962	29.221	26.533	105	75.212	76.529	73.798	170	121.760	123.091	120.354
40	28.677	29.939	27.271	106	75.928	77.245	74.522	171	122.477	123.806	121.065
41	29.393	30.656	27.965	107	76.644	77.960	75.230	172	123.193	124.522	121.787
42	30.108	31.374	28.702	108	77.360	78.678	75.954	173	123.909	125.240	122.498
43	30.824	32.092	29.397	109	79.073	79.394	76.662	174	124.625	125.955	123.219
44	31.539	32.810	30.133	110	78.792	80.111	77.386	175	125.341	126.671	123.930
45	32.255	33.527	30.830	111	79.508	80.827	78.095	176	126.057	127.388	124.651
46	32.971	34.243	31.565	112	80.225	81.542	78.819	177	126.774	128.104	125.363
47	33.686	34.961	32.262	113	80.931	82.260	79.527	178	127.490	128.819	126.084
48	34.402	35.678	32.996	114	81.657	82.976	80.251	179	128.206	129.537	126.795
49	35.118	36.396	33.694	115	82.373	83.693	80.959	180	128.922	130.253	127.516
50	35.834	37.114	34.428	116	83.089	84.409	81.683	181	129.638	130.968	128.227
51	36.549	37.829	35.126	117	83.805	85.124	82.392	182	130.354	131.686	128.948
52	37.265	38.547	35.859	118	84.521	85.842	83.115	183	131.071	132.401	129.660
53	37.981	39.265	36.558	119	85.237	86.558	83.824	184	131.787	133.117	130.381
54	38.696	39.980	37.290	120	85.953	87.273	84.547	185	132.503	133.835	131.092
55	39.412	40.698	37.990	121	86.670	87.991	85.256	186	133.219	134.550	131.813
56	40.128	41.416	38.722	122	87.386	88.706	85.980	187	133.935	135.266	132.524
57	40.844	42.131	39.422	123	88.102	89.424	86.689	188	134.651	135.983	133.245
58	41.560	42.849	40.154	124	88.818	90.140	87.412	189	135.367	136.699	133.957
59	42.276	43.567	40.855	125	89.534	90.855	88.121	190	136.084	137.414	134.678
60	42.991	44.282	41.585	126	90.250	91.573	88.844	191	136.800	138.132	135.389
61	43.707	45.000	42.287	127	90.966	92.288	89.553	192	137.516	138.848	136.110
62	44.423	45.716	43.017	128	91.682	93.004	90.276	193	138.232	139.563	136.822
63	45.139	46.433	43.719	129	92.399	93.722	90.986	194	138.948	140.281	137.542
64	45.855	47.151	44.449	130	93.115	94.437	91.709	195	139.664	140.996	138.254
65	46.571	47.867	45.151	131	93.831	95.155	92.418	196	140.381	141.712	138.975
66	47.287	48.584	45.881	132	94.547	95.870	93.141	197	141.097	142.430	139.686
67	48.003	49.300	46.584	133	95.263	96.586	93.850	198	141.813	143.145	140.407
68	48.719	50.018	47.313	134	95.979	97.304	94.573	199	142.529	143.861	141.119
69	49.435	50.733	48.016	135	96.695	98.019	95.283	200	143.245	144.578	141.839
70	50.151	51.451	48.745								

No. 200

2 1/2" Pitch

Sprocket Diameter



Roller Chain Sprocket Diameters

No. of Pitches	Pitch Diameter	Outside Diameter	Caliper Diameter	No. of Pitches	Pitch Diameter	Outside Diameter	Caliper Diameter	No. of Pitches	Pitch Diameter	Outside Diameter	Caliper Diameter
5	4.253	4.940	2.482	71	56.518	57.962	54.942	136	108.235	109.705	106.672
6	5.000	5.830	3.438	72	57.315	58.760	55.752	137	109.030	110.502	107.461
7	5.760	6.690	4.055	73	58.110	59.555	56.533	138	109.827	111.297	108.264
8	6.533	7.535	4.970	74	58.905	60.352	57.342	139	110.622	112.095	109.052
9	7.310	8.370	5.636	75	59.700	61.147	58.125	140	111.418	112.890	109.855
10	8.090	9.195	6.527	76	60.495	61.945	58.932	141	112.212	113.685	110.644
11	8.875	10.015	7.220	77	61.292	62.740	59.716	142	113.010	114.482	111.447
12	9.660	10.830	8.097	78	62.087	63.537	60.524	143	113.805	115.277	112.235
13	10.447	11.642	8.807	79	62.882	64.332	61.307	144	114.600	116.072	113.037
14	11.235	12.452	9.672	80	63.678	65.130	62.115	145	115.395	116.870	113.827
15	12.025	13.260	10.396	81	64.475	65.925	62.899	146	116.192	117.665	114.629
16	12.815	14.068	11.252	82	65.270	66.722	63.707	147	116.988	118.460	115.418
17	13.605	14.872	11.985	83	66.065	67.517	64.490	148	117.783	119.257	116.220
18	14.397	15.678	12.834	84	66.860	68.315	65.297	149	118.580	120.052	117.010
19	15.190	16.478	13.574	85	67.655	69.110	66.082	150	119.375	120.850	117.812
20	15.980	17.285	14.417	86	68.452	69.905	66.889	151	120.170	121.645	118.601
21	16.775	18.088	15.164	87	69.247	70.702	67.673	152	120.965	122.440	119.402
22	17.567	18.888	16.004	88	70.043	71.497	68.480	153	121.762	123.237	120.193
23	18.360	19.690	16.754	89	70.838	72.295	69.265	154	122.558	124.032	120.995
24	19.153	20.490	17.590	90	71.635	73.090	70.072	155	123.354	124.827	121.784
25	19.947	21.290	18.345	91	72.430	73.887	70.856	156	124.150	125.624	122.587
26	20.740	22.090	19.177	92	73.225	74.682	71.662	157	124.945	126.420	123.376
27	21.535	22.890	19.935	93	74.020	75.480	72.448	158	125.740	127.215	124.177
28	22.327	23.688	20.764	94	74.817	76.275	73.254	159	126.537	128.012	124.967
29	23.123	24.488	21.526	95	75.612	77.070	74.039	160	127.332	128.807	125.769
30	23.917	25.285	22.354	96	76.408	77.867	74.845	161	128.127	129.602	126.559
31	24.710	26.085	23.117	97	77.205	78.662	75.631	162	128.923	130.400	127.360
32	25.505	26.882	23.942	98	78.000	79.460	76.437	163	129.720	131.195	128.150
33	26.300	27.682	24.708	99	78.795	80.255	77.222	164	130.515	131.990	128.952
34	27.095	28.480	25.532	100	79.590	81.052	78.027	165	131.310	132.787	129.742
35	27.890	29.280	26.300	101	80.385	81.847	78.814	166	132.107	133.582	130.544
36	28.685	30.075	27.122	102	81.182	82.642	79.619	167	132.903	134.380	131.333
37	29.480	30.872	27.890	103	81.977	83.440	80.405	168	133.697	135.175	132.134
38	30.275	31.670	28.712	104	82.773	84.235	81.210	169	134.495	135.970	132.925
39	31.070	32.468	29.481	105	83.570	85.032	81.997	170	135.290	136.767	133.727
40	31.865	33.265	30.302	106	84.365	85.827	82.802	171	136.085	137.562	134.516
41	32.660	34.062	31.072	107	85.160	86.622	83.588	172	136.880	138.357	135.317
42	33.455	34.860	31.892	108	85.955	87.420	84.392	173	137.677	139.155	136.108
43	34.250	35.658	32.663	109	86.753	88.215	85.180	174	138.472	139.950	136.909
44	35.045	36.455	33.482	110	87.547	89.012	85.984	175	139.268	140.745	137.700
45	35.840	37.252	34.254	111	88.342	89.808	86.771	176	140.065	141.542	138.502
46	36.635	38.047	35.072	112	89.137	90.603	87.574	177	140.860	142.337	139.291
47	37.430	38.845	35.846	113	89.935	91.400	88.363	178	141.655	143.132	140.092
48	38.225	39.642	36.662	114	90.730	92.195	89.167	179	142.450	143.930	140.883
49	39.020	40.440	37.437	115	91.525	92.992	89.954	180	143.247	144.725	141.684
50	39.815	41.238	38.252	116	92.320	93.787	90.757	181	144.042	145.520	142.474
51	40.610	42.032	39.028	117	93.117	94.582	91.546	182	144.838	146.318	143.275
52	41.405	42.830	39.842	118	93.912	95.380	92.349	183	145.635	147.113	144.066
53	42.200	43.627	40.619	119	94.707	96.175	93.137	184	146.430	147.908	144.867
54	42.995	44.422	41.432	120	95.505	96.970	93.942	185	147.225	148.705	145.657
55	43.790	45.220	42.211	121	96.300	97.767	94.729	186	148.020	149.500	146.457
56	44.587	46.018	43.024	122	97.095	98.562	95.532	187	148.817	150.295	147.249
57	45.383	46.812	43.802	123	97.890	99.360	96.320	188	149.612	151.093	148.049
58	46.177	47.610	44.614	124	98.687	100.155	97.124	189	150.408	151.888	148.840
59	46.973	48.408	45.393	125	99.482	100.950	97.912	190	151.205	152.683	149.642
60	47.768	49.202	46.205	126	100.278	101.747	98.715	191	152.000	153.480	150.432
61	48.565	50.000	46.964	127	101.075	102.542	99.503	192	152.795	154.275	151.232
62	49.360	50.795	47.797	128	101.870	103.337	100.307	193	153.590	155.070	152.023
63	50.155	51.593	48.576	129	102.665	104.135	101.095	194	154.387	155.868	152.824
64	50.950	52.390	49.387	130	103.460	104.930	101.897	195	155.183	156.663	153.615
65	51.745	53.185	50.167	131	104.257	105.727	102.686	196	155.977	157.458	154.414
66	52.540	53.982	50.977	132	105.052	106.522	103.489	197	156.775	158.255	155.206
67	53.337	54.777	51.759	133	105.847	107.317	104.278	198	157.570	159.050	156.007
68	54.132	55.575	52.569	134	106.643	108.115	105.080	199	158.365	159.845	156.798
69	54.927	56.370	53.350	135	107.440	108.910	105.869	200	159.162	160.643	157.599
70	55.723	57.167	54.160								



Sprocket Diameter

No. 240 3" Pitch

Roller Chain Sprocket Diameters

No. of Pitches	Pitch Diameter	Outside Diameter	Caliper Diameter	No. of Pitches	Pitch Diameter	Outside Diameter	Caliper Diameter	No. of Pitches	Pitch Diameter	Outside Diameter	Caliper Diameter
6	6.000	7.00	4.125	45	43.007	44.70	41.105	83	79.278	81.02	77.388
7	6.914	8.03	4.866	46	43.961	45.66	42.086	84	80.233	81.98	78.358
8	7.839	9.04	5.964	47	44.915	46.61	43.013	85	81.188	82.93	79.298
9	8.771	10.04	6.764	48	45.869	47.57	43.994	86	82.142	83.89	80.267
10	9.708	11.03	7.833	49	46.824	48.53	44.925	87	83.097	84.84	81.207
11	10.649	12.02	8.666	50	47.778	49.49	45.903	88	84.052	85.80	82.177
12	11.591	13.00	9.716	51	48.732	50.44	46.833	89	85.006	86.75	83.116
13	12.536	13.97	10.568	52	49.687	51.40	47.812	90	85.961	87.71	84.086
14	13.482	14.94	11.607	53	50.641	52.35	48.744	91	86.916	88.67	85.026
15	14.429	15.91	12.473	54	51.595	53.31	49.720	92	87.871	89.62	85.996
16	15.377	16.88	13.502	55	52.550	54.26	50.654	93	88.825	90.58	86.938
17	16.327	17.85	14.383	56	53.504	55.22	51.629	94	89.780	91.53	87.905
18	17.276	18.81	15.401	57	54.458	56.18	52.562	95	90.735	92.48	88.848
19	18.227	19.78	16.289	58	55.413	57.13	53.538	96	91.690	93.44	89.815
20	19.177	20.74	17.302	59	56.368	58.09	54.473	97	92.645	94.40	90.758
21	20.129	21.71	18.197	60	57.322	59.04	55.447	98	93.599	95.35	91.724
22	21.080	22.67	19.205	61	58.277	60.00	56.384	99	94.554	96.31	92.667
23	22.032	23.63	20.106	62	59.231	60.95	57.356	100	95.507	97.26	93.634
24	22.984	24.59	21.109	63	60.185	61.91	58.292	101	96.463	98.22	94.676
25	23.936	25.55	22.013	64	61.140	62.87	59.265	102	97.418	99.17	95.543
26	24.889	26.51	23.014	65	62.095	63.82	60.202	103	98.373	100.13	96.486
27	25.841	27.47	23.921	66	63.049	64.78	61.174	104	99.328	101.08	97.453
28	26.794	28.43	24.919	67	64.004	65.73	62.111	105	100.283	102.04	98.396
29	27.747	29.39	25.833	68	64.958	66.69	63.083	106	101.237	102.99	99.362
30	28.700	30.34	26.825	69	65.913	67.64	64.023	107	102.192	103.95	100.305
31	29.654	31.30	27.740	70	66.868	68.60	64.993	108	103.147	104.90	101.272
32	30.607	32.26	28.732	71	67.822	69.56	65.932	109	104.102	105.86	102.215
33	31.560	33.22	29.649	72	68.777	70.51	66.902	110	105.056	106.82	103.181
34	32.514	34.18	30.639	73	69.731	71.45	67.841	111	106.011	107.77	104.124
35	33.467	35.13	31.559	74	70.686	72.42	68.811	112	106.966	108.72	105.091
36	34.421	36.09	32.546	75	71.641	73.38	69.751	113	107.922	109.68	106.035
37	35.375	37.05	33.467	76	72.595	74.33	70.720	114	108.876	110.63	107.001
38	36.329	38.00	34.454	77	73.550	75.29	71.660	115	109.830	111.59	107.943
39	37.283	38.96	35.378	78	74.505	76.25	72.630	116	110.786	112.55	108.911
40	38.237	39.92	36.362	79	75.459	77.20	73.569	117	111.740	113.50	109.820
41	39.191	40.88	37.286	80	76.414	78.16	74.539	118	112.695	114.46	110.810
42	40.145	41.83	38.270	81	77.369	79.11	75.479	119	113.650	115.41	111.750
43	41.099	42.79	39.197	82	78.323	80.07	76.448	120	114.605	116.36	112.730
44	42.053	43.75	40.178								